

Features

- High Efficiency (Up to 91%)
- Constant Current Output
- Extreme Cold Temperature Operation Down to -55°C
- 0-10V Dimming Control
- Lightning Protection
- All-Around Protection: OVP, SCP, OTP
- IP67
- SELV Output
- 5 Years Warranty



CE CB K

Description

The EUC-075S070DVY(SVY) series is a 75W, constant-current LED driver for extreme cold that operates from 90-305 Vac input with excellent power factor. It is created for many lighting applications including low bay, tunnel and street, etc. The high efficiency of these drivers and compact metal case enables them to run cooler, significantly improving reliability and extending product life. To ensure trouble-free operation, protection is provided against over voltage, short circuit, and over temperature.

Models

Output Current	Input Voltage Range(1)	Output Voltage Range	Max. Output Power	Typical Efficiency (2)	Power Factor		Model Number
					120Vac	220Vac	
700 mA	90~305 Vac	54~108Vdc	75 W	91%	0.99	0.96	EUC-075S070DVY(SVY) ⁽³⁾

- Notes:** (1) Certified input voltage range: 100-240Vac
 (2) Measured at 100% load and 220 Vac input
 (3) SELV output

Input Specifications

Parameter	Min.	Typ.	Max.	Notes
Input Voltage	90 Vac	-	305 Vac	
Input Frequency	47 Hz	-	63 Hz	
Leakage Current	-	-	0.70 mA	IEC60598-1; 240Vac/ 60Hz
Input AC Current	-	-	0.9 A	Measured at 100% load and 100 Vac input.
	-	-	0.42 A	Measured at 100% load and 220 Vac input.
Inrush Current(I ² t)	-	-	1.70 A ² s	At 220Vac input, 25°C cold start, duration=960 us, 10%Ipk-10%Ipk. See Inrush Current Waveform for the details.
PF	0.9	-	-	At 100-277Vac,50-60Hz,65%-100%Load (49-75W)
THD	-	-	20%	

Output Specifications

Parameter	Min.	Typ.	Max.	Notes
Output Current Tolerance	-5%Io	-	5%Io	At 100% load condition
Output Current Ripple (pk-pk)	-	5%Io	10%Io	At 100% load condition
Startup Overshoot Current	-	-	10%Io	At 100% load condition.
No Load Output Voltage	-	-	120 V	
Line Regulation	-	-	±0.5%	Measured at 100% load
Load Regulation	-	-	±1.5%	
Turn-on Time	-	2 s	3 s	Measured at 120Vac and 220Vac input, 65%-100% Load.
	-	30 s	40 s	Measured at 120Vac and 220Vac input, 65%-100% Load, -35°C~-10°C.
	-	120 s	150 s	Measured at 120Vac and 220Vac input, 65%-100% Load, -55°C~-35°C.
Temperature Coefficient	-	0.03%/°C	-	Case temperature = 0°C ~Tc max
12V Auxiliary Output Voltage	10.8 V	12 V	13.2 V	
12V Auxiliary Output Source Current	0 mA	-	20 mA	Return terminal is "Dim"

Note: All specifications are typical at 25°C unless otherwise stated.

General Specifications

Parameter	Min.	Typ.	Max.	Notes
Efficiency at 120 Vac input Io = 700 mA	87.0%	89.0%	-	Measured at 100% load and steady-state temperature in 25°C ambient; (Efficiency will be about 2.0% lower if measured immediately after startup.)
Efficiency at 220 Vac input Io = 700 mA	89.0%	91.0%	-	Measured at 100% load and steady-state temperature in 25°C ambient; (Efficiency will be about 2.0% lower if measured immediately after startup.)
Efficiency at 277 Vac input Io = 700 mA	89.0%	91.0%	-	Measured at 100% load and steady-state temperature in 25°C ambient; (Efficiency will be about 2.0% lower if measured immediately after startup.)
MTBF	-	514,000 Hours	-	Measured at 220Vac input, 80%Load and 25°C ambient temperature (MIL-HDBK-217F)
Lifetime	-	118,000 Hours	-	Measured at 220Vac input, 80%Load and 60°C case temperature; See lifetime vs. Tc curve for the details
Operating Case Temperature for Safety Tc s	-55°C	-	+90 °C	
Operating Case Temperature for Warranty Tc w	-55°C	-	+70 °C	Case temperature for 5 years warranty;
Storage Temperature	-55°C	-	+85°C	Humidity: 5%RH to 100%RH
Dimensions Inches (L × W × H) Millimeters (L × W × H)	6.22 × 2.66 × 1.44 158 × 67.5 × 36.5			With mounting ear 7.29 × 2.66 × 1.44 185 × 67.5 × 36.5

General Specifications (Continued)

Parameter	Min.	Typ.	Max.	Notes
Net Weight	-	780 g	-	

Note: All specifications are typical at 25°C unless otherwise stated.

Dimming Specifications

Parameter	Min.	Typ.	Max.	Notes
Absolute Maximum Voltage on the Vdim (+) Pin	-20 V	-	20 V	
Source Current on Vdim (+)Pin	200 µA	300 µA	450 µA	Vdim(+) = 0 V
Dimming Output Range	10%Io	-	100%Io	
Recommended Dimming Input Range	0 V	-	10 V	

Note: All specifications are typical at 25°C unless otherwise stated.

Safety & EMC Compliance

Safety Category	Standard
CE	EN 61347-1, EN61347-2-13
CB	IEC 61347-1, IEC 61347-2-13
KS	KS C 7655
EMI Standards	Notes
EN 55015 ⁽¹⁾	Conducted emission Test & Radiated emission Test
EN 61000-3-2	Harmonic current emissions
EN 61000-3-3	Voltage fluctuations & flicker
EMS Standards	Notes
EN 61000-4-2	Electrostatic Discharge (ESD): 8 kV air discharge, 4 kV contact discharge
EN 61000-4-3	Radio-Frequency Electromagnetic Field Susceptibility Test-RS
EN 61000-4-4	Electrical Fast Transient / Burst-EFT
EN 61000-4-5	Surge Immunity Test: AC Power Line: Differential Mode 4 kV, Common Mode 6 kV
EN 61000-4-6	Conducted Radio Frequency Disturbances Test-CS
EN 61000-4-8	Power Frequency Magnetic Field Test
EN 61000-4-11	Voltage Dips
EN 61547	Electromagnetic Immunity Requirements Applies To Lighting Equipment

Note: (1) This LED driver meets the EMI specifications above, but EMI performance of a luminaire that contains it depends also on the other devices connected to the driver and on the fixture itself.

Lifetime vs. Case Temperature

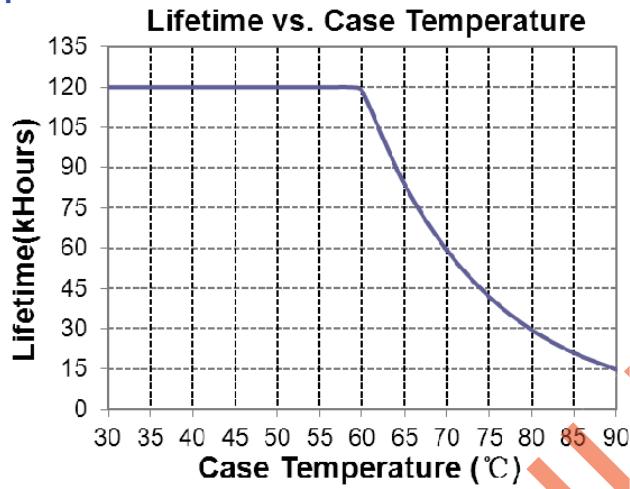

Inrush Current Waveform

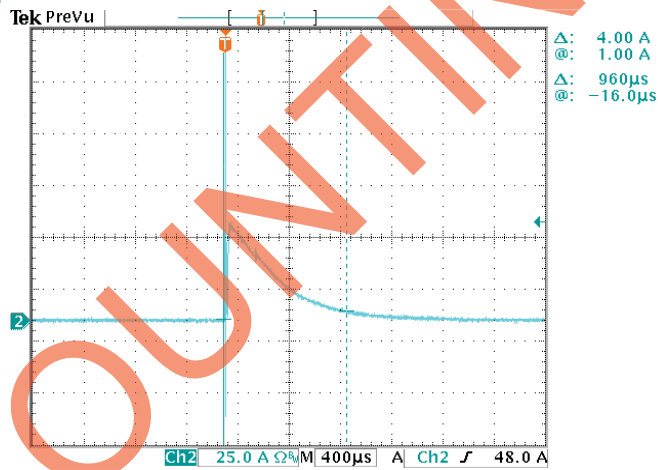

Efficiency vs. Load

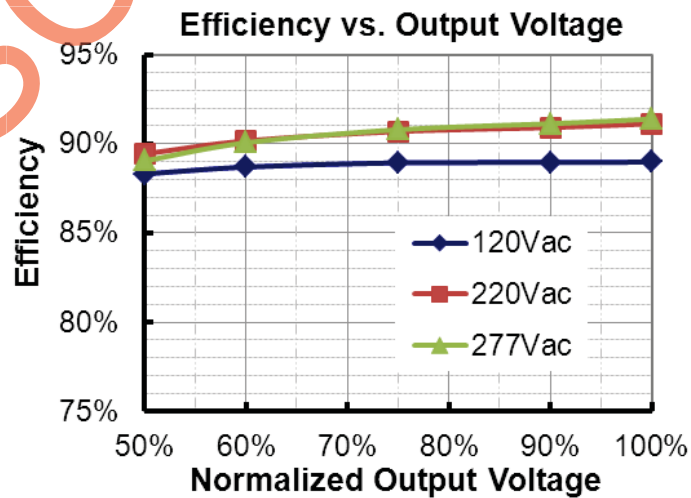

Power Factor

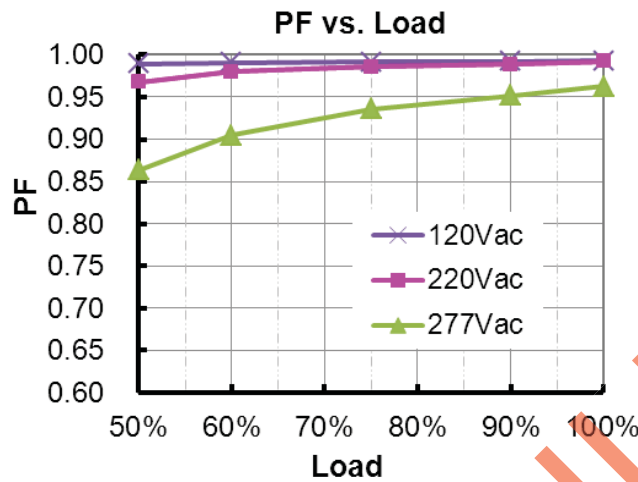

Total Harmonic Distortion

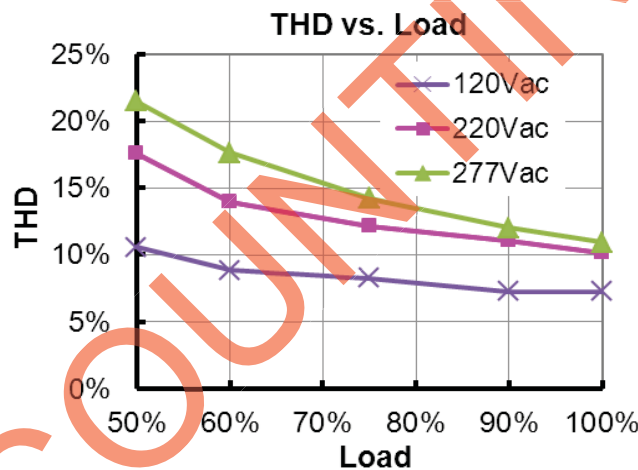

Turn-on

The turn-on operation curves are provided below, which are measured at 120Vac and 220Vac input.

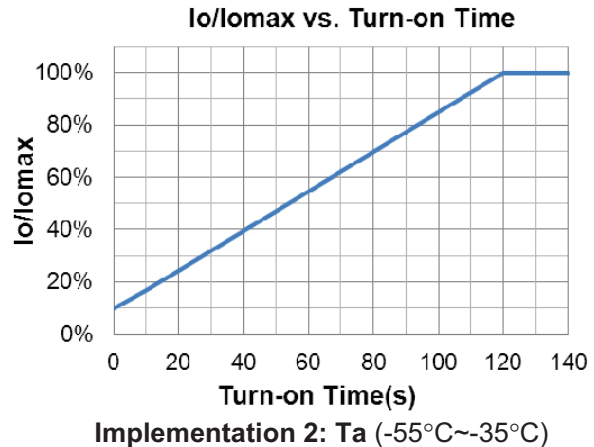
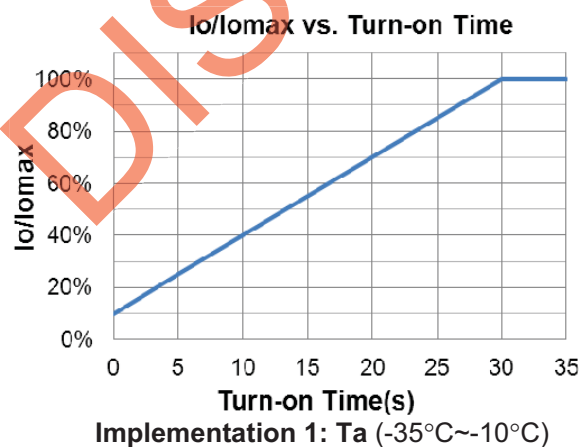

Protection Functions

Parameter	Notes
Over Temperature Protection	Decreases output current, returning to normal after over temperature is removed.
Short Circuit Protection	Auto Recovery. No damage will occur when any output is short circuited. The output shall return to normal when the fault condition is removed.
Over Voltage Protection	Limits output voltage at no load and in case the normal voltage limit fails.

Dimming

● 0-10V Dimming

The recommended implementation of the dimming control is provided below.

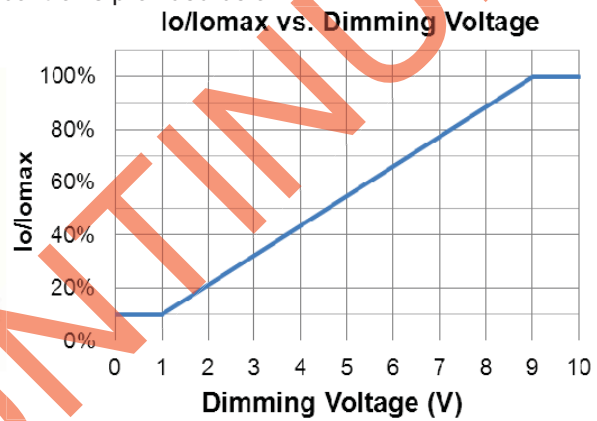
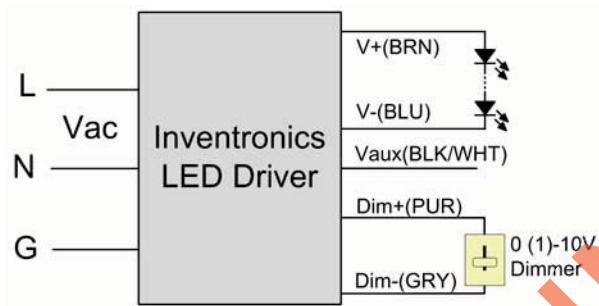

Implementation 1: DC Input

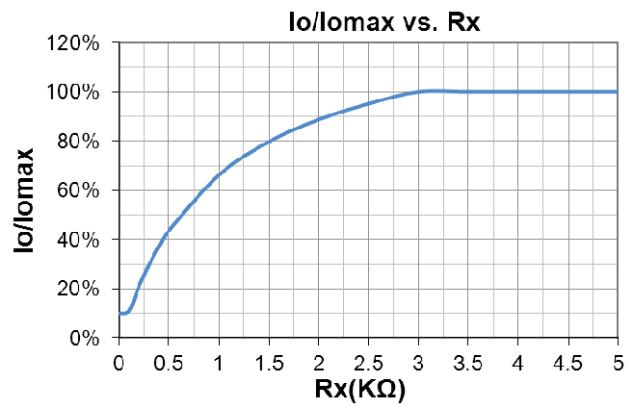
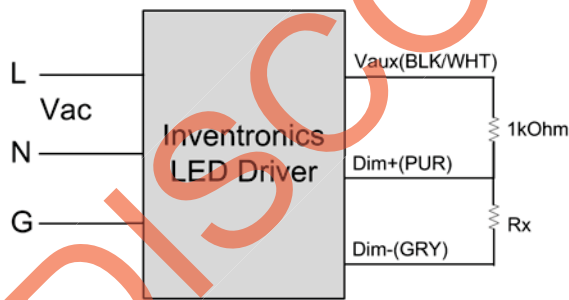

Implementation 2: External Resistor

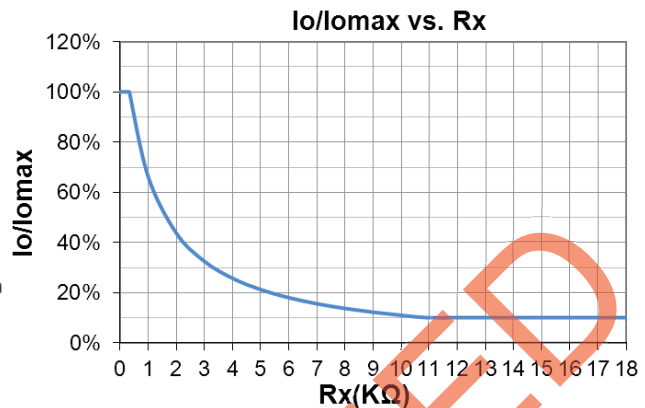
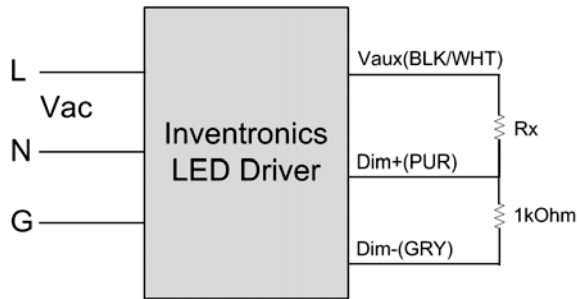

Implementation 3: External Resistor

Notes:

1. The dimmer can also be replaced by an active 0-10V voltage source signal or passive components like resistors and zener.
2. Do NOT connect Dim- to the output V- or V+, otherwise the driver will not work properly.
3. If 0-10V dimming is not used, Dim + can be either open or connected to Vaux.

Mechanical Outline

EUC-075S070DVY

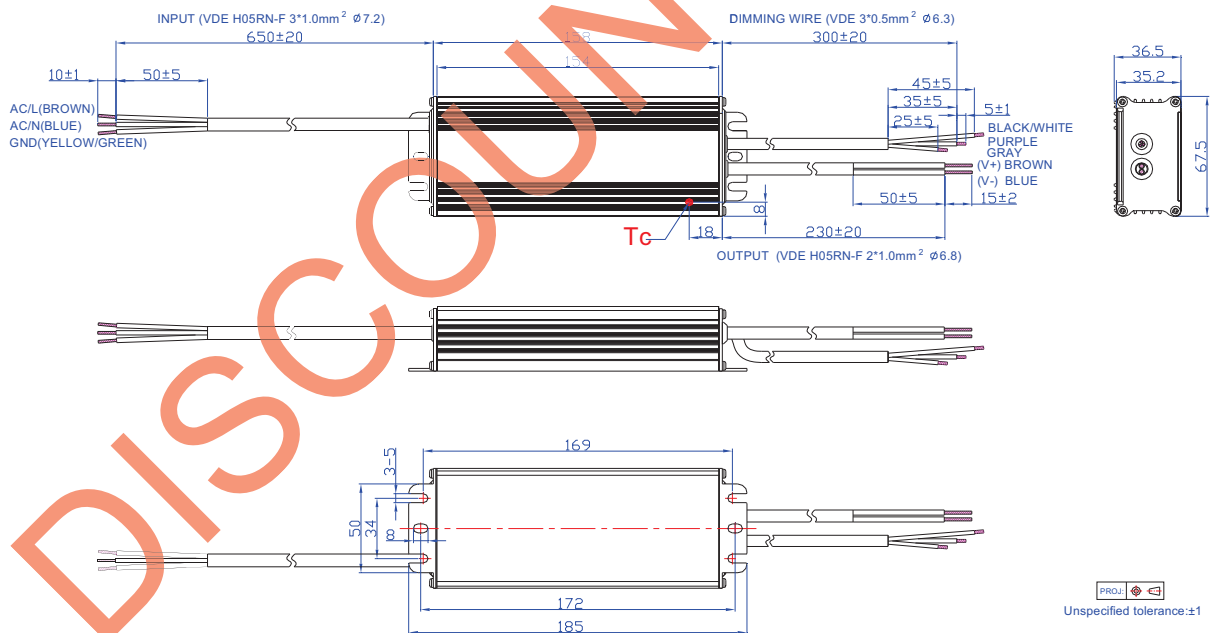

EUC-075S070SVY

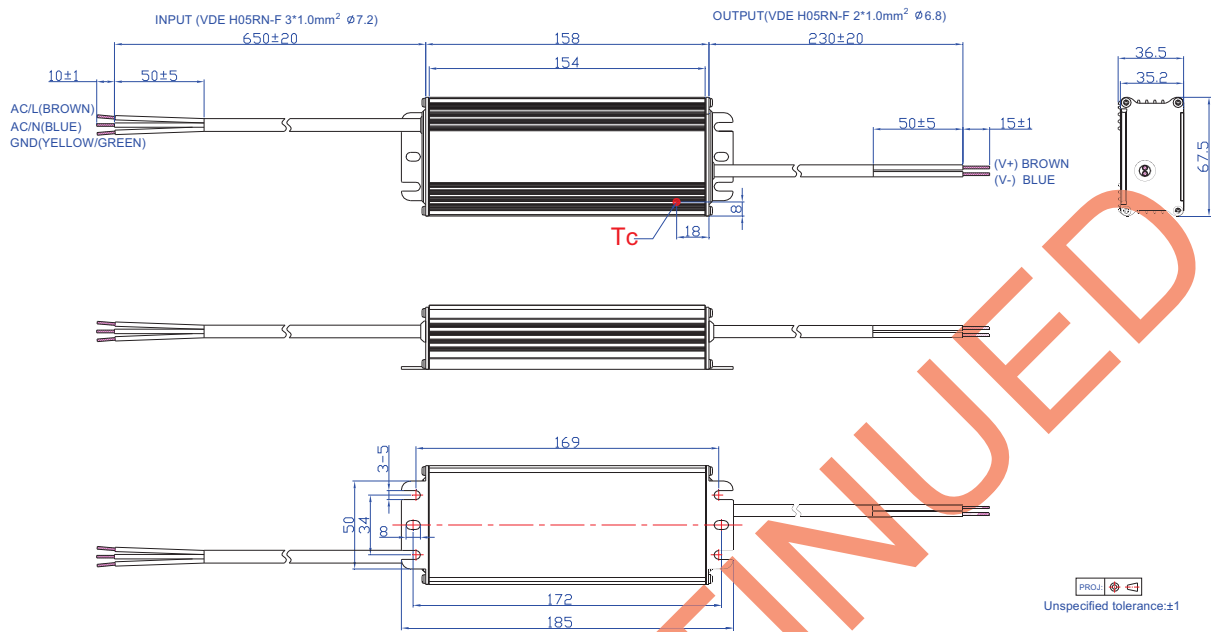

RoHS Compliance

Our products comply with reference to RoHS Directive (EU) 2015/863 amending 2011/65/EU, calling for the elimination of lead and other hazardous substances from electronic products.

Revision History

Change Date	Rev.	Description of Change		
		Item	From	To
2014-12-18	A	Datasheets Release	/	/
2019-09-19	B	TUV Logo	/	Deleted
		KS Logo	/	Added
		Features	Waterproof(IP67)	IP67
		Features	5 Years Warranty	Added
		Description	Application environment	Updated
		Input Specifications(PF/THD)	50-60Hz	Added
		General Specifications	Operating Case Temperature for Safety Tc_s	Updated
		General Specifications	Operating Case Temperature for Warranty Tc_w	Updated
		General Specifications	Storage Temperature	Added
		General Specifications	With mounting ear	Added
		Environmental Specifications	/	Deleted
		Safety &EMC Compliance	CB	Added
		Safety &EMC Compliance	KS	Added
		Safety &EMC Compliance	EN 61000-4-4	Updated
		Safety &EMC Compliance	EN 61000-4-5	Updated
		Safety &EMC Compliance	Note	Added
		Derating	/	Deleted
Mechanical Outline	/	Updated		
RoHS Compliance	/	Updated		