

Features

- High Efficiency (Up to 92%)
- Full Power at 50-100% Max Current (Constant Power)
- 0-10V/PWM/Timer Dimmable
- Dim-to-Off with Standby Power ≤ 1 W
- Input surge protection: DM 4kV, CM 6kV
- All-Around Protection: OVP, SCP, OTP
- IP67 and UL Dry / Damp / Wet Location
- SELV Output
- TYPE HL, for use in a Class I, Division 2 hazardous (Classified) location



Description

The EUD-150SxxxDT series is a 150W, constant-current, programmable LED driver that operates from 90-305 Vac input with excellent power factor. Created for high bay, tunnel and roadway lights, it provides a dim-to-off mode with low standby power. The high efficiency of these drivers and compact metal case enables them to run cooler, significantly improving reliability and extending product life. To ensure trouble-free operation, protection is provided against input surge, output over voltage, short circuit, and over temperature.

Models

Adjustable Output Current Range	Full-Power Current Range (1)	Default Output Current	Input Voltage Range(2)	Output Voltage Range	Max. Output Power	Typical Efficiency (3)	Typical Power Factor		Model Number
							120Vac	220Vac	
65-1300mA	650-1300mA	700 mA	90~305 Vac/ 127~300 Vdc	69~230Vdc	150 W	92.0%	0.99	0.96	EUD-150S130DT
130-2600mA	1300-2600mA	2100 mA	90~305 Vac/ 127~300 Vdc	35~115Vdc	150 W	91.5%	0.99	0.96	EUD-150S260DT
260-5200mA	2600-5200mA	4200 mA	90~305 Vac/ 127~300 Vdc	18 ~ 58Vdc	150 W	90.5%	0.99	0.96	EUD-150S520DT ⁽⁴⁾

- Notes:** (1) Output current range with constant power at 150W
 (2) UL, FCC certified input voltage range: 100-277Vac or 127-300Vdc; other certified input voltage range except UL & FCC: 100-240Vac or 127-250Vdc (except KS)
 (3) Measured at a 220 Vac input with 100% maximum output current and 50% maximum output voltage.
 (4) SELV Output.

I-V Operating Area

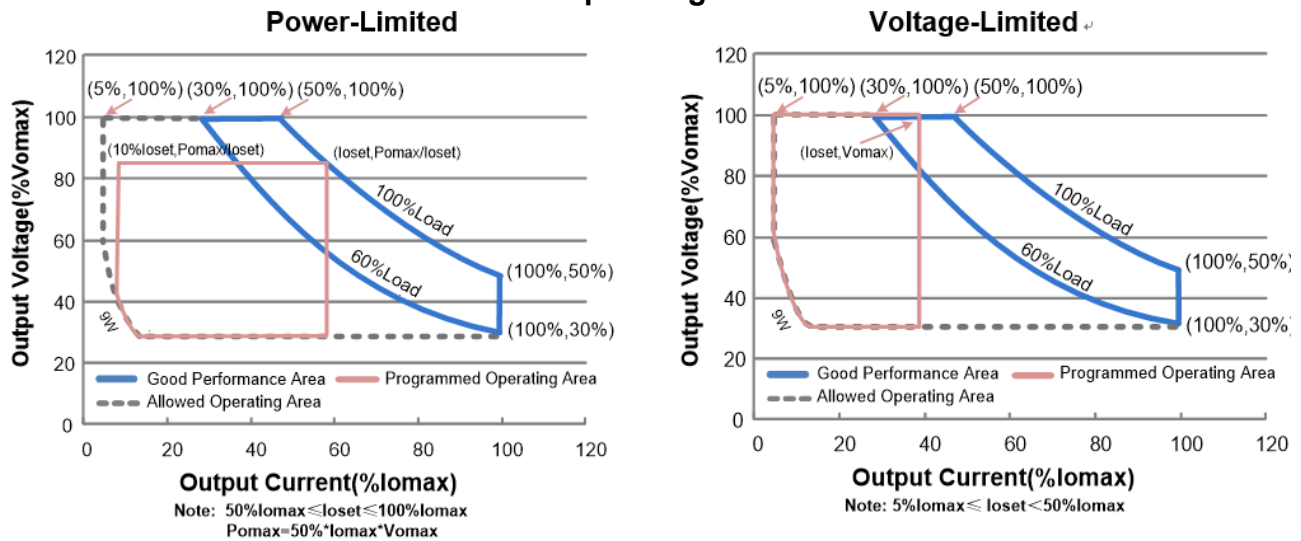

Input Specifications

Parameter	Min.	Typ.	Max.	Notes
Input AC Voltage	90 Vac	-	305 Vac	
Input DC Voltage	127 Vdc	-	300 Vdc	
Input Frequency	47 Hz	-	63 Hz	
Leakage Current	-	-	0.75 MIU	UL8750; 277Vac/ 60Hz, grounding effectively
	-	-	0.70 mA	IEC60598-1; 240Vac/ 60Hz, grounding effectively
Input AC Current	-	-	1.8 A	Measured at 100% load and 100 Vac input.
	-	-	0.85 A	Measured at 100% load and 220 Vac input.
Inrush Current(I^2t)	-	-	1.4 A ² s	At 220Vac input, 25°C Cold Start, Duration=1.46 mS, 10%Ipk-10%Ipk. See Inrush Current Waveform for the details.
PF	0.90	-	-	At 100-277Vac, 50-60Hz, 60%-100% Load (90-150W)
THD	-	-	20%	

Output Specifications

Parameter	Min.	Typ.	Max.	Notes
Output Current Tolerance	-5%Ioset	-	5%Ioset	At 100% load condition
Output Current Setting(Ioset) Range	5%Iomax	-	100%Iomax	
Output Current Setting Range with Constant Power	50%Iomax	-	100%Iomax	
Total Output Current Ripple (pk-pk)	-	5%Iomax	10%Iomax	At 100% load condition. 20 MHz BW

Output Specifications (Continued)

Parameter	Min.	Typ.	Max.	Notes
Output Current Ripple at < 200 Hz (pk-pk)	-	2%Iomax	-	At 100% load condition. Only this component of ripple is associated with visible flicker.
Startup Overshoot Current	-	-	10%Iomax	At 100% load condition
No Load Output Voltage				
EUD-150S130DT	-	-	275V	
EUD-150S260DT	-	-	138V	
EUD-150S520DT	-	-	70V	
Line Regulation	-	-	±0.5%	Measured at 100% load
Load Regulation	-	-	±1.5%	
Turn-on Delay Time	-	0.8 s	1.5 s	Measured at 120Vac and 220Vac input, 60%-100% Load
Temperature Coefficient of I _o set	-	0.03%/°C	-	Case temperature = 0°C ~T _c max
12V Auxiliary Output Voltage	10.8 V	12 V	13.2 V	
12V Auxiliary Output Source Current	0 mA	-	200 mA	Return terminal is "Dim"

General Specifications

Parameter	Min.	Typ.	Max.	Notes
Efficiency at 120 Vac input:				
EUD-150S130DT				
I _o =650 mA	86.0%	89.0%	-	Measured at 100% load and steady-state temperature in 25°C ambient; (Efficiency will be about 2.0% lower if measured immediately after startup.)
I _o =1300 mA	87.0%	90.0%	-	
EUD-150S260DT				
I _o =1300 mA	86.5%	89.5%	-	
I _o = 2600mA	86.5%	89.5%	-	
EUD-150S520DT				
I _o = 2600mA	86.5%	89.5%	-	
I _o = 5200mA	85.5%	88.5%	-	
Efficiency at 220 Vac input:				
EUD-150S130DT				
I _o =650 mA	89.0%	91.0%	-	Measured at 100% load and steady-state temperature in 25°C ambient; (Efficiency will be about 2.0% lower if measured immediately after startup.)
I _o =1300 mA	90.0%	92.0%	-	
EUD-150S260DT				
I _o =1300 mA	89.5%	91.5%	-	
I _o = 2600mA	89.5%	91.5%	-	
EUD-150S520DT				
I _o = 2600mA	89.5%	91.5%	-	
I _o = 5200mA	88.5%	90.5%	-	
Efficiency at 277 Vac input:				
EUD-150S130DT				
I _o =650 mA	89.5%	91.5%	-	Measured at 100% load and steady-state temperature in 25°C ambient; (Efficiency will be about 2.0% lower if measured immediately after startup.)
I _o =1300 mA	90.5%	92.5%	-	
EUD-150S260DT				
I _o =1300 mA	89.5%	91.5%	-	
I _o = 2600mA	90.0%	92.0%	-	
EUD-150S520DT				
I _o = 2600mA	89.5%	91.5%	-	
I _o = 5200mA	89.0%	91.0%	-	

General Specifications (Continued)

Parameter	Min.	Typ.	Max.	Notes
Standby power	-	-	1 W	Measured at 230Vac/50Hz; Dimming off
MTBF	-	236,000 Hours	-	Measured at 220Vac input, 80%Load and 25°C ambient temperature (MIL-HDBK-217F)
Lifetime	-	120,000 Hours	-	Measured at 220Vac input, 80%Load and 60°C case temperature; See lifetime vs. Tc curve for the details
Operating Case Temperature for Safety Tc _s	-40°C	-	+89°C	
Operating Case Temperature for Warranty Tc _w	-40°C	-	+70°C	Humidity: 10%RH to 95%RH
Storage Temperature	-40°C	-	+85°C	Humidity: 5%RH to 95%RH
Dimensions Inches (L × W × H) Millimeters (L × W × H)	8.62 × 2.66 × 1.56 219 × 67.5 × 39.5			With mounting ear 9.67 × 2.66 × 1.56 246 × 67.5 × 39.5
Net Weight	-	1210 g	-	

Dimming Specifications

Parameter	Min.	Typ.	Max.	Notes
Absolute Maximum Voltage on the Vdim (+) Pin	-20 V	-	20 V	
Source Current on Vdim (+) Pin	200 uA	300 uA	450 uA	Vdim(+) = 0 V
Dimming Output Range	10%loset	-	loset	50%lomax ≤ loiset ≤ 100%lomax
	5%lomax	-	loset	5%lomax ≤ loiset < 50%lomax
Recommended Dimming Input Range	0 V	-	10 V	Default 0-10V dimming mode.
Dim off Voltage	0.2 V	0.4 V	0.6 V	
Dim on Voltage	0.4 V	0.6 V	0.8 V	
Hysteresis	-	0.2 V	-	

Dimming Specifications (Continued)

Parameter	Min.	Typ.	Max.	Notes
PWM_in High Level	3 V	-	10 V	Dimming mode set to PWM in PC interface.
PWM_in Low Level	-0.3 V	-	0.6 V	
PWM_in Frequency Range	200 Hz	-	3 KHz	
PWM_in Duty Cycle	1%	-	99%	
PWM Dimming off (Positive Logic)	2%	4%	7%	
PWM Dimming on (Positive Logic)	4%	6%	9%	
PWM Dimming off (Negative Logic)	93%	96%	98%	
PWM Dimming on (Negative Logic)	91%	94%	96%	
Hysteresis	-	2%	-	

Safety & EMC Compliance

Safety Category	Standard
UL/CUL	UL8750 & CAN/CSA-C22.2 No. 250.13
CE ⁽¹⁾	EN 61347-1, EN 61347-2-13
KS	KS C 7655
EMI Standards	Notes
EN 55015 ⁽²⁾	Conducted emission Test & Radiated emission Test
EN 61000-3-2	Harmonic current emissions
EN 61000-3-3	Voltage fluctuations & flicker
FCC Part 15 ⁽²⁾	ANSI C63.4 Class B
	This device complies with Part 15 of the FCC Rules. Operation is subject to the following two conditions: [1] this device may not cause harmful interference, and [2] this device must accept any interference received, including interference that may cause undesired Operation.
EMS Standards	Notes
EN 61000-4-2	Electrostatic Discharge(ESD): 8kV air discharge, 4kV contact discharge
EN 61000-4-3	Radio-Frequency Electromagnetic Field Susceptibility Test-RS
EN 61000-4-4	Electrical Fast Transient/Burst-EFT
EN 61000-4-5	Surge Immunity Test: AC Power Line: Differential Mode 4 kV, Common Mode 6 kV ⁽³⁾
EN 61000-4-6	Conducted Radio Frequency Disturbances test-CS
EN 61000-4-8	Power Frequency Magnetic Field Test

Safety & EMC Compliance (Continued)

EMS Standards	Notes
EN 61000-4-11	Voltage Dips
EN 61547	Electromagnetic Immunity Requirements Applies To Lighting Equipment

- Note:** (1) For compliance with EU Directive 2009/125/EC (ecodesign requirements for energy-related products) the Dim-to-Off function shall not be used or alternatively be interrupted through use of a relay or similar device to prevent excessive standby power consumption (as illustrated in Implementation 4).
- (2) This LED driver meets the EMI specifications above, but EMI performance of a luminaire that contains it depends also on the other devices connected to the driver and on the fixture itself.
- (3) To perform electric strength (hi-pot) testing, the "GDT ground disconnect" (nut and metal lock sheet) on the driver end-cap should be removed temporarily to prevent the internal gas discharge tube from conducting (as allowed by IEC 60598-1 Clause 10.2). After testing is completed, these items must be reinstalled to restore line-to-earth surge protection and secure the end cap.

Lifetime vs. Case Temperature

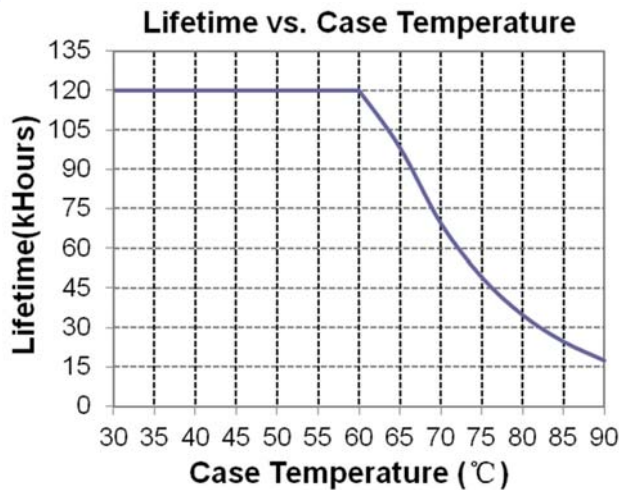

Inrush Current Waveform

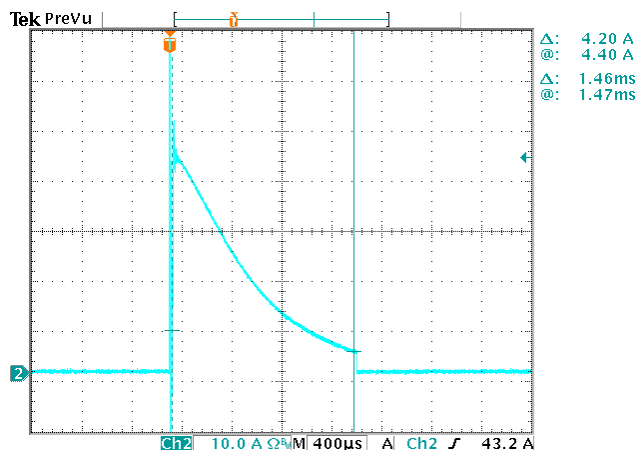

Efficiency vs. Load

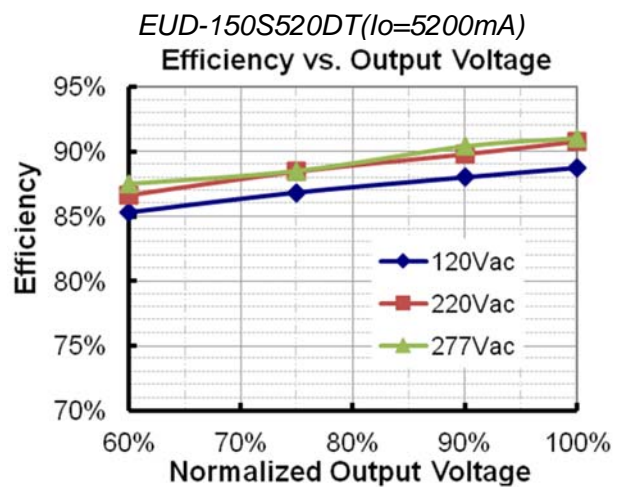
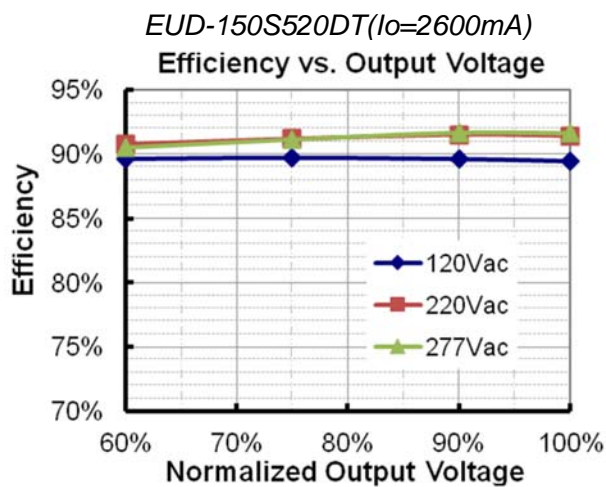
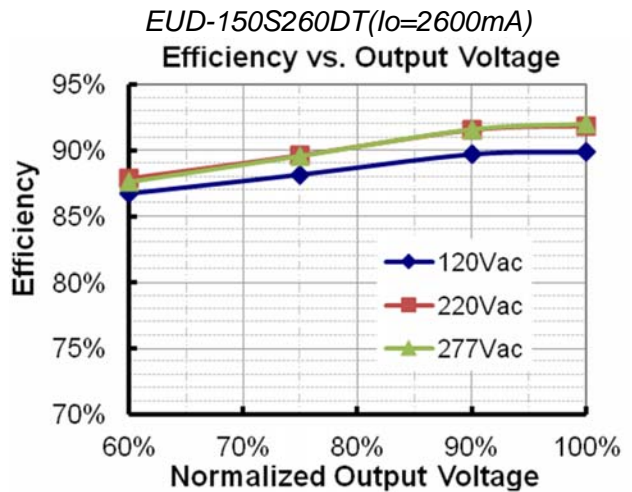
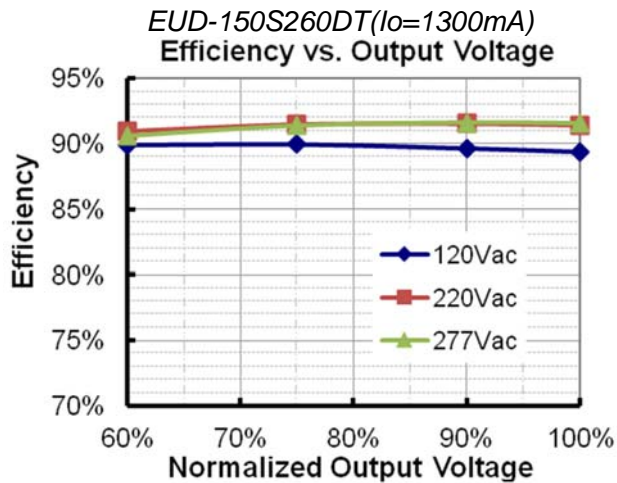
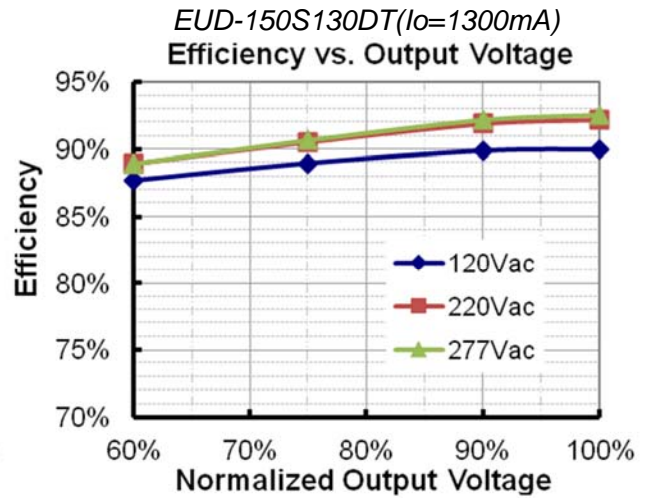
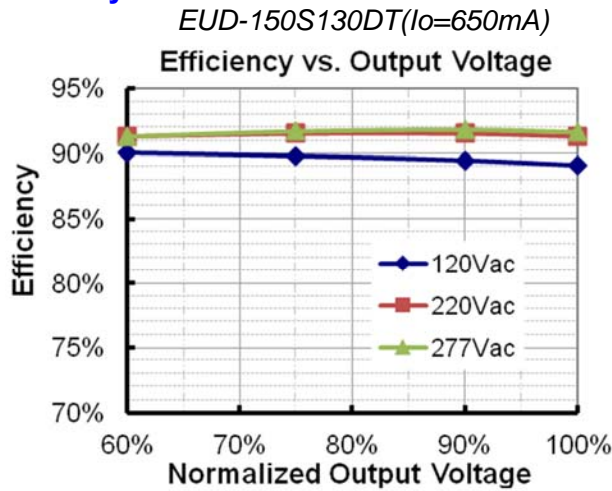

Power Factor

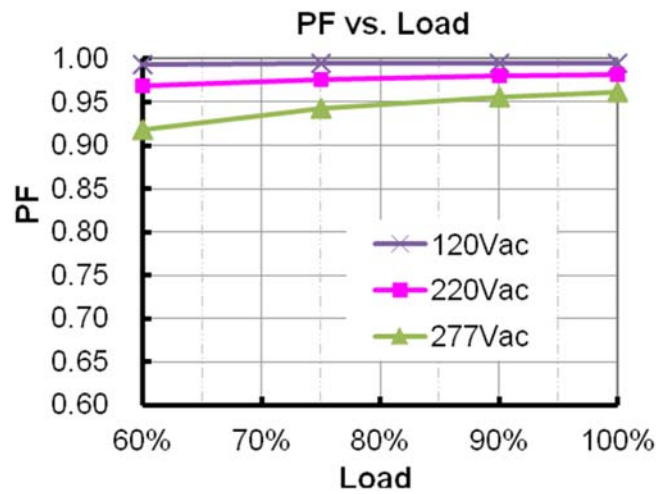

Total Harmonic Distortion

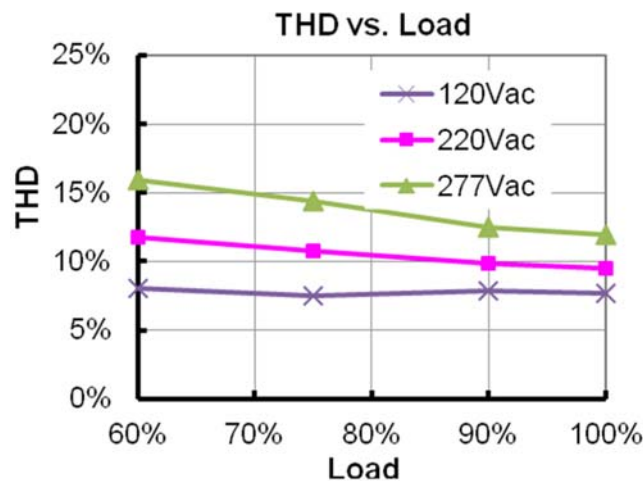

Protection Functions

Parameter	Notes
Over Temperature Protection	Decreases output current, returning to normal after over temperature is removed.
Short Circuit Protection	Auto Recovery. No damage will occur when any output is short circuited. The output shall return to normal when the fault condition is removed.
Over Voltage Protection	Limits output voltage at no load and in case the normal voltage limit fails.

Dimming

● 0-10V Dimming

The recommended implementation of the dimming control is provided below.

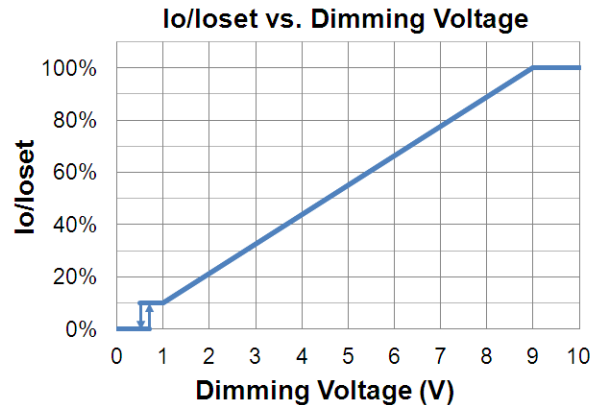
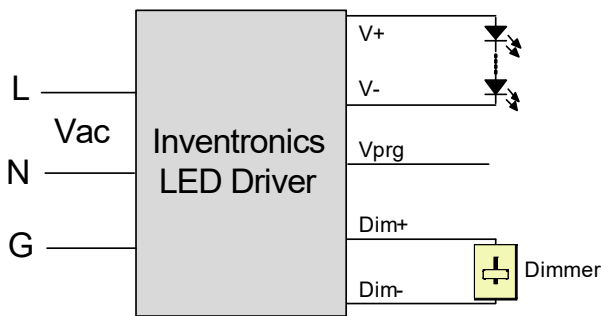

Implementation 1: DC Input

Notes:

1. Do NOT connect Dim- to the output V- or V+, otherwise the driver will not work properly.
2. The dimmer can also be replaced by an active 0-10V voltage source signal or passive components like zener.

● **PWM Dimming**

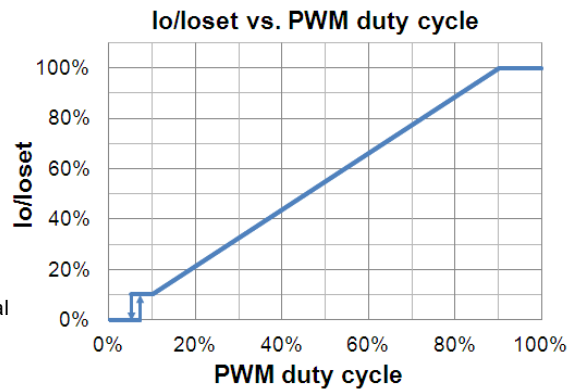
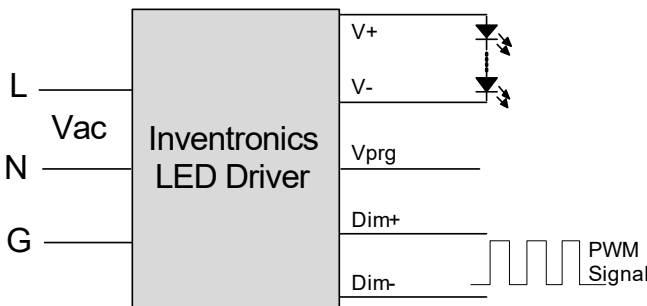

Implementation 2: Positive logic

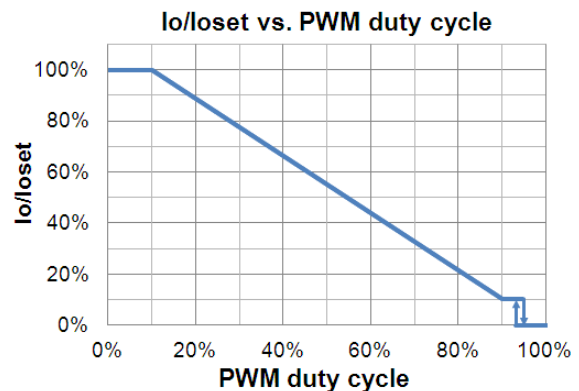
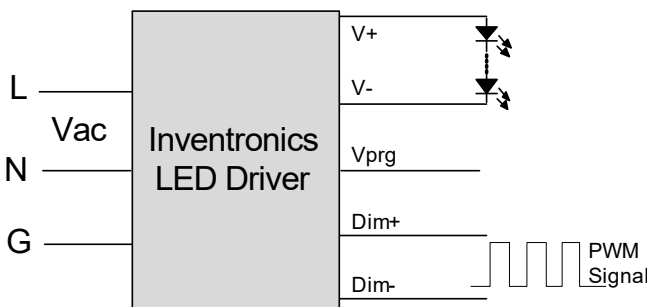

Implementation 3: Negative logic

Notes:

1. Do NOT connect Dim- to the output V- or V+, otherwise the driver will not work properly.
2. When PWM negative logic dimming mode and Dim+ is open, the driver will output minimum current.

● Time Dimming

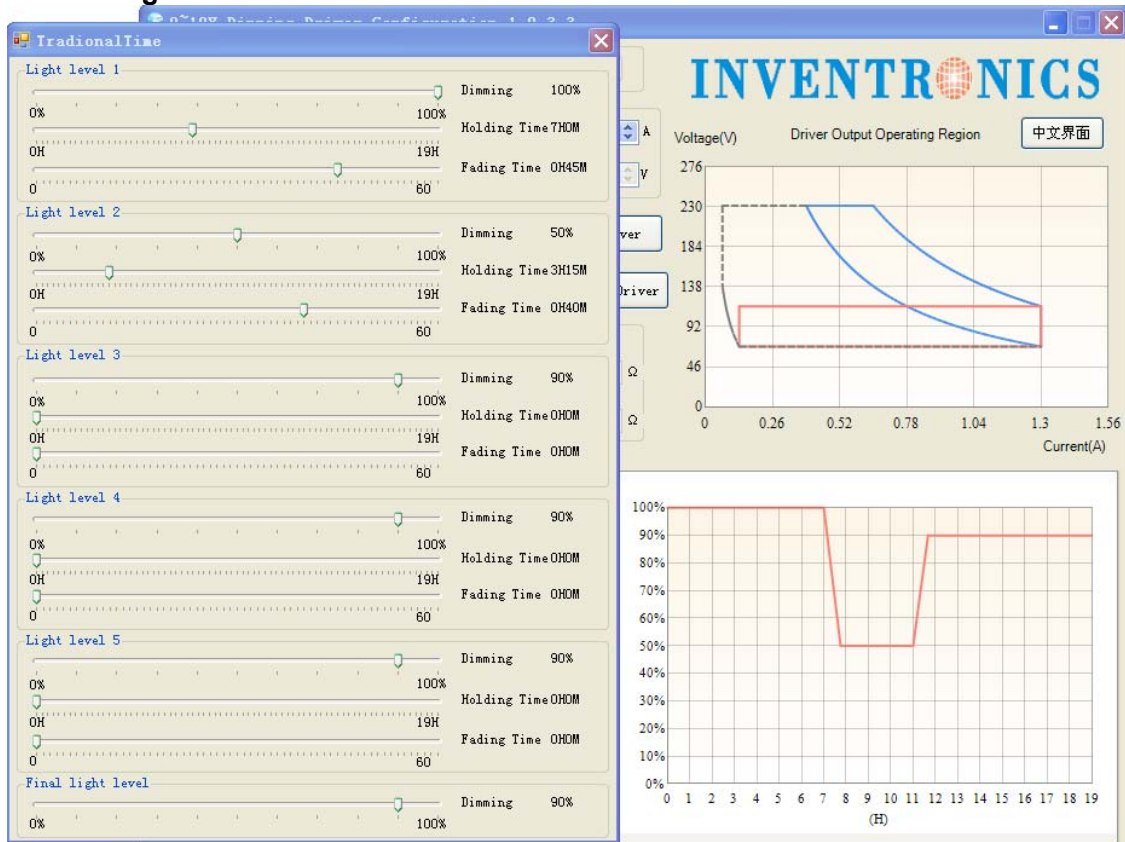

Set the timing curve by pulling the sliders.

● 0% Light Brightness

If the brightness of the LED lighting fixture down to 0%, please refer to the following wiring method. The lamp can be turned on/off using a switch and relay.

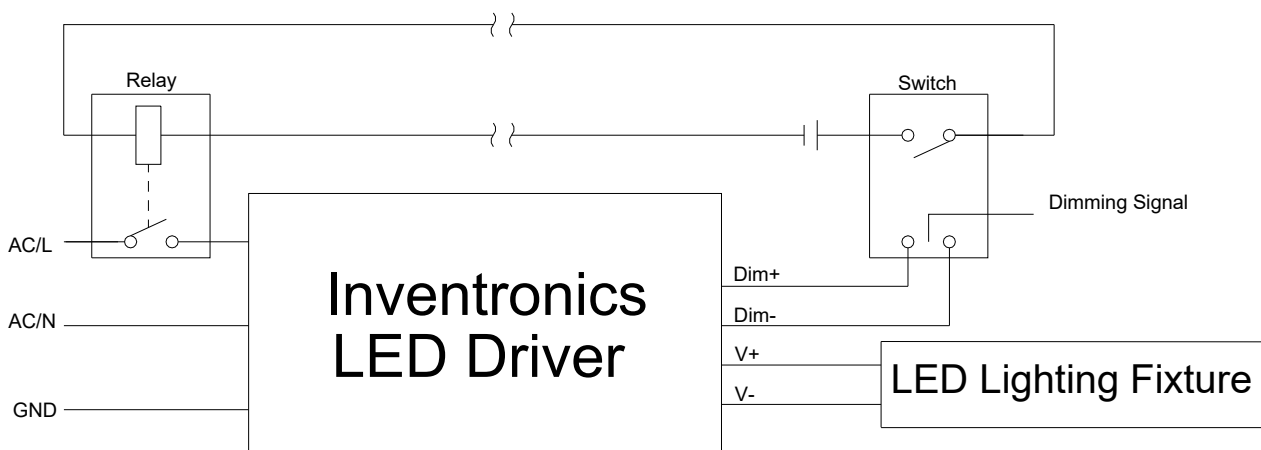

Implementation 4: 0% Light Brightness Wiring Method

Programming Connection Diagram

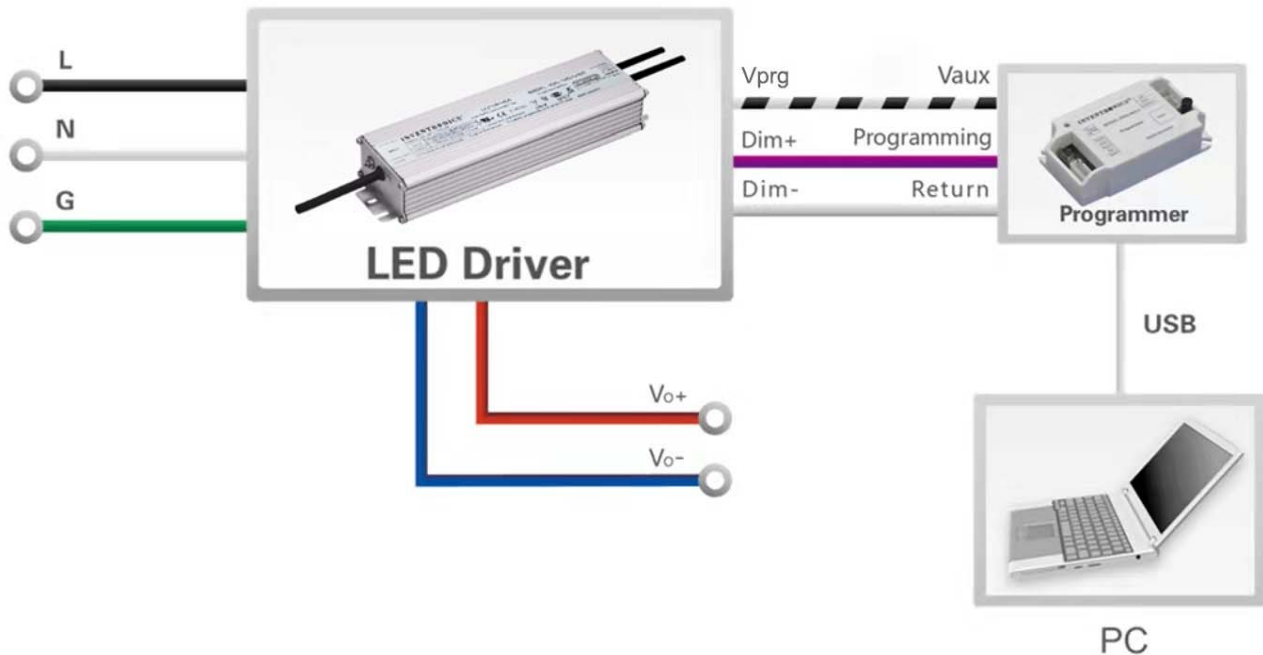

Note: The driver does not need to be powered on during the programming process.

- Please refer to [PRG-MUL2 Multi-Programmer datasheet](#) for details.

Mechanical Outline

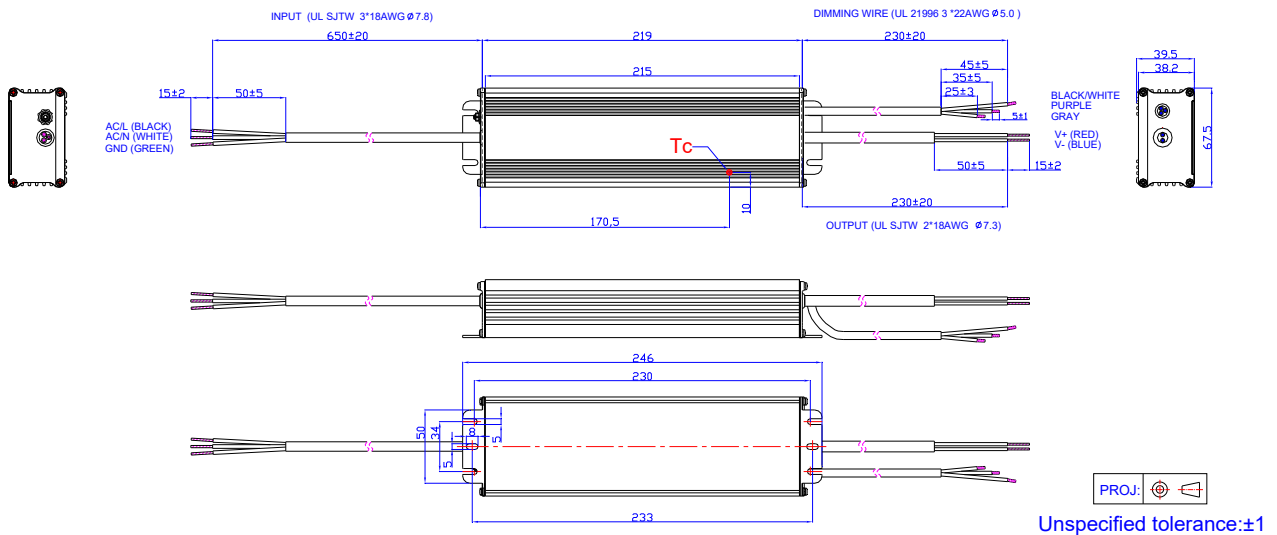

RoHS Compliance

Our products comply with reference to RoHS Directive (EU) 2015/863 amending 2011/65/EU, calling for the elimination of lead and other hazardous substances from electronic products.

Revision History

Change Date	Rev.	Description of Change		
		Item	From	To
2013-10-30	A	Datasheets Release	/	/
2015-03-09	B	Features	Input Surge Protection: 4kV line-line, 6kV line-earth	Added
		Output Current Ripple(pk-pk)	Output Current Ripple(pk-pk)	Total Output Current Ripple (pk-pk)
		Output Current Ripple at < 200 Hz (pk-pk)	/	Added
		Case Temperature	Case Temperature	Operating Case Temperature for Safety Tc_s
		Operating Case Temperature for Warranty Tc_w	/	Added
		General Specifications	Storage Temperature	Added
		Environmental Specifications	/	Deleted
		Safety & EMC Compliance	EN 55015 EN 61000-3-2 EN 61000-3-3	Deleted
		Derating	/	Deleted
2015-11-18	C	CE、KS	/	Added
		External Grounding Screw Solution	/	/
		Safety & EMC Compliance	/	Updated
		Mechanical Outline	/	Updated
2016-04-13	D	General Specifications	With mounting ear	Added
		General Specifications	Net Weight	Updated
		Safety & EMC Compliance	/	Updated
2017-07-26	E	Features	/	Updated
		Models	/	Updated
		PF/THD	Notes	Updated
		Turn-on Delay Time	Notes	Updated
		Output Specifications	Temperature Coefficient of Ioset	Updated
		Safety & EMC Compliance	/	Updated
		Mechanical Outline	/	Updated
2021-11-26	F	Features	/	Updated
		Safety & EMC Compliance	Note (1)	Updated
		0% Light Brightness	/	Added