

## Features

- High Efficiency (Up to 91%)
- Full Power at Wide Output Current Range (Constant Power)
- 0-5V/0-10V/PWM/Timer Dimmable
- Input Surge Protection: DM 6kV, CM 10kV
- All-Around Protection: OVP, SCP, OTP
- IP67
- SELV Output
- 7 Years Warranty



## Description

The EUG-075SxxxDV series is a 75W, constant-current, programmable LED driver that operates from 90-305 Vac input with excellent power factor. It is created for many lighting applications including low bay, tunnel and street, etc. The high efficiency of these drivers and compact metal case enables them to run cooler, significantly improving reliability and extending product life. To ensure trouble-free operation, protection is provided against input surge, output over voltage, short circuit, and over temperature.

## Models

| Adjustable Output Current Range | Full-Power Current Range (1) | Default Output Current | Input Voltage Range(2)     | Output Voltage Range | Max. Output Power | Typical Efficiency (3) | Typical Power Factor |        | Model Number                 |
|---------------------------------|------------------------------|------------------------|----------------------------|----------------------|-------------------|------------------------|----------------------|--------|------------------------------|
|                                 |                              |                        |                            |                      |                   |                        | 120Vac               | 220Vac |                              |
| 45-700mA                        | 450-700mA                    | 530 mA                 | 90~305 Vac/<br>127~250 Vdc | 54~167Vdc            | 75 W              | 91.0%                  | 0.99                 | 0.96   | EUG-075S070DV                |
| 70-1050mA                       | 700-1050mA                   | 700 mA                 | 90~305 Vac/<br>127~250 Vdc | 36~107Vdc            | 75 W              | 90.5%                  | 0.99                 | 0.96   | EUG-075S105DV <sup>(4)</sup> |
| 119-1750mA                      | 1190-1750mA                  | 1400 mA                | 90~305 Vac/<br>127~250 Vdc | 22 ~ 63Vdc           | 75 W              | 90.0%                  | 0.99                 | 0.96   | EUG-075S175DV <sup>(4)</sup> |
| 192-2800mA                      | 1920-2800mA                  | 2100 mA                | 90~305 Vac/<br>127~250 Vdc | 14 ~ 39Vdc           | 75 W              | 89.0%                  | 0.99                 | 0.96   | EUG-075S280DV <sup>(4)</sup> |

- Notes:** (1) Output current range with constant power at 75W.  
 (2) Certified input Voltage range 100-240Vac or 127-250Vdc (except CCC, KS and BIS).  
 (3) Measured at 100% load and 220Vac input (see below "General Specifications" for details).  
 (4) SELV output.  
 (5) For BIS models add suffix -3000.

## I-V Operating Area

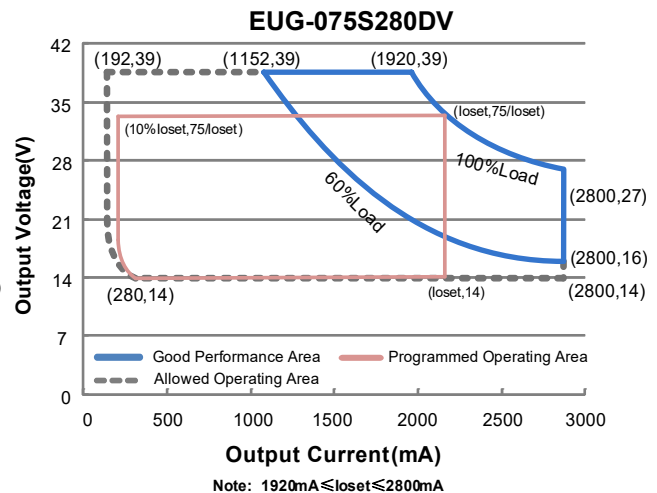
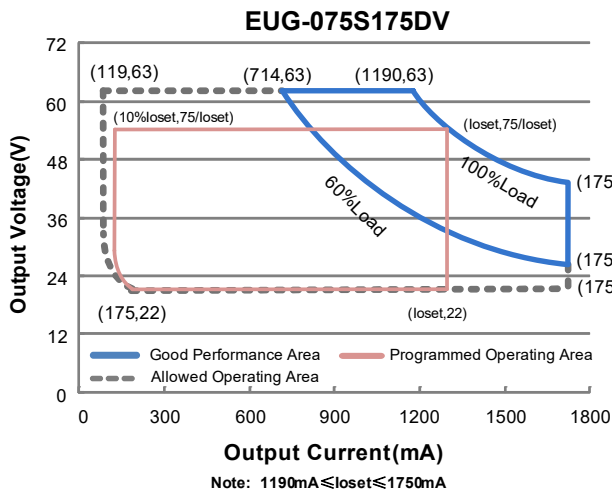
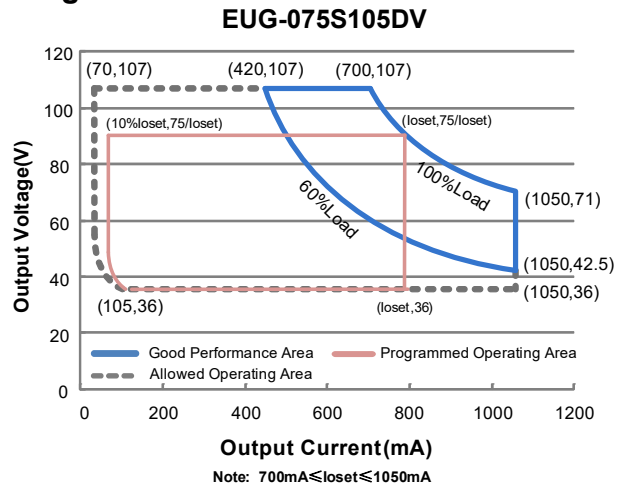
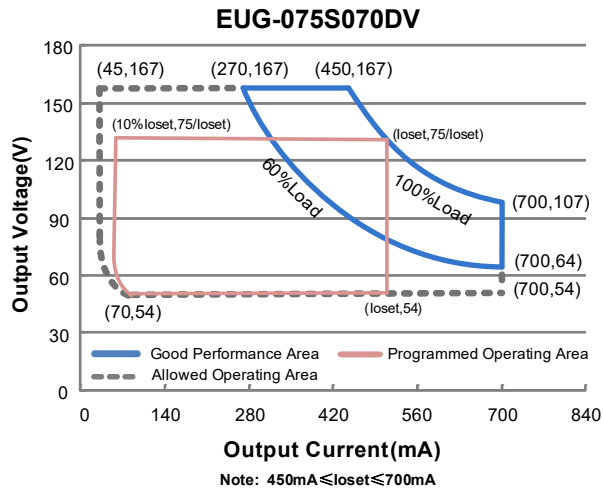

## Input Specifications

| Parameter                        | Min.    | Typ. | Max.                 | Notes  |
|----------------------------------|---------|------|----------------------|--|
| Input AC Voltage                 | 90 Vac  | -    | 305 Vac              |  |
| Input DC Voltage                 | 127 Vdc | -    | 250 Vdc              |  |
| Input Frequency                  | 47 Hz   | -    | 63 Hz                |  |
| Leakage Current                  | -       | -    | 0.70 mA              | IEC 60598-1; 240Vac/ 60Hz, grounding effectively   |
| Input AC Current                 | -       | -    | 1.05 A               | Measured at 100% load and 100 Vac input.   |
|                                  | -       | -    | 0.48 A               | Measured at 100%load and 220 Vac input.  |
| Inrush Current(I <sup>2</sup> t) | -       | -    | 1.3 A <sup>2</sup> s | At 220Vac input, 25°C cold start, duration=456 μs, 10%Ipk-10%Ipk. See Inrush Current Waveform for the details. |

## Input Specifications (Continued)

| Parameter | Min. | Typ. | Max. | Notes   |
|-----------|------|------|------|---|
| PF        | 0.9  | -    | -    | At 100-240Vac, 50-60Hz, 60%-100% Load (45-75W)    |
| THD       | -    | -    | 20%  |   |
| THD       | -    | -    | 10%  | At 220-240Vac, 50-60Hz, 75%-100% Load (56.25-75W) |

## Output Specifications

| Parameter  | Min.     | Typ.     | Max.     | Notes  |
|--|----------|----------|----------|--|
| Output Current Tolerance                         | -5%loset | -        | 5%loset  | At 100%load condition  |
| Output Current Setting(loset) Range              |          |          |          |  |
| EUG-075S070DV                                    | 45 mA    | -        | 700 mA   |  |
| EUG-075S105DV                                    | 70 mA    | -        | 1050 mA  |  |
| EUG-075S175DV                                    | 119 mA   | -        | 1750 mA  |  |
| EUG-075S280DV                                    | 192 mA   | -        | 2800 mA  |  |
| Output Current Setting Range with Constant Power |          |          |          |  |
| EUG-075S070DV                                    | 450 mA   | -        | 700 mA   |  |
| EUG-075S105DV                                    | 700 mA   | -        | 1050 mA  |  |
| EUG-075S175DV                                    | 1190 mA  | -        | 1750 mA  |  |
| EUG-075S280DV                                    | 1920 mA  | -        | 2800 mA  |  |
| Total Output Current Ripple (pk-pk)              | -        | 5%lomax  | 10%lomax | At 100%load condition. 20 MHz BW   |
| Output Current Ripple at < 200 Hz (pk-pk)        | -        | 1%lomax  | -        | At 100%load condition. Only this component of ripple is associated with visible flicker. |
| Startup Overshoot Current                        | -        | -        | 10%lomax | At 100%load condition  |
| No Load Output Voltage                           |          |          |          |  |
| EUG-075S070DV                                    | -        | -        | 180 V    |  |
| EUG-075S105DV                                    | -        | -        | 118 V    |  |
| EUG-075S175DV                                    | -        | -        | 67 V     |  |
| EUG-075S280DV                                    | -        | -        | 48 V     |  |
| Line Regulation                                  | -        | -        | ±0.5%    | Measured at 100%load   |
| Load Regulation                                  | -        | -        | ±1.5%    |  |
| Turn-on Delay Time                               | -        | -        | 1.0 s    | Measured at 120Vac input, 60%-100% Load  |
|  | -        | -        | 0.5 s    | Measured at 220Vac input, 60%-100% Load  |
| Temperature Coefficient of loset                 | -        | 0.03%/°C | -        | Case temperature = 0°C ~Tc max   |
| 12V Auxiliary Output Voltage                     | 10.8 V   | 12 V     | 13.2 V   |  |
| 12V Auxiliary Output Source Current              | 0 mA     | -        | 20 mA    | Return terminal is "Dim"   |

## General Specifications

| Parameter                                     | Min.               | Typ.          | Max.  | Notes   |
|---|--------------------|---------------|-------|---|
| Efficiency at 120 Vac input:<br>EUG-075S070DV |                    |               |       | Measured at 100%load and steady-state temperature in 25°C ambient; (Efficiency will be about 2.0% lower if measured immediately after startup.) |
| Io= 450mA                                     | 86.0%              | 88.0%         | -     |   |
| Io= 700mA                                     | 87.0%              | 89.0%         | -     |   |
| EUG-075S105DV                                 |                    |               |       |   |
| Io= 700mA                                     | 86.0%              | 88.0%         | -     |   |
| Io=1050mA                                     | 86.5%              | 88.5%         | -     |   |
| EUG-075S175DV                                 |                    |               |       |   |
| Io=1190mA                                     | 85.5%              | 87.5%         | -     |   |
| Io=1750mA                                     | 86.0%              | 88.0%         | -     |   |
| EUG-075S280DV                                 |                    |               |       |   |
| Io=1920mA                                     | 85.5%              | 87.5%         | -     |   |
| Io=2800mA                                     | 84.5%              | 86.5%         | -     |   |
| Efficiency at 220 Vac input:<br>EUG-075S070DV |                    |               |       | Measured at 100%load and steady-state temperature in 25°C ambient; (Efficiency will be about 2.0% lower if measured immediately after startup.) |
| Io= 450mA                                     | 88.5%              | 90.5%         | -     |   |
| Io= 700mA                                     | 89.0%              | 91.0%         | -     |   |
| EUG-075S105DV                                 |                    |               |       |   |
| Io= 700mA                                     | 88.0%              | 90.0%         | -     |   |
| Io=1050mA                                     | 88.5%              | 90.5%         | -     |   |
| EUG-075S175DV                                 |                    |               |       |   |
| Io=1190mA                                     | 87.5%              | 89.5%         | -     |   |
| Io=1750mA                                     | 88.0%              | 90.0%         | -     |   |
| EUG-075S280DV                                 |                    |               |       |   |
| Io=1920mA                                     | 87.5%              | 89.5%         | -     |   |
| Io=2800mA                                     | 87.0%              | 89.0%         | -     |   |
| Efficiency at 277 Vac input:<br>EUG-075S070DV |                    |               |       | Measured at 100%load and steady-state temperature in 25°C ambient; (Efficiency will be about 2.0% lower if measured immediately after startup.) |
| Io= 450mA                                     | 89.0%              | 91.0%         | -     |   |
| Io= 700mA                                     | 89.0%              | 91.0%         | -     |   |
| EUG-075S105DV                                 |                    |               |       |   |
| Io= 700mA                                     | 88.0%              | 90.0%         | -     |   |
| Io=1050mA                                     | 88.5%              | 90.5%         | -     |   |
| EUG-075S175DV                                 |                    |               |       |   |
| Io=1190mA                                     | 88.0%              | 90.0%         | -     |   |
| Io=1750mA                                     | 88.5%              | 90.5%         | -     |   |
| EUG-075S280DV                                 |                    |               |       |   |
| Io=1920mA                                     | 88.0%              | 90.0%         | -     |   |
| Io=2800mA                                     | 87.0%              | 89.0%         | -     |   |
| MTBF  | -                  | 328,000 Hours | -     | Measured at 220Vac input, 80%Load and 25°C ambient temperature (MIL-HDBK-217F)  |
| Lifetime                                      | -                  | 99,000 Hours  | -     | Measured at 220Vac input, 80%Load and 70°C case temperature; See lifetime vs. Tc curve for the details  |
| Operating Case Temperature for Safety Tc_s    | -40°C              | -             | +90°C |   |
| Operating Case Temperature for Warranty Tc_w  | -40°C              | -             | +75°C | Case temperature for 7 years warranty. Please see <i>Inventronics Warranty Statement</i> for complete details.                                  |
| Storage Temperature                           | -40°C              | -             | +85°C | Humidity: 5%RH to 100%RH  |
| Dimensions                                    |                    |               |       | With mounting ear   |
| Inches (L x W x H)                            | 5.91 x 2.66 x 1.44 |               |       | 6.97 x 2.66 x 1.44  |
| Millimeters (L x W x H)                       | 150 x 67.5 x 36.5  |               |       | 177 x 67.5 x 36.5   |
| Net Weight                                    | -                  | 790 g         | -     |   |

## Dimming Specifications

| Parameter                                    |  | Min.                               | Typ.        | Max.        | Notes   |
|--|--|------------------------------------|-------------|-------------|---|
| Absolute Maximum Voltage on the Vdim (+) Pin |  | -20 V                              | -           | 20 V        |   |
| Source Current on Vdim (+)Pin                |  | 200 $\mu$ A                        | 300 $\mu$ A | 450 $\mu$ A | Vdim(+) = 0 V   |
| Dimming Output Range                         | EUG-075S070DV<br>EUG-075S105DV<br>EUG-075S175DV<br>EUG-075S280DV | 10%loset                           | -           | loset       | 450 mA $\leq$ loset $\leq$ 700 mA<br>700 mA $\leq$ loset $\leq$ 1050 mA<br>1190 mA $\leq$ loset $\leq$ 1750 mA<br>1920 mA $\leq$ loset $\leq$ 2800 mA |
|  | EUG-075S070DV<br>EUG-075S105DV<br>EUG-075S175DV<br>EUG-075S280DV | 45 mA<br>70 mA<br>119 mA<br>192 mA | -           | loset       | 45 mA $\leq$ loset < 450 mA<br>70 mA $\leq$ loset < 700 mA<br>119 mA $\leq$ loset < 1190 mA<br>192 mA $\leq$ loset < 1920 mA                          |
| Recommended Dimming Range for 0-5V           |  | 0 V                                | -           | 5 V         | Dimming mode set to 0-5V in Inventronics programming software.  |
| Recommended Dimming Range for 0-10V          |  | 0 V                                | -           | 10 V        | Default 0-10V dimming mode with positive logic.   |
| PWM_in High Level                            |  | 3 V                                | -           | 10 V        | Dimming mode set to PWM in nventronics programming software.  |
| PWM_in Low Level                             |  | -0.3 V                             | -           | 0.6 V       |   |
| PWM_in Frequency Range                       |  | 200 Hz                             | -           | 2 KHz       |   |
| PWM_in Duty Cycle                            |  | 1%                                 | -           | 99%         |   |

## Safety & EMC Compliance

| Safety Category                              | Standard   |
|--|--|
| ENEC & CE                                    | EN 61347-1, EN 61347-2-13  |
| CB   | IEC 61347-1, IEC 61347-2-13  |
| CCC  | GB 19510.1, GB 19510.14  |
| KS   | KS C 7655  |
| BIS  | IS 15885(Part2/Sec13)  |
| SAA  | AS/NZS 61347.1, AS/NZS 61347.2.13  |
| EMI Standards                                | Notes  |
| EN IEC 55015/GB/T 17743/KN 15 <sup>(1)</sup> | Conducted emission Test & Radiated emission Test   |
| EN IEC 61000-3-2/GB 17625.1                  | Harmonic current emissions   |
| EN 61000-3-3                                 | Voltage fluctuations & flicker   |
| EMS Standards                                | Notes  |
| EN 61000-4-2                                 | Electrostatic Discharge (ESD): 8 kV air discharge, 4 kV contact discharge                    |
| EN 61000-4-3                                 | Radio-Frequency Electromagnetic Field Susceptibility Test-RS                                 |
| EN 61000-4-4                                 | Electrical Fast Transient / Burst-EFT  |
| EN 61000-4-5                                 | Surge Immunity Test: AC Power Line: Differential Mode 6 kV, Common Mode 10 kV <sup>(2)</sup> |

## Safety & EMC Compliance (Continued)

| EMS Standards | Notes   |
|---------------|---|
| EN 61000-4-6  | Conducted Radio Frequency Disturbances Test-CS                      |
| EN 61000-4-8  | Power Frequency Magnetic Field Test                                 |
| EN 61000-4-11 | Voltage Dips  |
| EN 61547      | Electromagnetic Immunity Requirements Applies To Lighting Equipment |

**Note:** (1) This LED driver meets the EMI specifications above, but EMI performance of a luminaire that contains it depends also on the other devices connected to the driver and on the fixture itself.

(2) To perform electric strength (hi-pot) testing, the "GDT ground disconnect" (nut and metal lock sheet) on the driver end-cap should be removed temporarily to prevent the internal gas discharge tube from conducting (as allowed by IEC 60598-1 Clause 10.2). After testing is completed, these items must be reinstalled to restore line-to-earth surge protection and secure the end cap.

## Lifetime vs. Case Temperature

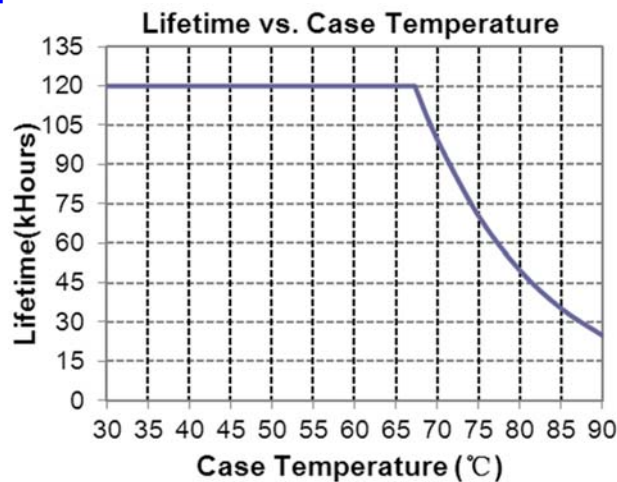

## Inrush Current Waveform

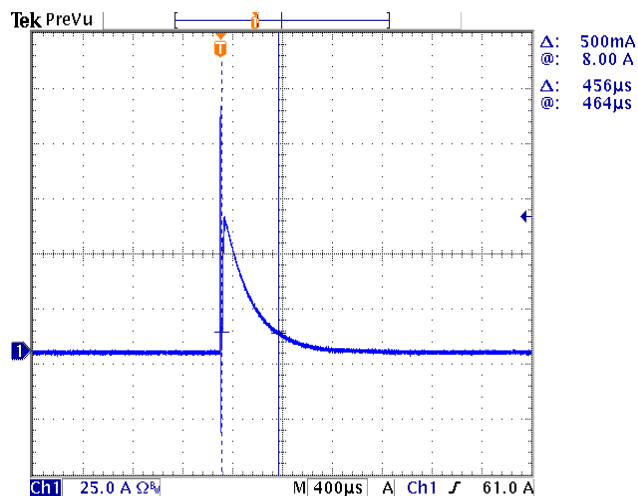



## Efficiency vs. Load

*EUG-075S070DV* ( $I_o=450mA$ )  
Efficiency vs. Output Voltage

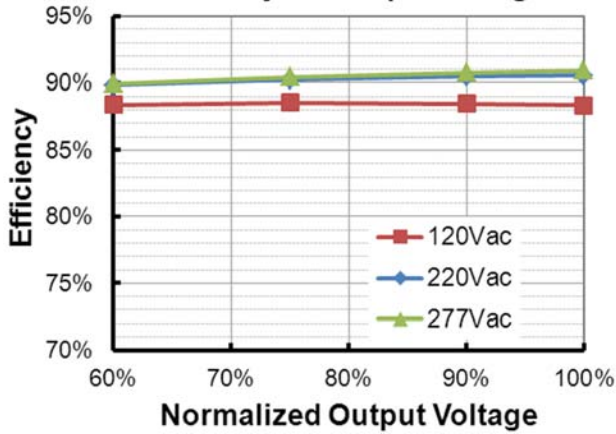

*EUG-075S070DV* ( $I_o=700mA$ )  
Efficiency vs. Output Voltage

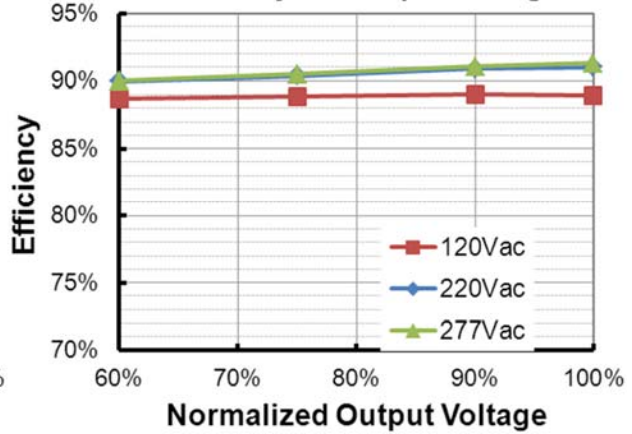

*EUG-075S105DV* ( $I_o=700mA$ )  
Efficiency vs. Output Voltage

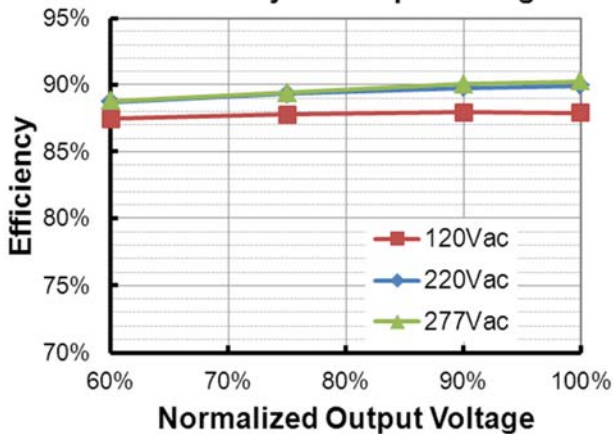

*EUG-075S105DV* ( $I_o=1050mA$ )  
Efficiency vs. Output Voltage

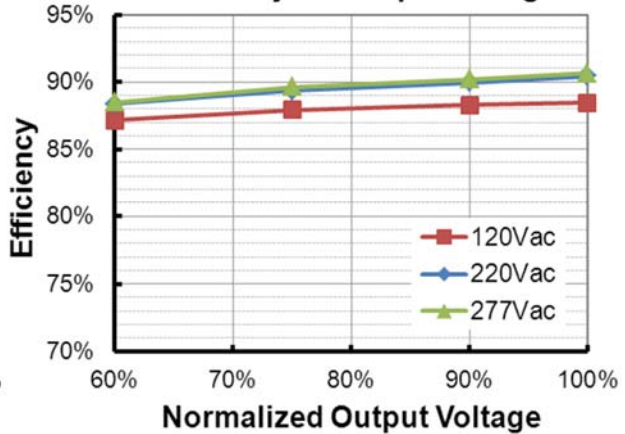

*EUG-075S175DV* ( $I_o=1190mA$ )  
Efficiency vs. Output Voltage

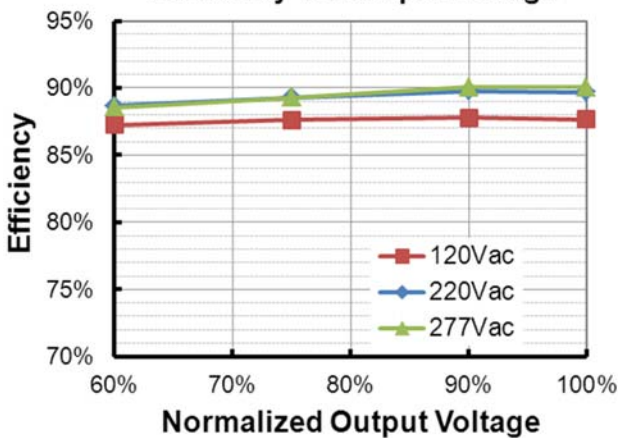

*EUG-075S175DV* ( $I_o=1750mA$ )  
Efficiency vs. Output Voltage

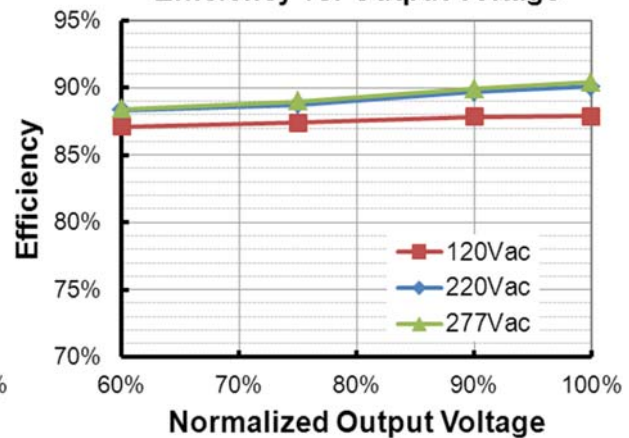

*EUG-075S280DV*( $I_o=1920mA$ )  
**Efficiency vs. Output Voltage**

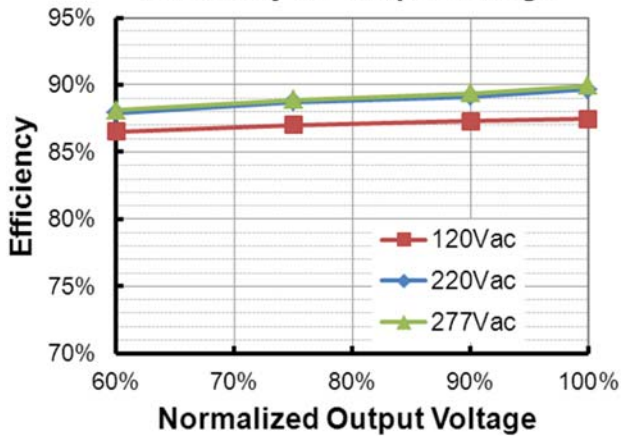

*EUG-075S280DV*( $I_o=2800mA$ )  
**Efficiency vs. Output Voltage**

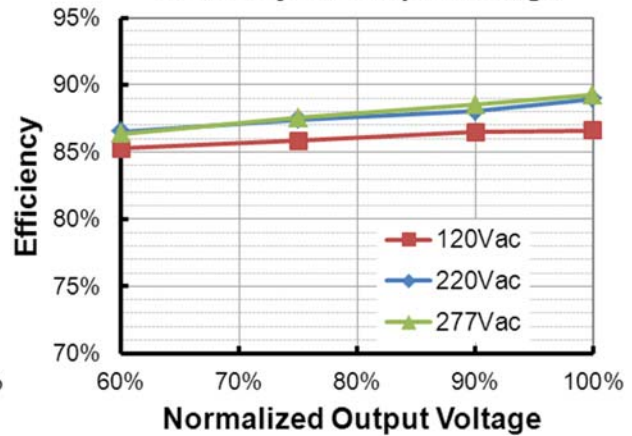

## Power Factor

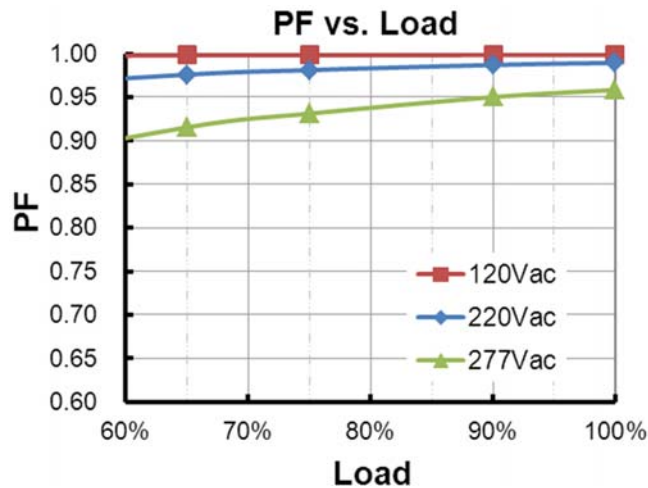

## Total Harmonic Distortion

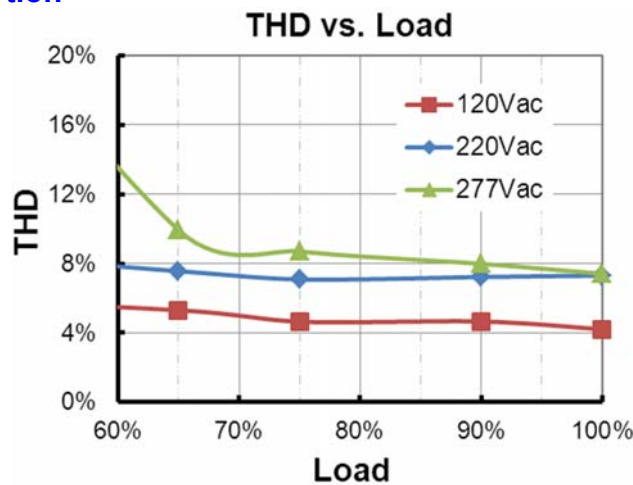



## Protection Functions

| Parameter                   | Notes  |
|-----------------------------|--|
| Over Temperature Protection | Decreases output current, returning to normal after over temperature is removed.   |
| Short Circuit Protection    | Auto Recovery. No damage will occur when any output is short circuited. The output shall return to normal when the fault condition is removed. |
| Over Voltage Protection     | Limits output voltage at no load and in case the normal voltage limit fails.   |

## Dimming

### ● 0-5V Dimming

The recommended implementation of the dimming control is provided below.

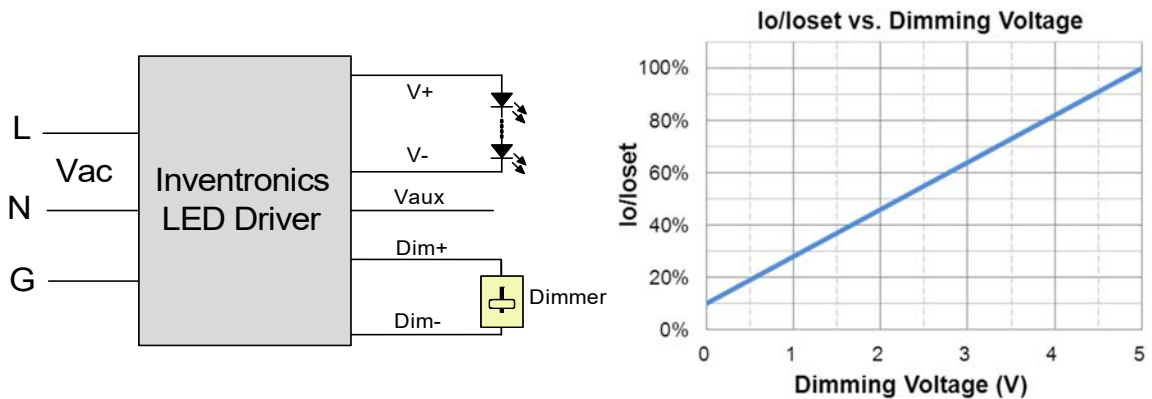

**Implementation 1: Positive logic**

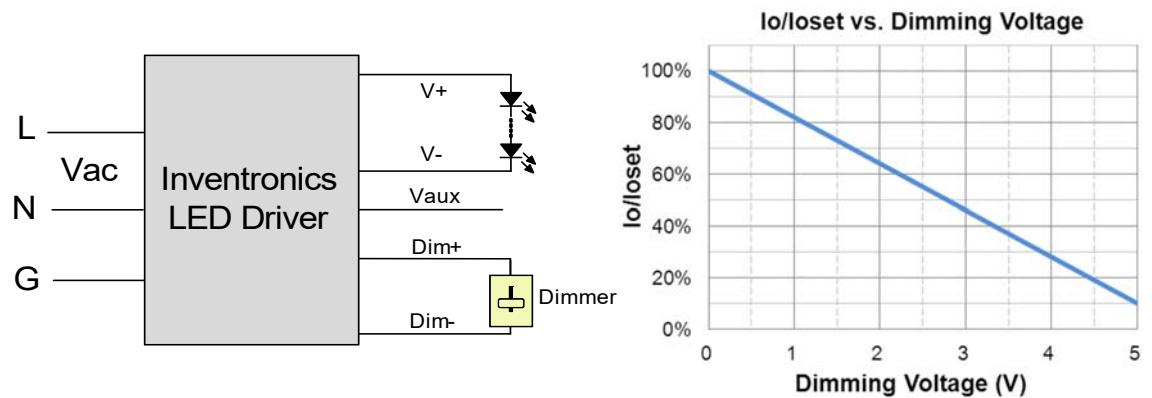

**Implementation 2: Negative logic**

### Notes:

1. Do NOT connect Dim- to the output V- or V+, otherwise the driver will not work properly.
2. The dimmer can also be replaced by an active 0-5V voltage source signal or passive components like zener.
3. When 0-5V negative logic dimming mode and Dim+ is open, the driver will output maximum current.

## ● 0-10V Dimming

The recommended implementation of the dimming control is provided below.

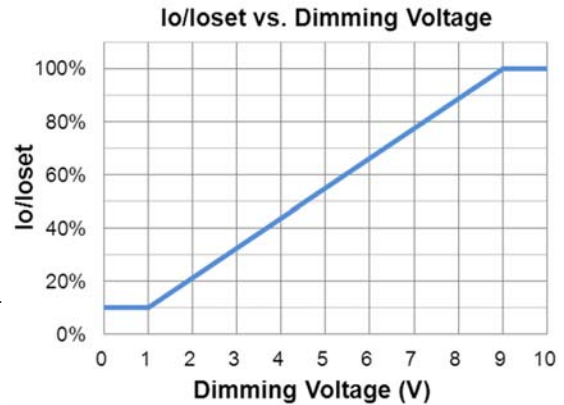
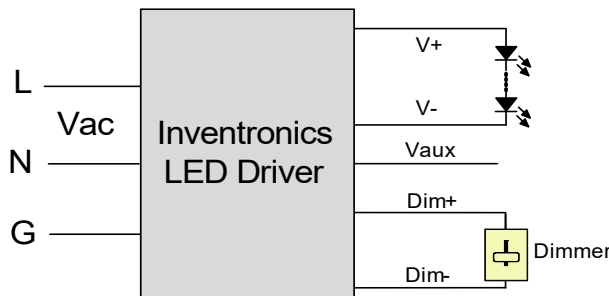

**Implementation 3: Positive logic**

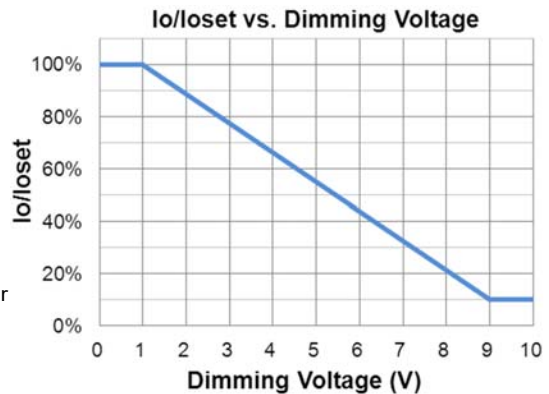
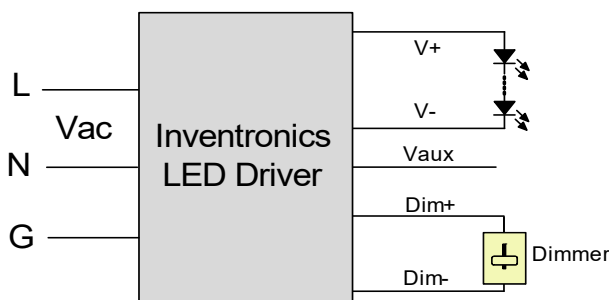

**Implementation 4: Negative logic**

### Notes:

1. Do NOT connect Dim- to the output V- or V+, otherwise the driver will not work properly.
2. The dimmer can also be replaced by an active 0-10V voltage source signal or passive components like zener.
3. When 0-10V negative logic dimming mode and Dim+ is open, the driver will output minimum current.

## ● PWM Dimming

The recommended implementation of the dimming control is provided below.

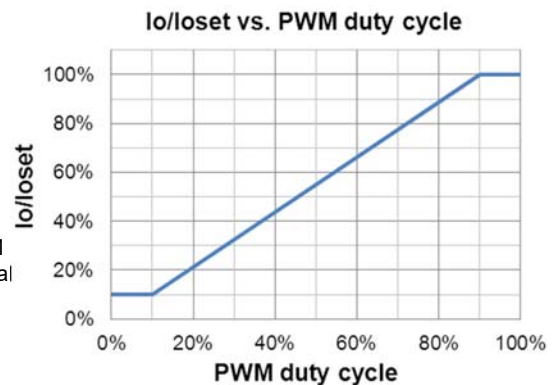
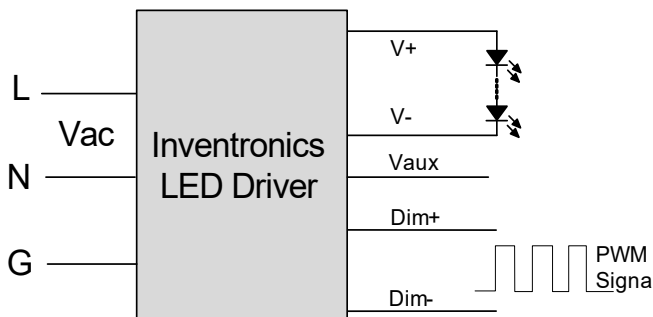

**Implementation 5: Positive logic**

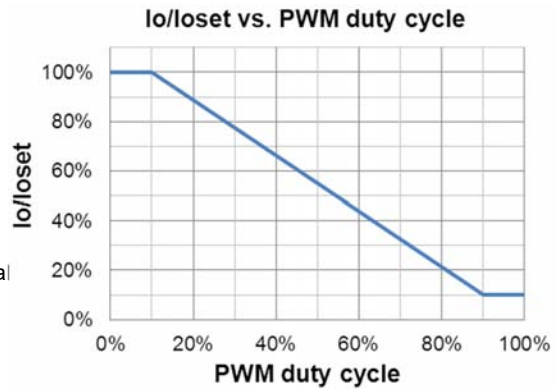
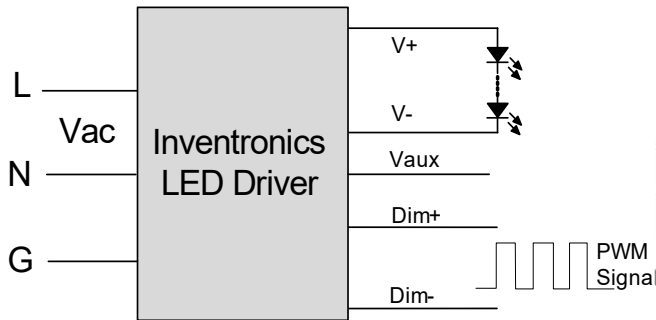

### Implementation 6: Negative logic

**Notes:**

1. Do NOT connect Dim- to the output V- or V+, otherwise the driver will not work properly.
2. When PWM negative logic dimming mode and Dim+ is open, the driver will output minimum current.

### ● Time Dimming

Set the timing curve by pulling the sliders.

## Programming Connection Diagram

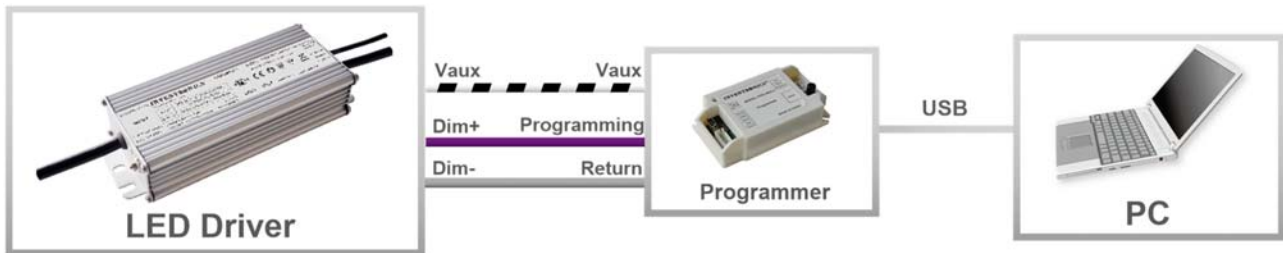

**Note:** The driver does not need to be powered on during the programming process.

- Please refer to [PRG-MUL2](#) (Programmer) datasheet for details

## Mechanical Outline

EUG-075SxxxDV

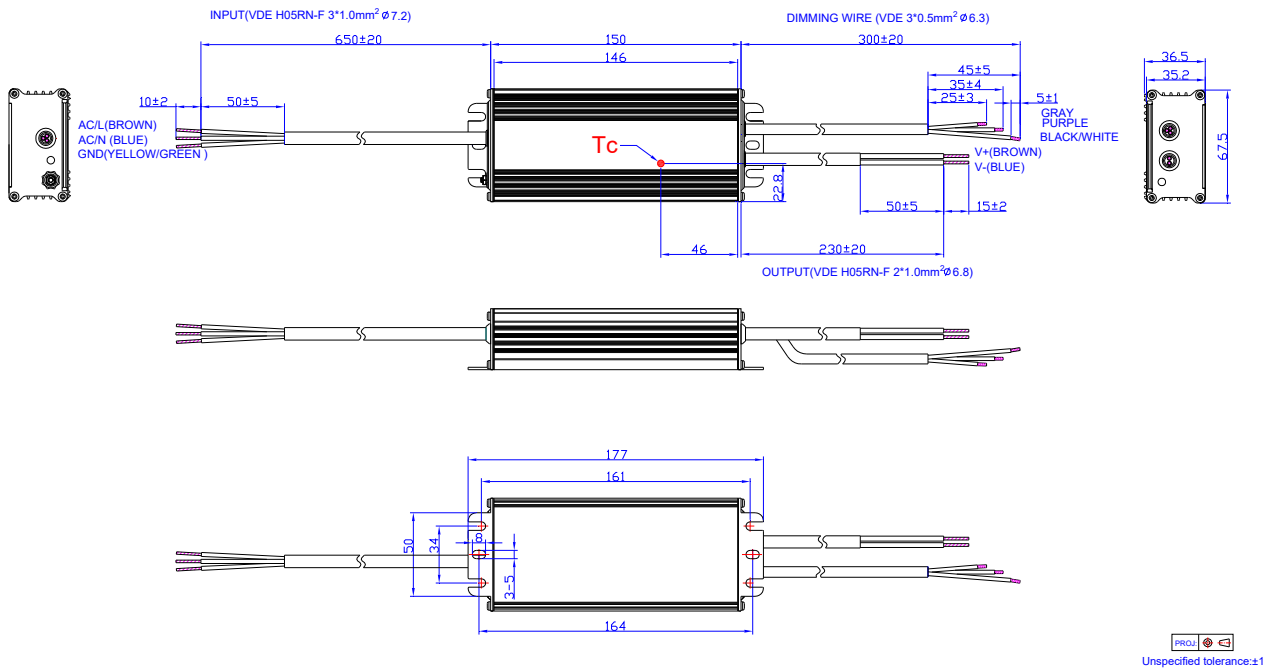

Unspecified tolerance: ±1

EUG-075SxxxDV-3000

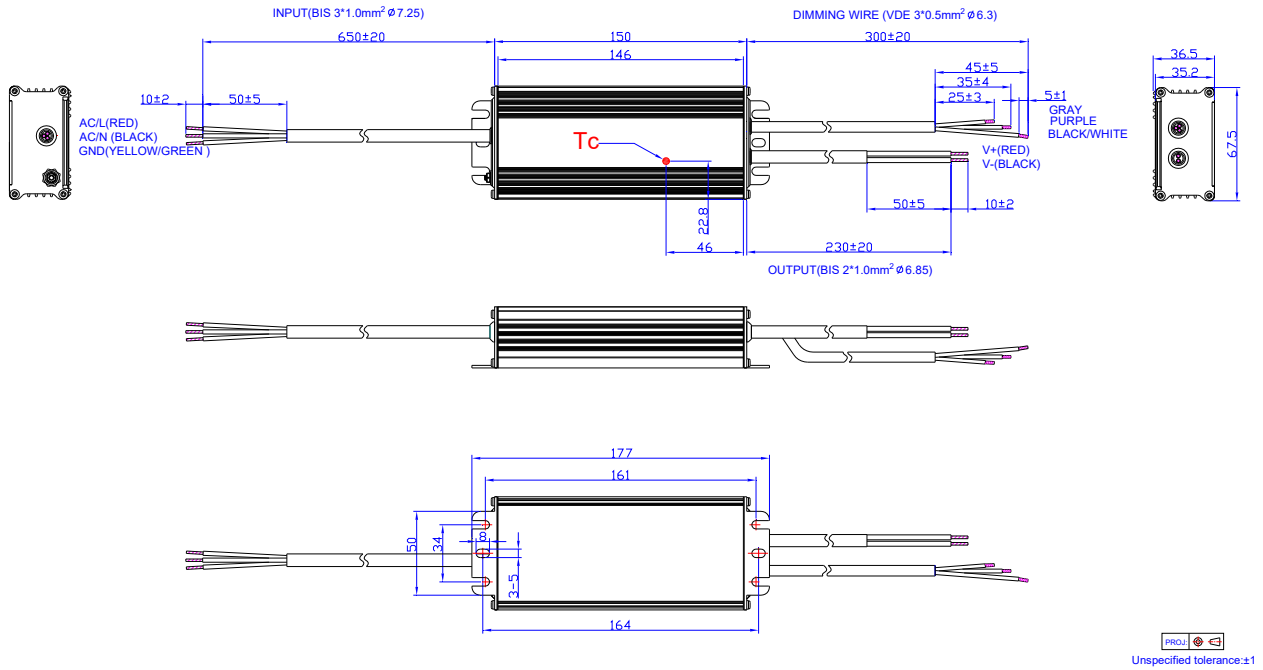

## RoHS Compliance

Our products comply with reference to RoHS Directive (EU) 2015/863 amending 2011/65/EU, calling for the elimination of lead and other hazardous substances from electronic products.

## Revision History

| Change Date            | Rev.        | Description of Change                        |                                  |                 |
|------------------------|-------------|--|----------------------------------|-----------------|
|                        |             | Item   | From                             | To              |
| 2015-12-28             | A           | Datasheets Release                           | /                                | /               |
| 2016-04-12             | B           | General Specifications                       | Net Weight                       | Added           |
|                        |             | General Specifications                       | With mounting ear                | Added           |
|                        |             | Safety &EMC Compliance                       | /                                | Updated         |
|                        |             | Mechanical Outline                           | /                                | Updated         |
| 2017-07-26             | C           | Models                                       | Notes                            | Updated         |
|                        |             | Input Specifications                         | PF/THD                           | Updated         |
|                        |             | Output Specifications                        | Temperature Coefficient of loset | Updated         |
|                        |             | General Specifications                       | Efficiency at 277 Vac input      | Updated         |
|                        |             | Mechanical Outline                           | /                                | Updated         |
|                        |             | Safety &EMC Compliance                       | /                                | Updated         |
| 2017-10-25             | D           | Features                                     | 7 Years Warranty                 | Added           |
|                        |             | Operating Case Temperature for Warranty Tc_w | /                                | Updated         |
| 2020-03-18             | E           | CCC Logo                                     | /                                | Updated         |
|                        |             | KCC Logo                                     | /                                | Added           |
|                        |             | Global Mark Logo                             | /                                | Added           |
|                        |             | Independent Logo                             | /                                | Added           |
|                        |             | Features                                     | 6kV line-line, 10kV line-earth   | DM 6kV, CM 10kV |
|                        |             | Features                                     | Waterproof (IP67)                | IP67            |
|                        |             | Features                                     | Suitable for Independent Use     | Deleted         |
|                        |             | Description                                  | Application environment          | Updated         |
|                        |             | Models                                       | Notes(5)                         | Added           |
|                        |             | Safety &EMC Compliance                       | ENEC                             | Added           |
|                        |             | Safety &EMC Compliance                       | TUV                              | Added           |
|                        |             | Safety &EMC Compliance                       | CB                               | Added           |
|                        |             | Safety &EMC Compliance                       | CCC                              | Added           |
|                        |             | Safety &EMC Compliance                       | PSE                              | Added           |
| Safety &EMC Compliance | BIS         | Added  |                                  |                 |
| Safety &EMC Compliance | Global Mark | Added  |                                  |                 |



## Revision History (Continued)

| Change Date | Rev. | Description of Change          |                         |  |
|-------------|------|--------------------------------|-------------------------|--|
|             |      | Item                           | From                    | To                                     |
| 2020-03-18  | E    | Safety &EMC Compliance         | EN 55015 <sup>(1)</sup> | EN 55015/GB 17743/KN 15 <sup>(1)</sup> |
|             |      | Safety &EMC Compliance         | EN 61000-3-2            | EN 61000-3-2/GB 17625.1                |
|             |      | Safety &EMC Compliance         | EN 61000-4-5            | Updated                                |
|             |      | Dimming                        | /                       | Updated                                |
|             |      | Programming Connection Diagram | EUG-075SxxxDV-3000      | Added                                  |
|             |      | Mechanical Outline             | EUG-075SxxxDV-3000      | Added                                  |
|             |      | RoHS Compliance                | /                       | Updated                                |
|             |      | Format                         | Page footer             | Updated                                |
| 2023-08-28  | F    | Product Photograph             | /                       | Updated                                |
|             |      | TUV/PSE/global-mark logo       | /                       | Deleted                                |
|             |      | SAA logo                       | /                       | Added                                  |
|             |      | Safety &EMC Compliance         | /                       | Updated                                |
|             |      | Programming Connection Diagram | /                       | Updated                                |