

Features

- Ultra High Efficiency (Up to 93%)
- Full Power at Wide Output Current Range (Constant Power)
- 0-5V/0-10V/PWM/Timer Dimmable
- Input Surge Protection: DM 6kV, CM 10kV
- All-Around Protection: OVP, SCP, OTP
- IP67
- SELV Output
- 7 Years Warranty



Description

The EUG-096SxxxDV series is a 96W, constant-current, programmable LED driver that operates from 90-305 Vac input with excellent power factor. It is created for many lighting applications including low bay, tunnel and street lights. The high efficiency of these drivers and compact metal case enables them to run cooler, significantly improving reliability and extending product life. To ensure trouble-free operation, protection is provided against input surge, output over voltage, short circuit, and over temperature.

Models

Adjustable Output Current Range	Full-Power Current Range (1)	Default Output Current	Input Voltage Range(2)	Output Voltage Range	Max. Output Power	Typical Efficiency (3)	Typical Power Factor		Model Number
							120Vac	220Vac	
45-700mA	450-700mA	530 mA	90 ~ 305 Vac 100 ~ 250 Vdc	74~213Vdc	96 W	92.0%	0.99	0.96	EUG-096S070DV
70-1050mA	700-1050mA	700 mA	90 ~ 305 Vac 100 ~ 250 Vdc	48~137Vdc	96 W	93.0%	0.99	0.96	EUG-096S105DV
140-2100mA	1400-2100mA	2100 mA	90 ~ 305 Vac 100 ~ 250 Vdc	24 ~ 69Vdc	96 W	92.0%	0.99	0.96	EUG-096S210DV ⁽⁴⁾
245-3500mA	2450-3500mA	2800 mA	90 ~ 305 Vac 100 ~ 250 Vdc	14 ~ 39Vdc	96 W	91.0%	0.99	0.96	EUG-096S350DV ⁽⁴⁾

- Notes:** (1) Output current range with constant power at 96W
 (2) Certified input voltage range: 100-240Vac or 100-250Vdc (except CCC, PSE, KS and BIS).
 (3) Measured at 100% load and 220Vac input (see below "General Specifications" for details).
 (4) SELV Output.

I-V Operation Area

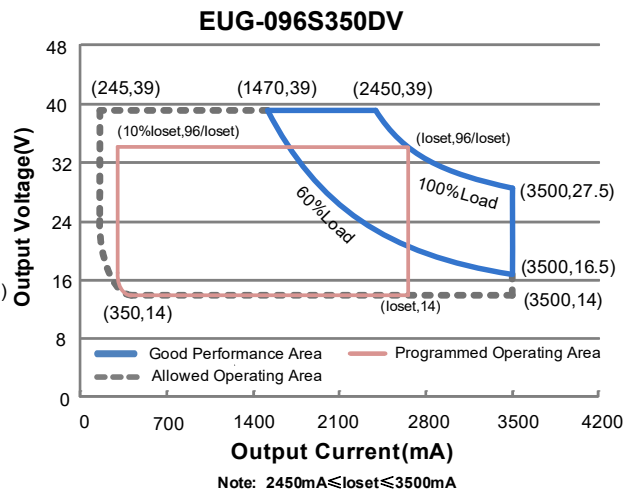
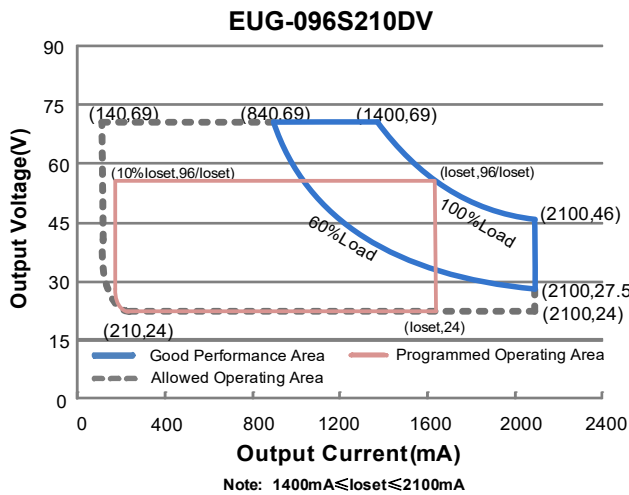
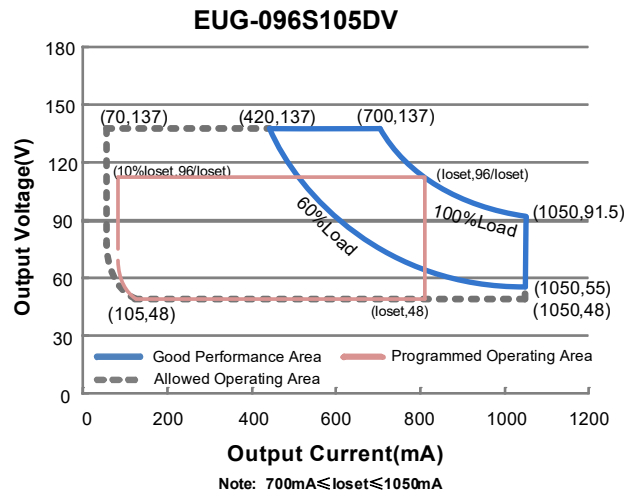
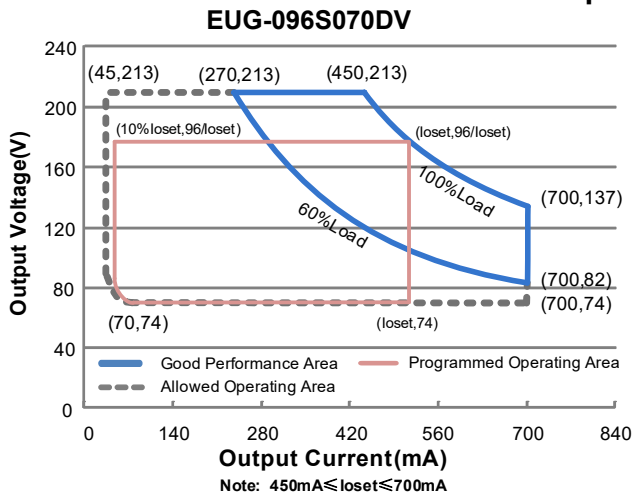

Input Specifications

Parameter	Min.	Typ.	Max.	Notes
Input AC Voltage	90 Vac	-	305 Vac	
Input DC Voltage	100 Vdc	-	250 Vdc	
Input Frequency	47 Hz	-	63 Hz	
Leakage Current	-	-	0.70 mA	IEC 60598-1; 240Vac/ 60Hz
Input AC Current	-	-	1.32 A	Measured at 100% load and 100 Vac input.
	-	-	0.60 A	Measured at 100% load and 220 Vac input.
Inrush Current(I ² t)	-	-	1.65 A ² s	At 220Vac input, 25°C cold start, duration=760 μs, 10%I _{pk} -10%I _{pk} . See Inrush Current Waveform for the details.

Input Specifications

Parameter	Min.	Typ.	Max.	Notes
PF	0.9	-	-	At 100-240Vac, 50-60Hz, 60%-100% Load (58-96W)
THD	-	-	20%	
THD	-	-	10%	At 220-240Vac, 50-60Hz, 75%-100% Load (72-96W)

Output Specifications

Parameter	Min.	Typ.	Max.	Notes
Output Current Tolerance	-5%loset	-	5%loset	At 100% load condition
Output Current Setting(loset) Range				
EUG-096S070DV	45 mA	-	700 mA	
EUG-096S105DV	70 mA	-	1050 mA	
EUG-096S210DV	140 mA	-	2100 mA	
EUG-096S350DV	245 mA	-	3500 mA	
Output Current Setting Range with Constant Power				
EUG-096S070DV	450 mA	-	700 mA	
EUG-096S105DV	700 mA	-	1050 mA	
EUG-096S210DV	1400 mA	-	2100 mA	
EUG-096S350DV	2450 mA	-	3500 mA	
Total Output Current Ripple (pk-pk)	-	5%lomax	10%lomax	At 100% load condition, 20 MHz BW
Output Current Ripple at < 200 Hz (pk-pk)	-	2%lomax	-	At 100% load condition. Only this component of ripple is associated with visible flicker.
Startup Overshoot Current	-	-	10%lomax	At 100% load condition
No Load Output Voltage				
EUG-096S070DV	-	-	280 V	
EUG-096S105DV	-	-	180 V	
EUG-096S210DV	-	-	90 V	
EUG-096S350DV	-	-	50 V	
Line Regulation	-	-	±0.5%	Measured at 100% load
Load Regulation	-	-	±1.5%	
Turn-on Delay Time	-	-	1.0 s	Measured at 120Vac input, 60%-100% Load.
	-	-	0.5 s	Measured at 220Vac input, 60%-100% Load.
Temperature Coefficient of loset	-	0.03%/°C	-	Case temperature = 0°C ~Tc max
12V Auxiliary Output Voltage	10.8 V	12 V	13.2 V	
12V Auxiliary Output Source Current	0 mA	-	20 mA	Return terminal is "Dim"

General Specifications

Parameter	Min.	Typ.	Max.	Notes
Efficiency at 120 Vac input: EUG-096S070DV				
Io= 450mA	87.0%	90.0%	-	
Io= 700mA	86.0%	89.0%	-	
EUG-096S105DV				Measured at 100% load and steady-state temperature in 25°C ambient; (Efficiency will be about 2.0% lower if measured immediately after startup.)
Io= 700mA	88.5%	91.5%	-	
Io=1050mA	87.0%	90.0%	-	
EUG-096S210DV				
Io=1400mA	87.0%	90.0%	-	
Io=2100mA	87.0%	90.0%	-	
EUG-096S350DV				
Io=2450mA	86.0%	89.0%	-	
Io=3500mA	85.5%	88.5%	-	
Efficiency at 220 Vac input: EUG-096S070DV				
Io= 450mA	90.0%	92.0%	-	
Io= 700mA	89.0%	91.0%	-	
EUG-096S105DV				Measured at 100% load and steady-state temperature in 25°C ambient; (Efficiency will be about 2.0% lower if measured immediately after startup.)
Io= 700mA	91.0%	93.0%	-	
Io=1050mA	89.0%	91.0%	-	
EUG-096S210DV				
Io=1400mA	89.5%	91.5%	-	
Io=2100mA	90.0%	92.0%	-	
EUG-096S350DV				
Io=2450mA	89.0%	91.0%	-	
Io=3500mA	88.0%	90.0%	-	
Efficiency at 277 Vac input: EUG-096S070DV				
Io= 450mA	90.5%	92.5%	-	
Io= 700mA	89.0%	91.0%	-	
EUG-096S105DV				Measured at 100% load and steady-state temperature in 25°C ambient; (Efficiency will be about 2.0% lower if measured immediately after startup.)
Io= 700mA	91.5%	93.5%	-	
Io=1050mA	89.5%	91.5%	-	
EUG-096S210DV				
Io=1400mA	90.0%	92.0%	-	
Io=2100mA	90.5%	92.5%	-	
EUG-096S350DV				
Io=2450mA	89.5%	91.5%	-	
Io=3500mA	88.5%	90.5%	-	
MTBF	-	339,000 Hours	-	Measured at 220Vac input, 80%Load and 25°C ambient temperature (MIL-HDBK-217F)
Lifetime	-	98,000 Hours	-	Measured at 220Vac input, 80%Load and 70°C case temperature; See lifetime vs. Tc curve for the details
Operating Case Temperature for Safety Tc_s	-40°C	-	+90°C	
Operating Case Temperature for Warranty Tc_w	-40°C	-	+75°C	Case temperature for 7 years warranty. Please see Inventronics Warranty Statement for complete details.
Storage Temperature	-40°C	-	+85°C	Humidity: 5%RH to 95%RH
Dimensions				With mounting ear
Inches (L × W × H)	6.85 × 2.66 × 1.44			7.92 × 2.66 × 1.44
Millimeters (L × W × H)	174 × 67.5 × 36.5			201 × 67.5 × 36.5
Net Weight	-	890 g	-	

Dimming Specifications

Parameter		Min.	Typ.	Max.	Notes
Absolute Maximum Voltage on the Vdim (+) Pin		-20 V	-	20 V	
Source Current on Vdim (+)Pin		200 uA	300 uA	450 uA	Vdim(+) = 0 V
Dimming Output Range	EUG-096S070DV EUG-096S105DV EUG-096S210DV EUG-096S350DV	10%I _{load}	-	I _{load}	450mA ≤ I _{load} ≤ 700mA 700mA ≤ I _{load} ≤ 1050mA 1400mA ≤ I _{load} ≤ 2100mA 2450mA ≤ I _{load} ≤ 3500mA
	EUG-096S070DV EUG-096S105DV EUG-096S210DV EUG-096S350DV	45 mA 70 mA 140 mA 245 mA	-	I _{load}	45mA ≤ I _{load} < 450mA 70mA ≤ I _{load} < 700mA 140mA ≤ I _{load} < 1400mA 245mA ≤ I _{load} < 2450mA
Recommended Dimming Range for 0-5V		0 V	-	5 V	Dimming mode set to 0-5V in Inventronics programming software .
Recommended Dimming Range for 0-10V		0 V	-	10 V	Default 0-10V dimming mode with positive logic.
PWM_in High Level		3 V	-	10 V	Dimming mode set to PWM in.Inventronics programming software
PWM_in Low Level		-0.3 V	-	0.6 V	
PWM_in Frequency Range		200 Hz	-	2 KHz	
PWM_in Duty Cycle		1%	-	99%	

Safety & EMC Compliance

Safety Category	Standard
ENEC & CE	EN 61347-1, EN61347-2-13
CB	IEC 61347-1, IEC 61347-2-13
CCC	GB 19510.1, GB 19510.14
KS	KS C 7655
BIS	IS 15885(Part2/Sec13)
global-mark	AS/NZS 61347.1, AS/NZS 61347.2.13
EMI Standards	Notes
EN IEC 55015/GB/T 17743 ⁽¹⁾	Conducted emission Test &Radiated emission Test
EN IEC 61000-3-2/GB 17625.1	Harmonic current emissions
EN 61000-3-3	Voltage fluctuations & flicker
EMS Standards	Notes
EN 61000-4-2	Electrostatic Discharge (ESD): 8 kV air discharge, 4 kV contact discharge
EN 61000-4-3	Radio-Frequency Electromagnetic Field Susceptibility Test-RS
EN 61000-4-4	Electrical Fast Transient / Burst-EFT

Safety & EMC Compliance (Continued)

EMS Standards	Notes
EN 61000-4-5	Surge Immunity Test: AC Power Line: Differential Mode 6 kV, Common Mode 10 kV ⁽²⁾
EN 61000-4-6	Conducted Radio Frequency Disturbances Test-CS
EN 61000-4-8	Power Frequency Magnetic Field Test
EN 61000-4-11	Voltage Dips
EN 61547	Electromagnetic Immunity Requirements Applies To Lighting Equipment

- Note:** (1) This LED driver meets the EMI specifications above, but EMI performance of a luminaire that contains it depends also on the other devices connected to the driver and on the fixture itself.
 (2) To perform electric strength (hi-pot) testing, the “GDT ground disconnect” (nut and metal lock sheet) on the driver end-cap should be removed temporarily to prevent the internal gas discharge tube from conducting (as allowed by IEC 60598-1 Clause 10.2). After testing is completed, these items must be reinstalled to restore line-to-earth surge protection and secure the end cap.

Lifetime vs. Case Temperature

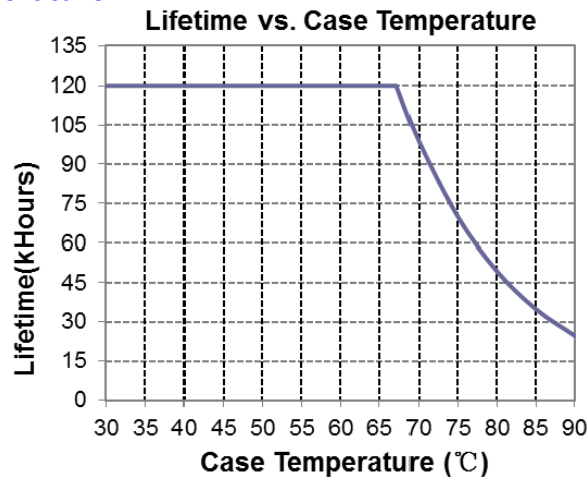

Inrush Current Waveform

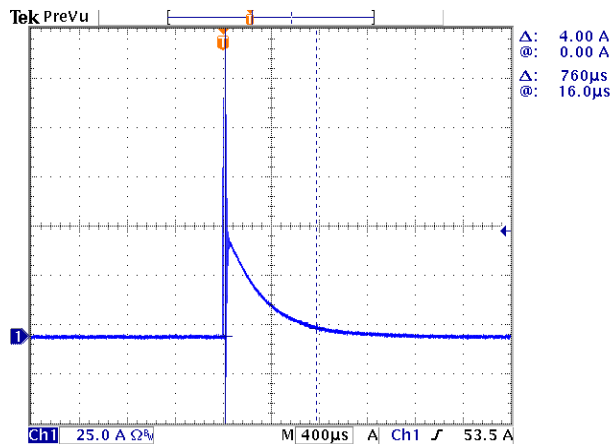

Efficiency vs. Load

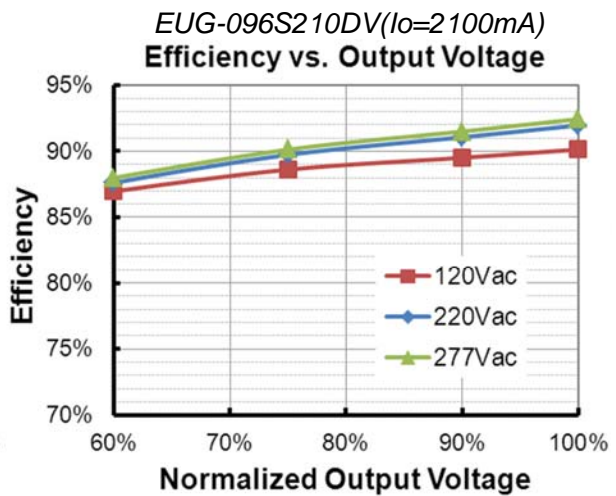
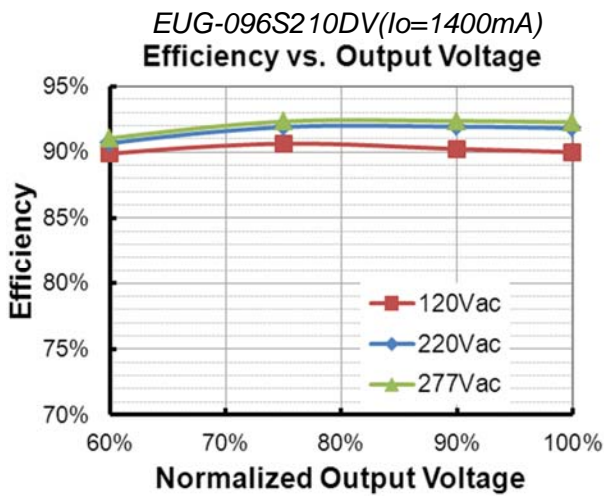
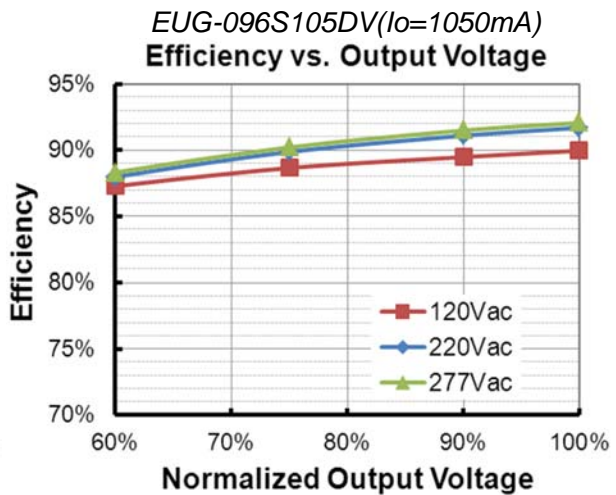
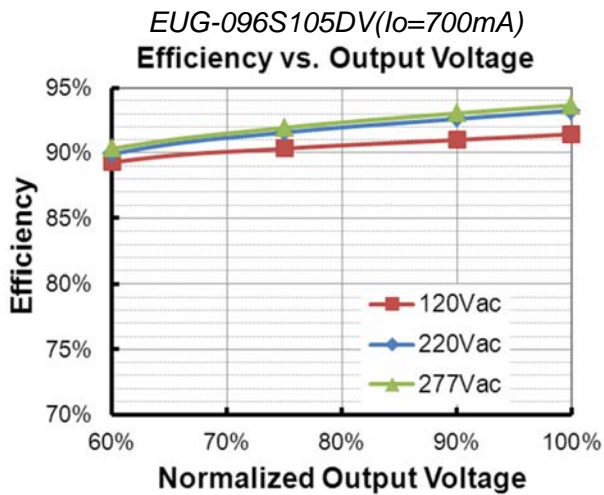
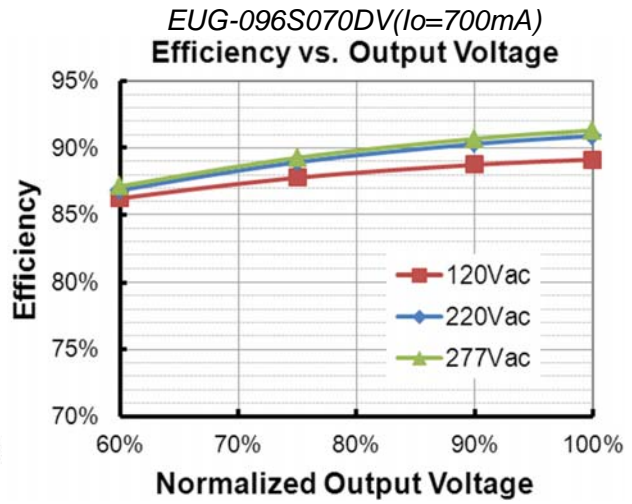
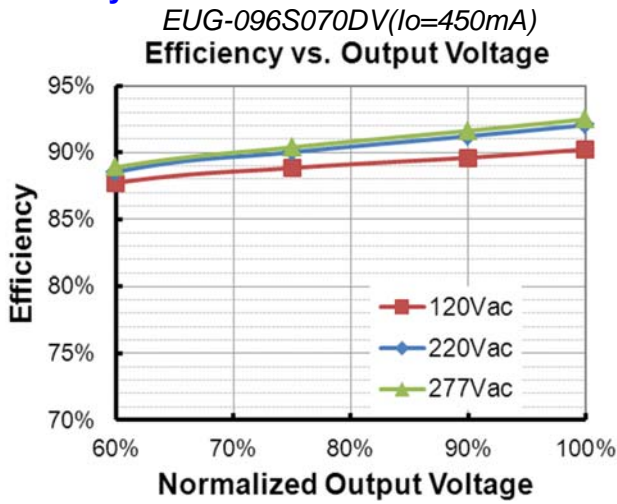

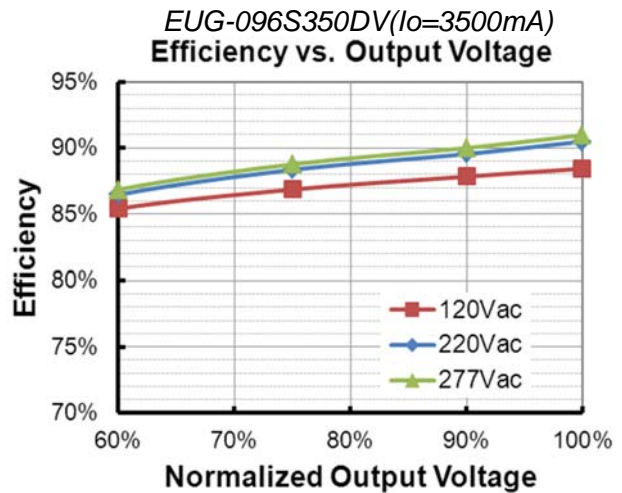
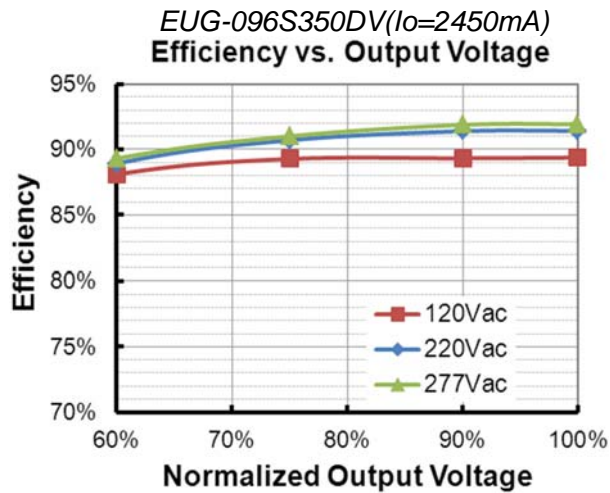

Power Factor

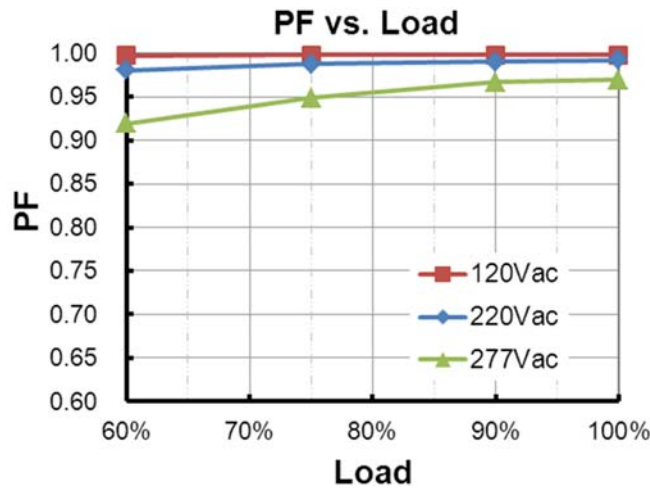

Total Harmonic Distortion

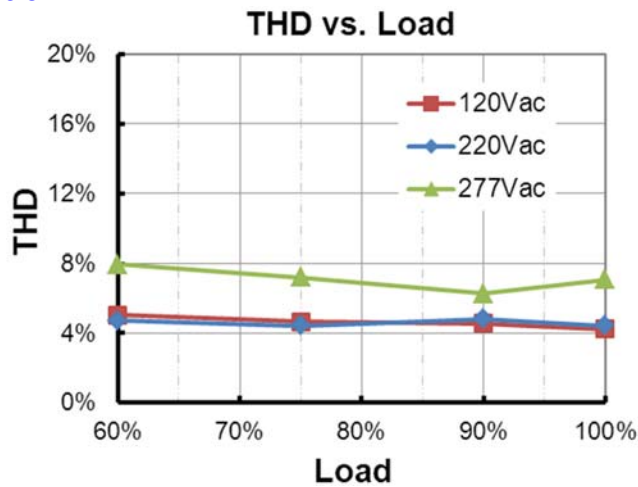

Protection Functions

Parameter	Notes
Over Temperature Protection	Decreases output current, returning to normal after over temperature is removed.
Short Circuit Protection	Auto Recovery. No damage will occur when any output is short circuited. The output shall return to normal when the fault condition is removed.
Over Voltage Protection	Limits output voltage at no load and in case the normal voltage limit fails.

Dimming

● 0-5V Dimming

The recommended implementation of the dimming control is provided below.

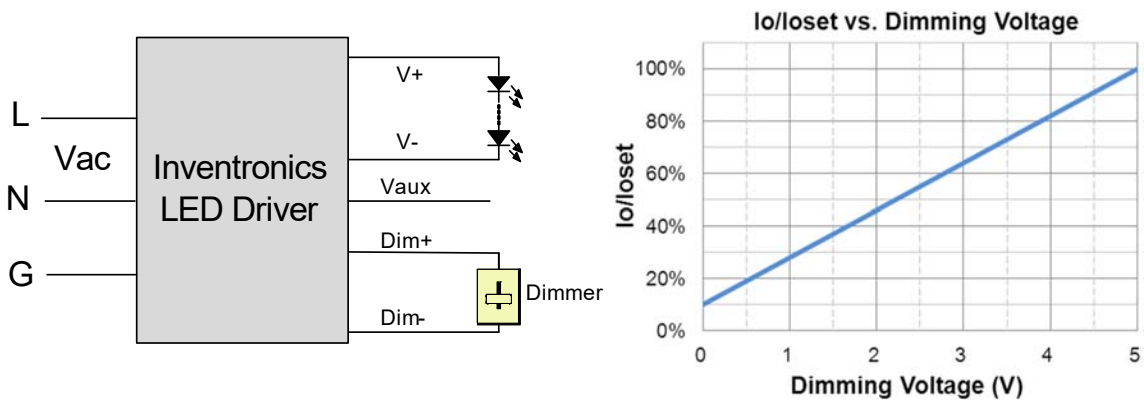

Implementation 1: Positive logic

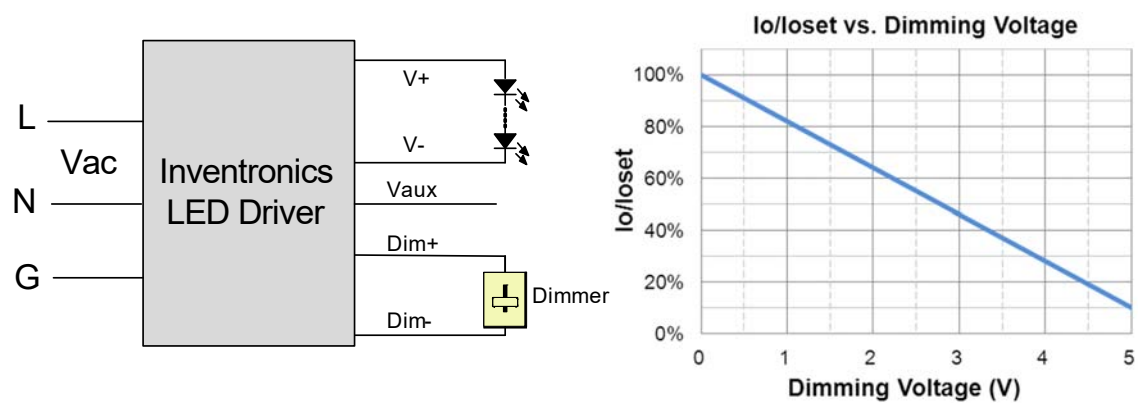

Implementation 2: Negative logic

Notes:

1. Do NOT connect Dim- to the output V- or V+, otherwise the driver will not work properly.
2. The dimmer can also be replaced by an active 0-5V voltage source signal or passive components like zener.
3. When 0-5V negative logic dimming mode and Dim+ is open, the driver will output maximum current.

● 0-10V Dimming

The recommended implementation of the dimming control is provided below.

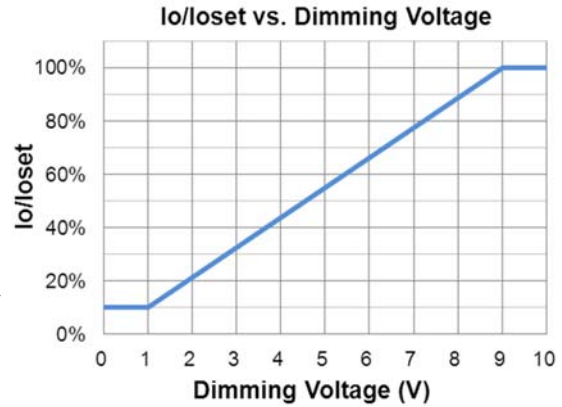
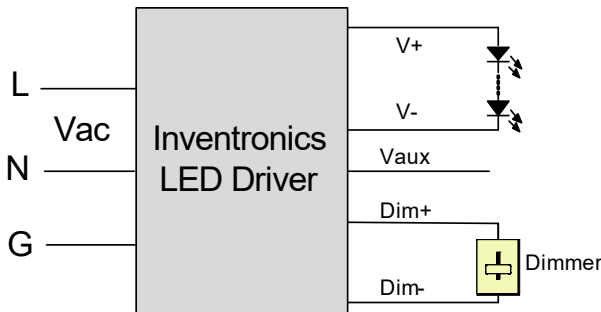

Implementation 3: Positive logic

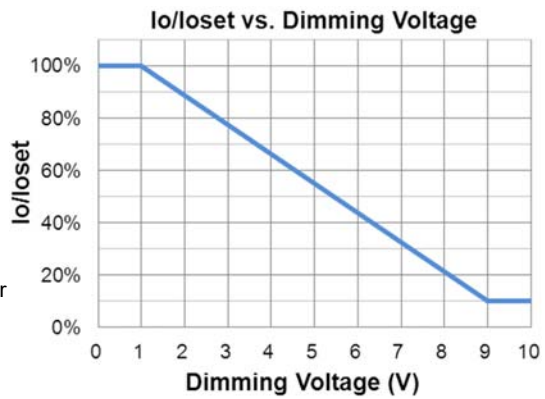
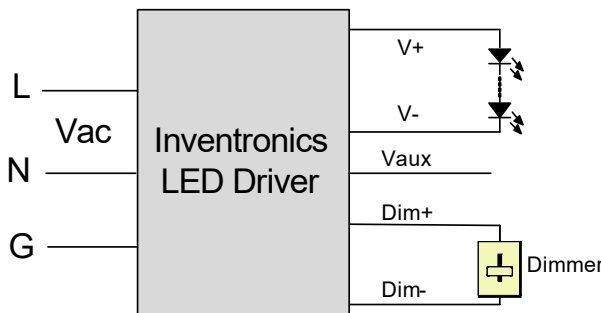

Implementation 4: Negative logic

Notes:

1. Do NOT connect Dim- to the output V- or V+, otherwise the driver will not work properly.
2. The dimmer can also be replaced by an active 0-10V voltage source signal or passive components like zener.
3. When 0-10V negative logic dimming mode and Dim+ is open, the driver will output minimum current.

● PWM Dimming

The recommended implementation of the dimming control is provided below.

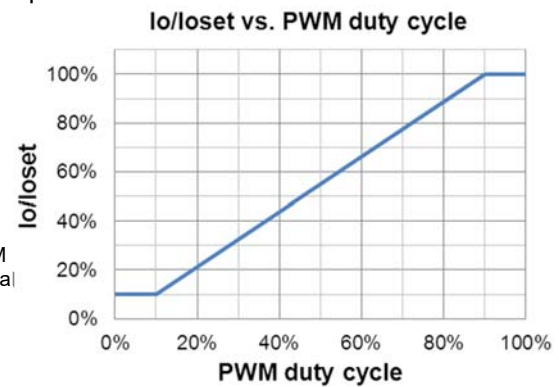
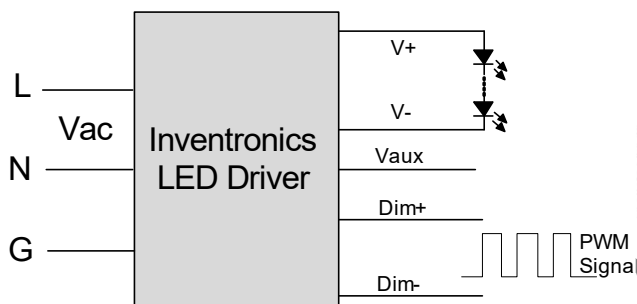

Implementation 5: Positive logic

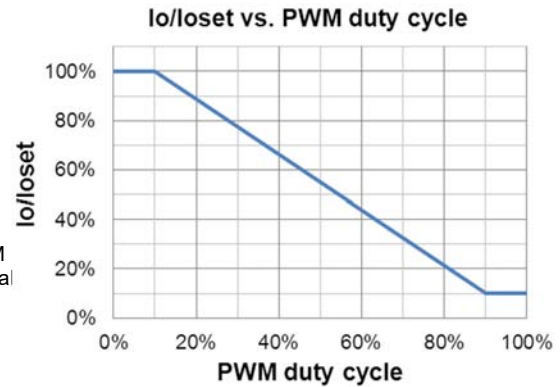
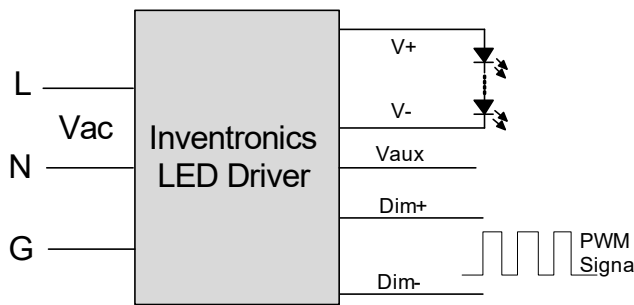

Implementation 6: Negative logic

Notes:

1. Do NOT connect Dim- to the output V- or V+, otherwise the driver will not work properly.
2. When PWM negative logic dimming mode and Dim+ is open, the driver will output minimum current.

● Time Dimming

Set the timing curve by pulling the sliders.

Programming Connection Diagram

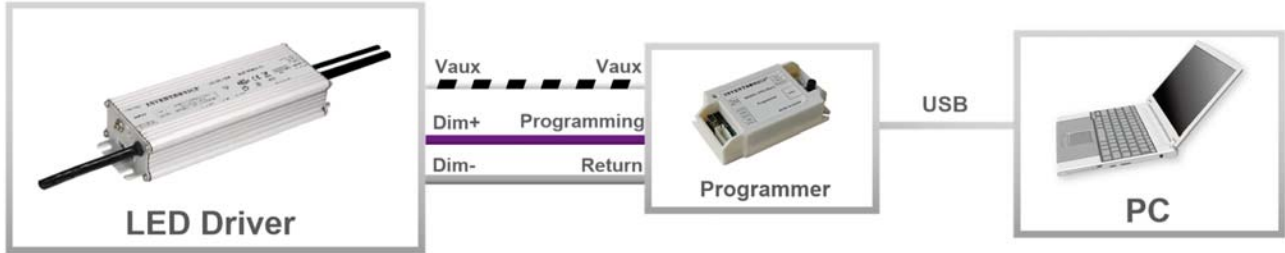

Note: The driver does not need to be powered on during the programming process.

- Please refer to [PRG-MUL2 \(Programmer\) datasheet](#) for details.

Mechanical Outline

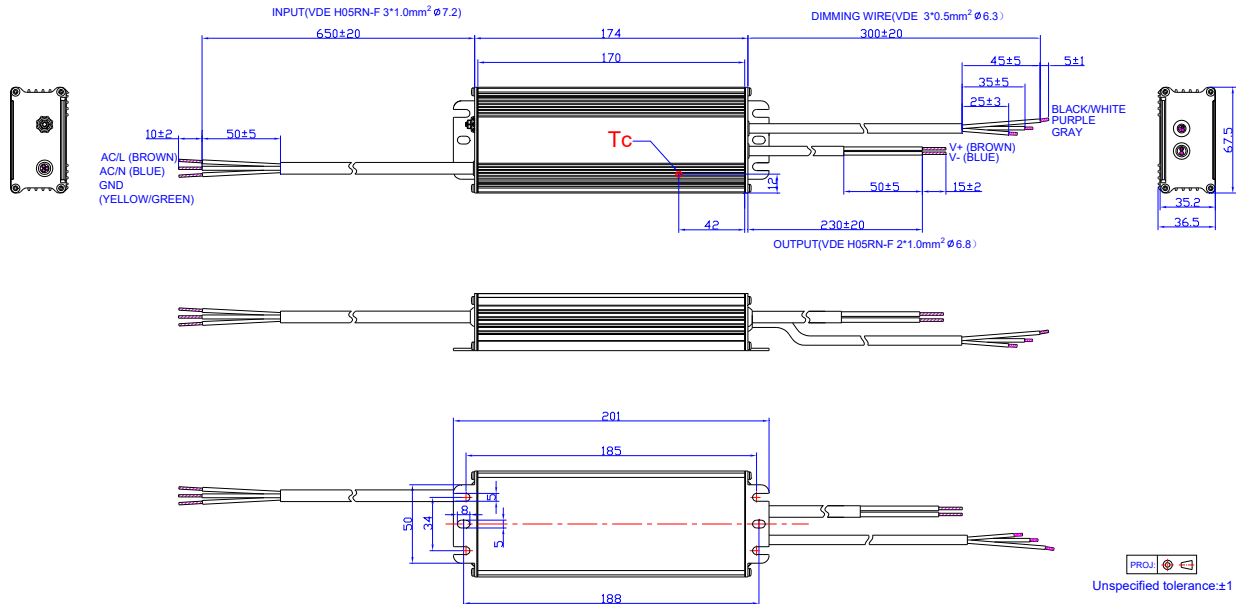

RoHS Compliance

Our products comply with reference to RoHS Directive (EU) 2015/863 amending 2011/65/EU, calling for the elimination of lead and other hazardous substances from electronic products.

Revision History

Change Date	Rev.	Description of Change		
		Item	From	To
2015-07-08	A	Datasheets Release	/	/
2016-02-29	B	TUV, BIS	/	Added
		EUG-096S070DV	/	Added
		Net Weight	/	Updated
		Safety & EMC Compliance	KS	Added
		Mechanical Outline	/	Updated
2017-07-27	C	Models	Notes	Updated
		Input Specifications	PF/THD	Updated
		Output Specifications	Temperature Coefficient of loset	Updated
		General Specifications	Dimensions	Updated
		Safety & EMC Compliance	/	Updated
		Mechanical Outline	/	Updated
2017-10-26	D	Features	7 Years Warranty	Added
		Operating Case Temperature for Warranty Tc_w	/	Updated
2018-01-31	E	Description	/	Updated
		General Specifications	Lifetime	Updated
		General Specifications	Operating Case Temperature for Warranty Tc_w	Updated
		Lifetime vs. Case Temperature	/	Updated
2023-08-15	F	TUV/PSE logo	/	Deleted
		global-mark logo	/	Added
		CCC logo	/	Updated
		Product photograph	/	Updated
		Safety & EMC Compliance	/	Updated
		Programming Connection Diagram	/	Updated