

## Features

- 0 -10V Dimmable (Compatible with Passive Dimmers)
- 5% Minimum Dimming Level
- Two Channels of Constant Current Output
- High Efficiency (Up to 87%)
- Active Power Factor Correction (0.95 Typical)
- Waterproof (IP54)
- All-Around Protection: SCP, OVP, OTP
- Independent Class II and SELV



## Description

The LUC-042DxxxDDM(SDM) Series operates from a 90 ~ 305 Vac input range. They are designed to be highly efficient and highly reliable. Features include lightning protection, short circuit protection, over voltage protection and over temperature protection.

## Model List

Output Current	Input Voltage Range(1)	Output Voltage Range	Max. Output Power	Efficiency (2)	Power Factor (2)	Model Number
450 mA	90 ~ 305 Vac	27~ 47 Vdc	42 W	87 %	0.95	LUC-042D045DDM(SDM)
520 mA	90 ~ 305 Vac	20~ 41 Vdc	42 W	86 %	0.95	LUC-042D052DDM(SDM)
560 mA	90 ~ 305 Vac	20~ 40 Vdc	45 W	86 %	0.95	LUC-042D056DDM(SDM)
700 mA	90 ~ 305 Vac	17~ 30 Vdc	42 W	85 %	0.95	LUC-042D070DDM(SDM)

**Notes:** (1) Certified input voltage range 100-240Vac;  
 (2) Measured at a 220 Vac input with a full load.

## Input Specifications

Parameter	Min.	Typ.	Max.	Notes
Input Voltage	90 Vac	-	305 Vac	
Input Frequency	47 Hz	-	63 Hz	
Leakage Current	-	-	0.5 mA	At 277Vac, 60Hz input
Input AC Current	-	-	0.46 A	Measured at full load and 120 Vac input
Inrush Current	-	-	50 A	At 220Vac input, 25°C cold start, duration=50 μs, 10%Ipk-10%Ipk.
Inrush Current(I <sup>2</sup> t)	-	-	0.042 A <sup>2</sup> s	
Power Factor	0.90	-	-	At 100Vac-277Vac, 75%load-100%load
THD	-	-	20%	

## Output Specifications

Parameter	Min.	Typ.	Max.	Notes
# of Output Channels	-	2	-	
Output Current Tolerance	-5%	-	5%	
Output Current Ripple	-	5%Io	10%Io	Full load condition; ripple frequency 140K
Startup Overshoot Current	-	-	10%	Full load condition

## Output Specifications (Continued)

Parameter	Min.	Typ.	Max.	Notes
Line Regulation	-	-	±1%	
Load Regulation	-	-	±3%	
Turn-on Delay Time	-	0.8 s	1.0 s	Measured at 120Vac input
Dimming Range (Io)	5%	-	100%	
Temperature coefficient	-	-	0.01%/°C	Case temperature = 0°C ~Tc max

**Note:** All specifications are typical at 25 °C unless stated otherwise;

## Protection Functions

Parameter	Min.	Typ.	Max.	Notes
No Load Voltage	Vomax	110% Vomax	130% Vomax	Vomax is the maximum operation output voltage
Short Circuit Protection	Latch mode. The power supply shall return to normal operation only after the power is turn-on again.			
Over Temperature Protection	Decrease output current mode. When the case temperature reaches 100±10°C, the output current decreases to 50%Io until the case temperature reaches 50°C.			

## General Specifications

Parameter	Min.	Typ.	Max.	Notes
Efficiency Io=450 mA Io=520 mA Io=560 mA Io=700 mA	85% 84% 84% 83%	86% 85% 85% 84%	- - - -	Measured at full load and 120 Vac input
Efficiency Io=450 mA Io=520 mA Io=560 mA Io=700 mA	86% 85% 85% 84%	87% 86% 86% 85%	- - - -	Measured at full load and 220 Vac input
Efficiency Io=450 mA Io=520 mA Io=560 mA Io=700 mA	86% 85% 85% 84%	87% 86% 86% 85%	- - - -	Measured at full load and 277 Vac input
No Load Power Dissipation	-	-	3 W	
MTBF	-	471,000 Hours	-	Measured at 120Vac input, 80%load and 25°C ambient temperature (MIL-HDBK-217F)
Life Time	-	87,900 Hours	-	Measured at 120Vac input, 80%load, Case temperature=60°C @ Tc point. See life time vs. Tc curve for the details
Case temperature	-	-	90°C	
Dimensions Inches (L × W × H) Millimeters (L × W × H)	8.39 × 1.71 × 1.20 213 × 43.5 × 30.5			
Net Weight		510 g		

**Note:** All specifications are typical at 25 °C unless stated otherwise.

## Environmental Specifications

Parameter	Min.	Typ.	Max.	Notes
Operating Temperature	-20 °C	-	+70 °C	Humidity: 10% RH to 100% RH. See Derating Curve for more details
Storage Temperature	-30 °C	-	+85 °C	Humidity: 5% RH to 100% RH

## Safety & EMC Compliance

Safety Category	Standard
CE	EN 61347-1, EN61347-2-13
PSE	J 61347-1(H20), J 61347-2-13(H21)
EMI Standards	Notes
EN 55015/CISPR15	Conducted Emission Test & Radiated Emission Test
EN 61000-3-2	Harmonic Current Emissions Class C
EN 61000-3-3	Voltage Fluctuations & Flicker
PSE	J 55015 (H20)
EMS Standards	Notes
EN 61000-4-2	Electrostatic Discharge (ESD): 8 kV air discharge, 4 kV contact discharge Level 3, Criteria A
EN 61000-4-3	Radio-Frequency Electromagnetic Field Susceptibility Test-RS Level 3, Criteria A
EN 61000-4-4	Electrical Fast Transient / Burst-EFT Level 3, Criteria A
EN 61000-4-5	Surge Immunity Test: AC Power Line: Line to Line 2 kV
EN 61000-4-6	Conducted Radio Frequency Disturbances Test-CS Level 3, Criteria A
EN 61000-4-8	Power Frequency Magnetic Field Test 3A/m , Criteria A
EN 61000-4-11	Voltage Dips Criteria B
EN 61547	Electromagnetic Immunity Requirements Applies to Lighting Equipment

## Derating Curve

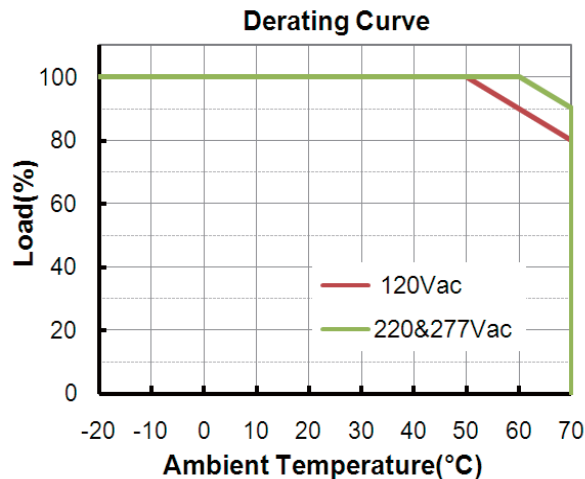

## Life Time vs. Case Temperature Curve

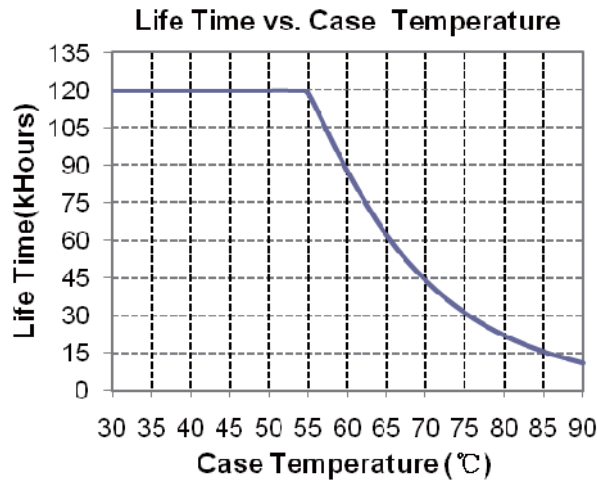

## Efficiency vs. Load

LUC-042D045DDM(SDM)

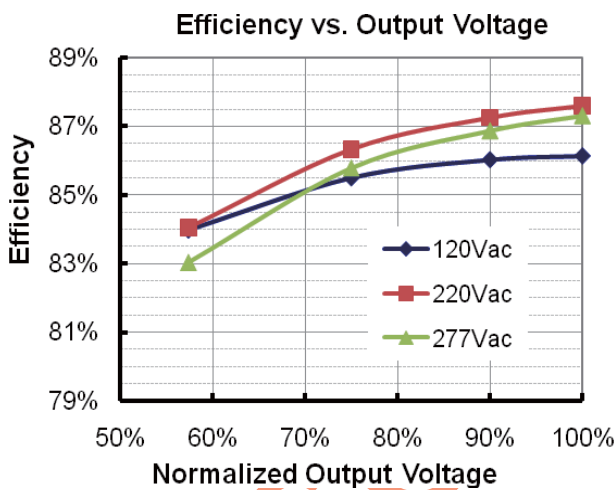

LUC-042D052DDM(SDM)

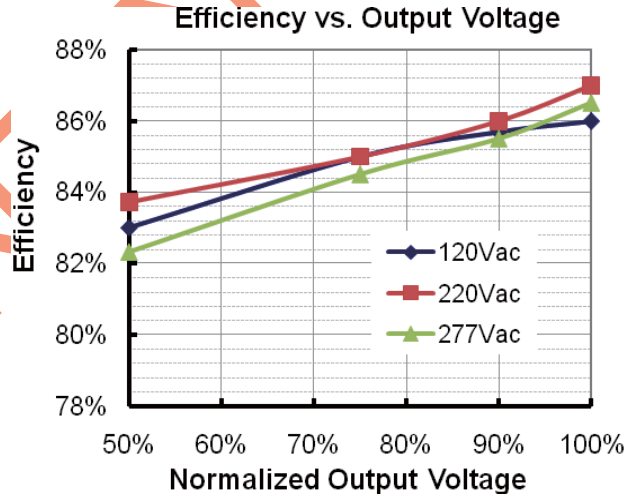

LUC-042D056DDM(SDM)

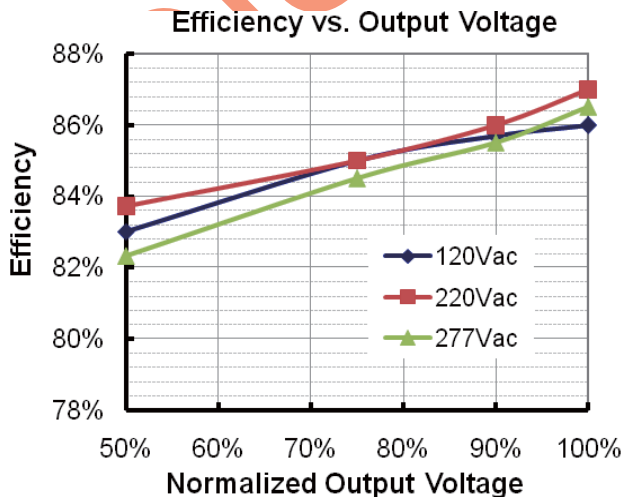

LUC-042D070DDM(SDM)

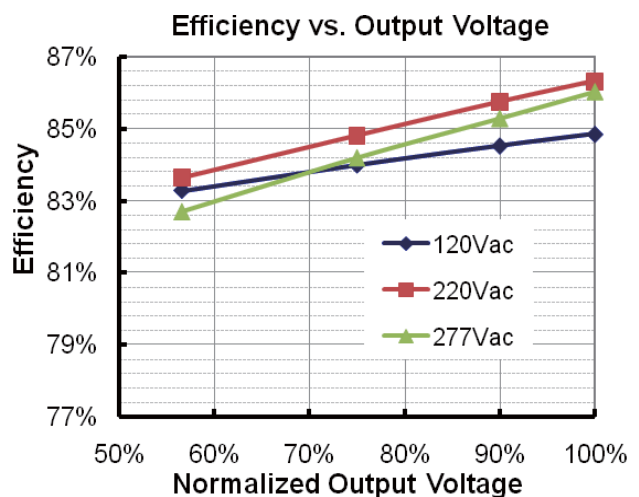

## Power Factor Characteristics

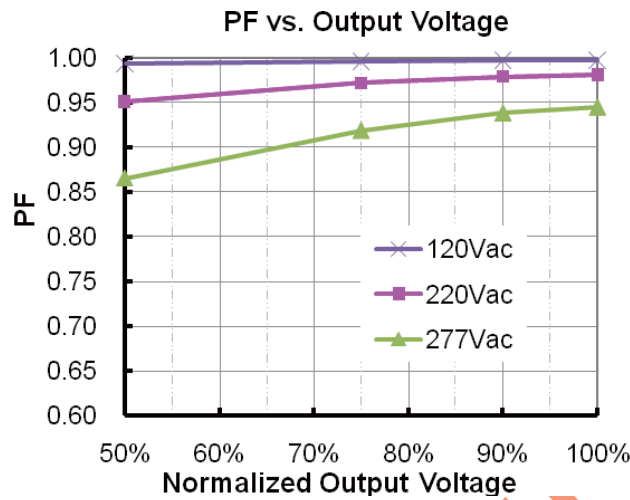

## Total Harmonic Distortion

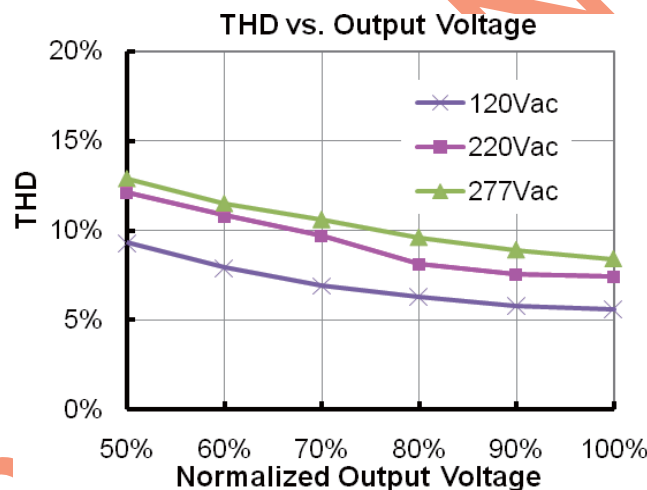

## Dimming Control (On secondary side)

Parameter	Min.	Typ.	Max.	Notes
12V output voltage	10.8 V	12.0 V	13.2 V	
12V output source current	0 mA	-	60 mA	
Absolute Maximum Voltage on the 0~10V Wire	-20 V	-	20 V	
0~10V Wire Current Sourcing Capability	100 uA	150 uA	200 uA	

The dimmer control is operated from an input signal of 0 – 10 Vdc. Recommended implementations are provided below.

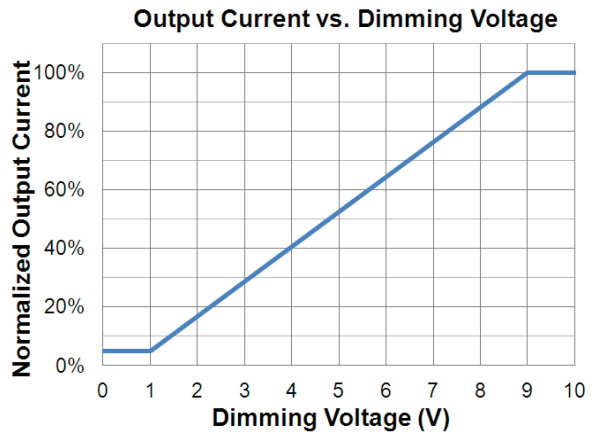
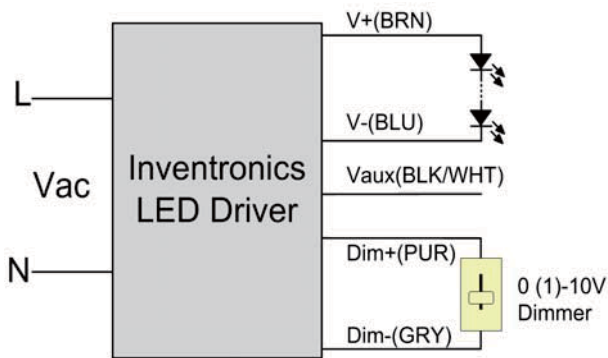

Implementation 1: DC Input

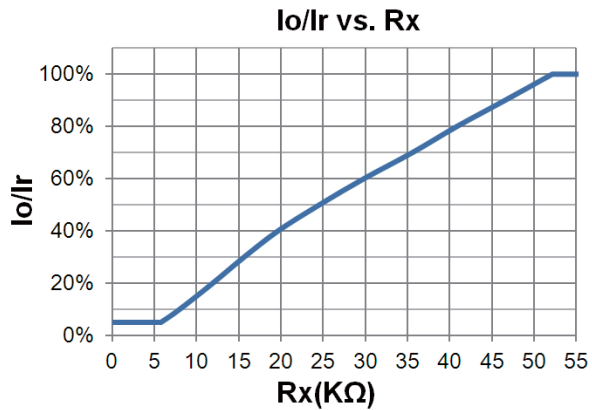
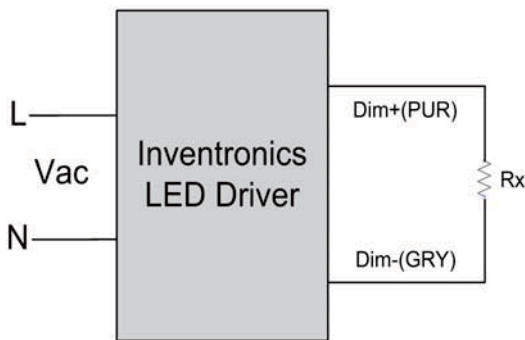

Implementation 2: External Resistor

**Notes:**

1. The dimming signal is allowed to be less than 1V, however, when it is between 0-1V, the output current is 5% $I_o$ .
2. Do not connect the dimming wires to the output; otherwise, the LED driver cannot work normally.
3. If 0-10V dimming is not used, Dim + can be either open or connected to Vaux.

DISCOM

## Mechanical Outline

### LUC-042DxxxDDM

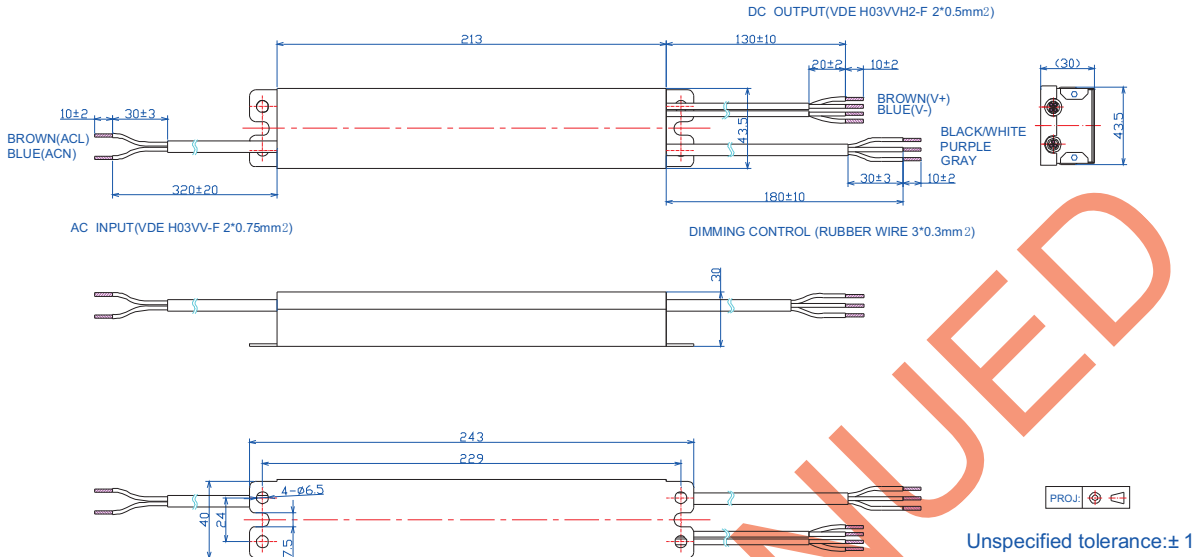

### LUC-042DxxxSDM

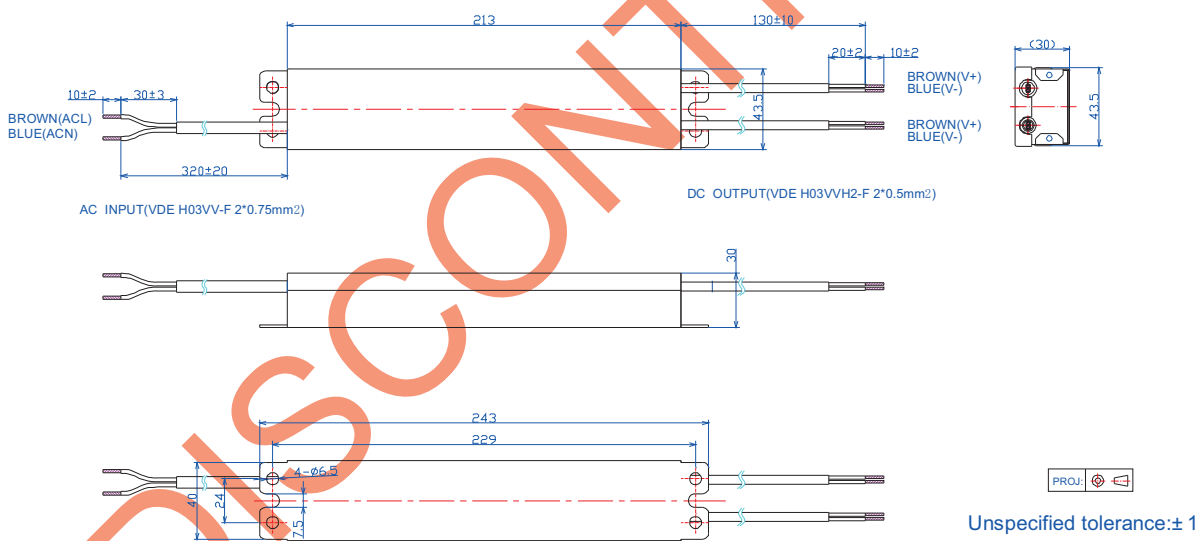

### Notes:

1. For the driver to operate properly, the load voltage must be maintained above the minimum voltage threshold.
2. The two brown wires (Vout positive) are connected internally; the two blue wires (Vout negative) are separated inside.
3. The Vout(+) wires are allowed to be connected together. But, the Vout(-) wires cannot be connected together or will become single channel output.

### RoHS Compliance

Our products comply with the European Directive 2011/65/EC, calling for the elimination of lead and other hazardous substances from electronic products.

## Revision History

Change Date	Rev.	Description of Change		
		Item	From	To
2012-01-17	A	Datasheets Released	/	/
2013-04-07	B	OTP description	/	Added
		The note of Output Current Ripple	/	Updated
		Notes of mechanical outline	/	Added
		EN 61000-4-5- Surge Immunity Test: AC Power Line:	Line to Line 1 kV	Line to Line 2 kV
2013-08-14	C	Io/Ir vs. Rx Curve	/	Added

DISCONTINUED