

Features

- 0 -10V Dimmable (Compatible with Passive Dimmers)
- 5% Minimum Dimming Level
- Three Channels of Constant Current Output
- High Efficiency (Up to 87%)
- Active Power Factor Correction (0.96 Typical)
- Waterproof (IP54)
- All-Around Protection: SCP, OTP, OVP
- Independent Class II and SELV



Description

The LUC-066TxxxDDM(SDM) Series operates from a 90 ~ 305 Vac/127~250 Vdc input range. They are designed to be highly efficient and highly reliable. Features include lightning protection, short circuit protection, over voltage protection and over temperature protection.

Model List

Output Current	Input Voltage Range(1)	Output Voltage Range	Max. Output Power	Efficiency (2)	Power Factor (2)	Model Number
450 mA	90 ~ 305 Vac 127~ 250 Vdc	25~ 49 Vdc	66 W	87 %	0.96	LUC-066T045DDM(SDM)
560 mA	90 ~ 305 Vac 127~ 250 Vdc	20~ 40 Vdc	66 W	86 %	0.96	LUC-066T056DDM(SDM)
700 mA	90 ~ 305 Vac 127~ 250 Vdc	16~ 32 Vdc	66 W	85 %	0.96	LUC-066T070DDM(SDM)

Notes: (1) Certified input voltage range 100-240Vac/127-250Vdc
 (2) Measured at 220 Vac input with full load

Input Specifications

Parameter	Min.	Typ.	Max.	Notes
Input Voltage	90 Vac	-	305 Vac	127~250 Vdc
Input Frequency	47 Hz	-	63 Hz	
Leakage Current	-	-	0.75 mA	At 277Vac, 60Hz input
Input AC Current	-	-	0.8 A	Measured at full load and 120 Vac input
Inrush Current	-	-	69 A	At 220Vac input Ta=25°C cold start, duration = 750 μs, 10%Ipk-10%Ipk.
Inrush Current(I ² t)	-	-	2 A ² s	
Power Factor	0.9	-	-	At 100Vac-277Vac, 75%load-100%load
THD	-	-	20%	

Output Specifications

Parameter	Min.	Typ.	Max.	Notes
# of Output Channel	-	3	-	
Output Current Tolerance	-5%	-	5%	At full load condition
Output Current Ripple	-	-	10%Io	At full load condition
Startup Overshoot Current	-	-	10%	At full load condition

Output Specifications (Continued)

Parameter	Min.	Typ.	Max.	Notes
Line Regulation	-	-	± 1%	
Load Regulation	-	-	± 4%	
Turn-on Delay Time	-	1.0 s	2.0 s	Measured at 120Vac input
	-	1.0 s	2.0 s	Measured at 220Vac input
Dimming Range (Io)	5%	-	100%	
Temperature Coefficient	-	-	0.03%/°C	Case temperature = 0°C ~Tc max

Note: All specifications are typical at 25 °C unless otherwise stated.

Protection Functions

Parameter	Min.	Typ.	Max.	Notes
No Load Voltage	Vomax	115% Vomax	130% Vomax	Vomax is the maximum operation output voltage
Short Circuit Protection	Latch mode. The power supply shall return to normal operation only after the power is turn-on again.			
Over Temperature Protection	Decrease output current mode. It will be back to normal condition after over temperature is removed.			

General Specifications

Parameter	Min.	Typ.	Max.	Notes
Efficiency Io=450 mA Io=560 mA Io=700 mA	84%	86%	-	Measured at full load and 120 Vac input It will be lower about 1%, if measured immediately after startup.
	83%	85%	-	
	82%	84%	-	
Efficiency Io=450 mA Io=560 mA Io=700 mA	85%	87%	-	Measured at full load and 220 Vac input It will be lower about 1%, if measured immediately after startup.
	84%	86%	-	
	83%	85%	-	
Efficiency Io=450 mA Io=560 mA Io=700 mA	85%	87%	-	Measured at full load and 277 Vac input It will be lower about 1%, if measured immediately after startup.
	84%	86%	-	
	83%	85%	-	
No Load Power Dissipation	-	-	3 W	
MTBF	-	304,000 Hours	-	Measured at 120Vac input, 80%load and 25°C ambient temperature (MIL-HDBK-217F)
Life Time	-	116,000 Hours	-	Measured at 120Vac input, 80%load, Case temperature = 60°C @ Tc point. See life time vs. Tc curve for the details
Case Temperature	-	-	90°C	
Dimensions Inches (L × W × H) Millimeters (L × W × H)	10.76 × 1.71 × 1.18 273.3 × 43.5 × 30			
Net Weight		600 g		

Note: All specifications are typical at 25 °C unless otherwise stated.

Environmental Specifications

Parameter	Min.	Typ.	Max.	Notes
Operating Ambient Temperature	-20°C	-	+70°C	Humidity: 10% RH to 90% RH; See Derating Curve for more details
Storage Temperature	-30°C	-	+85°C	Humidity: 5% RH to 90% RH

Safety & EMC Compliance

Safety Category	Standard
CE	EN 61347-1, EN61347-2-13
PSE	J 61347-1(H20), J 61347-2-13(H21)
EMI Standards	Notes
EN 55015/CISPR15	Conducted Emission Test & Radiated Emission Test
EN 61000-3-2	Harmonic Current Emissions Class C
EN 61000-3-3	Voltage Fluctuations & Flicker
PSE	J 55015 (H20)
EMS Standards	Notes
EN 61000-4-2	Electrostatic Discharge (ESD): 8 kV air discharge, 4 kV contact discharge
EN 61000-4-3	Radio-Frequency Electromagnetic Field Susceptibility Test
EN 61000-4-4	Electrical Fast Transient / Burst
EN 61000-4-5	Surge Immunity Test: AC Power Line: Line to Line 4 kV
EN 61000-4-6	Conducted Radio Frequency Disturbances Test
EN 61000-4-8	Power Frequency Magnetic Field Test 3A/m
EN 61000-4-11	Voltage Dips
EN 61547	Electromagnetic Immunity Requirements Applies to Lighting Equipment

Derating Curve

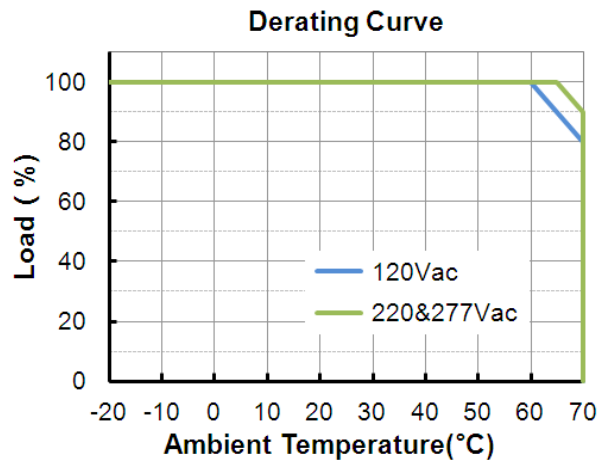

Life Time vs. Case Temperature Curve

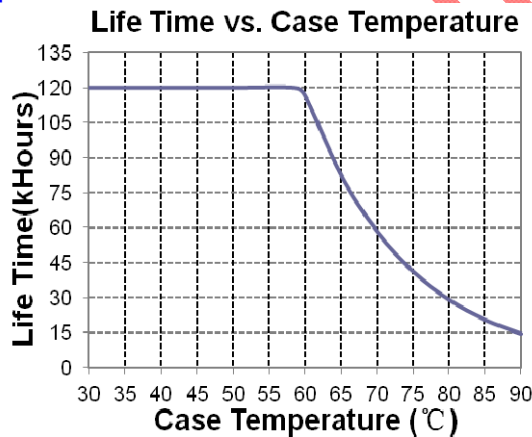

Efficiency vs. Load

LUC-066T045DDM(SDM)

Efficiency vs. Output Voltage

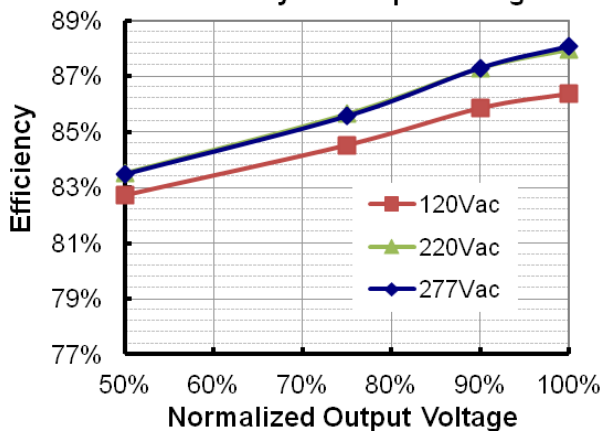

LUC-066T056DDM(SDM)

Efficiency vs. Output Voltage

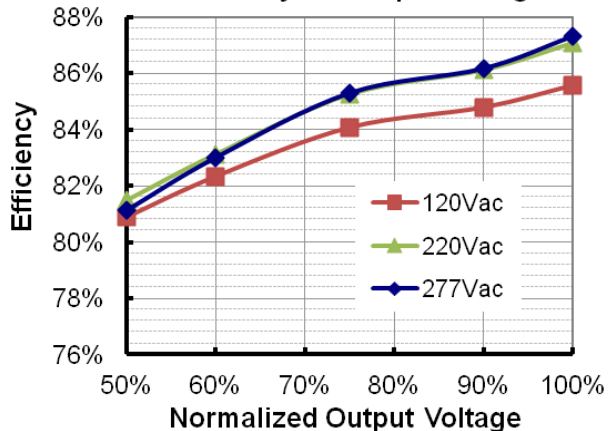

LUC-066T070DDM(SDM)

Efficiency vs. Output Voltage

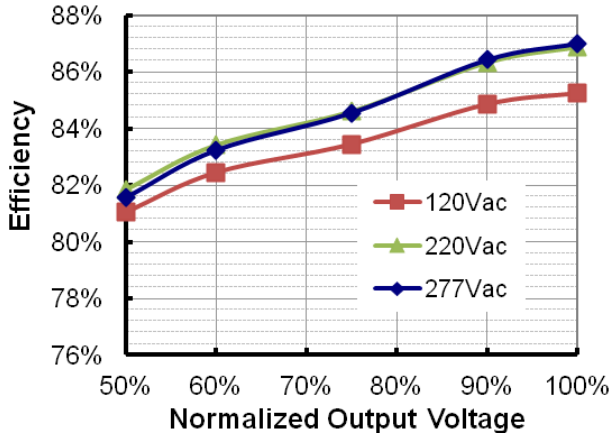

Power Factor Characteristics

PF vs. Output Voltage

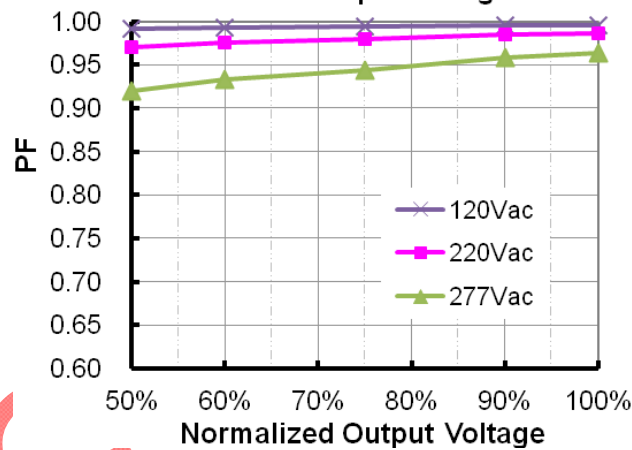

Total Harmonic Distortion

THD vs. Output Voltage

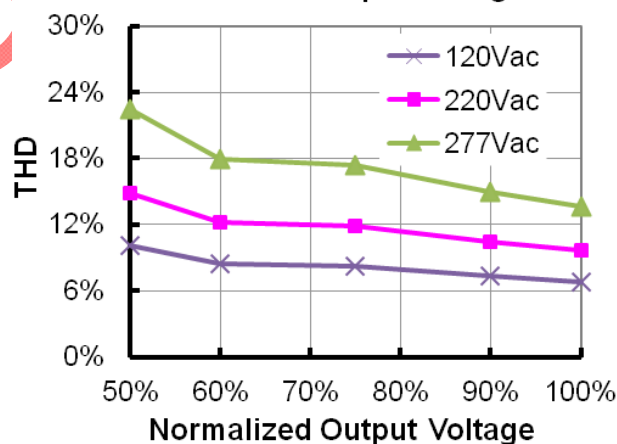

Dimming Control (On secondary side)

Parameter	Min.	Typ.	Max.	Notes
12V output voltage	10.8 V	12.0 V	13.2 V	
12V output source current	0 mA	-	20 mA	
Absolute Maximum Voltage on the 0~10V Wire	-20 V	-	20 V	
0~10V Wire Current Sourcing Capability	150 μ A	200 μ A	250 μ A	

The dimmer control is operated from an input signal of 0 – 10 Vdc. Recommended implementations are provided below.

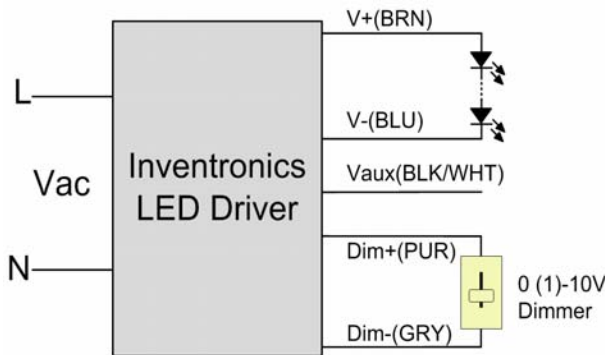

Output Current vs. Dimming Voltage

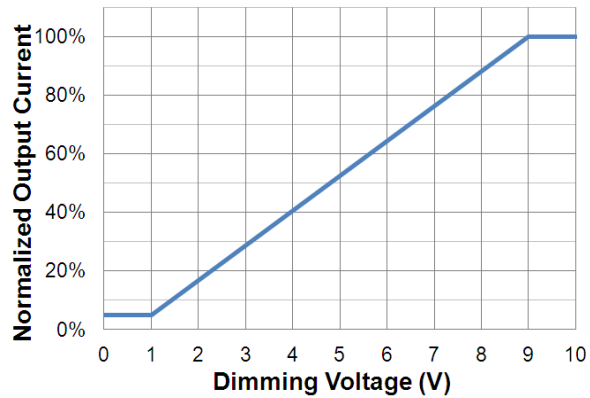

Implementation 1: DC Input

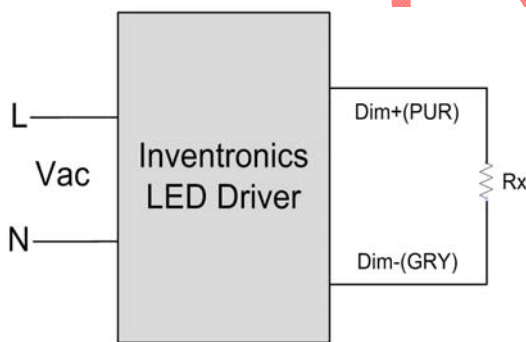

Io/Ir vs. Rx

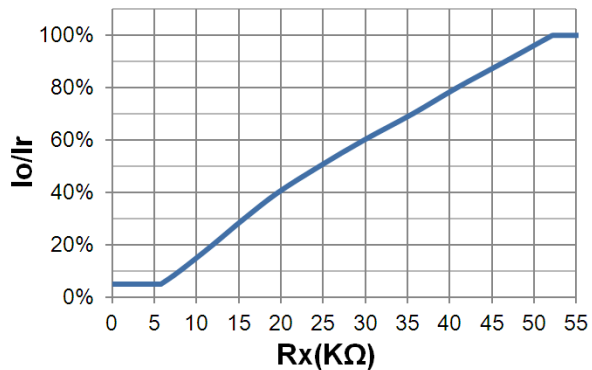

Implementation 2: External Resistor

Notes:

- The dimming signal is allowed to be less than 1V, however, when it is between 0-1V, the output current is 5%Io.
- Do not connect the dimming wires to the output; otherwise, the LED driver cannot work normally.
- If 0-10V dimming is not used, Dim + can be either open or connected to Vaux.

Mechanical Outline

LUC-066TxxxDDM

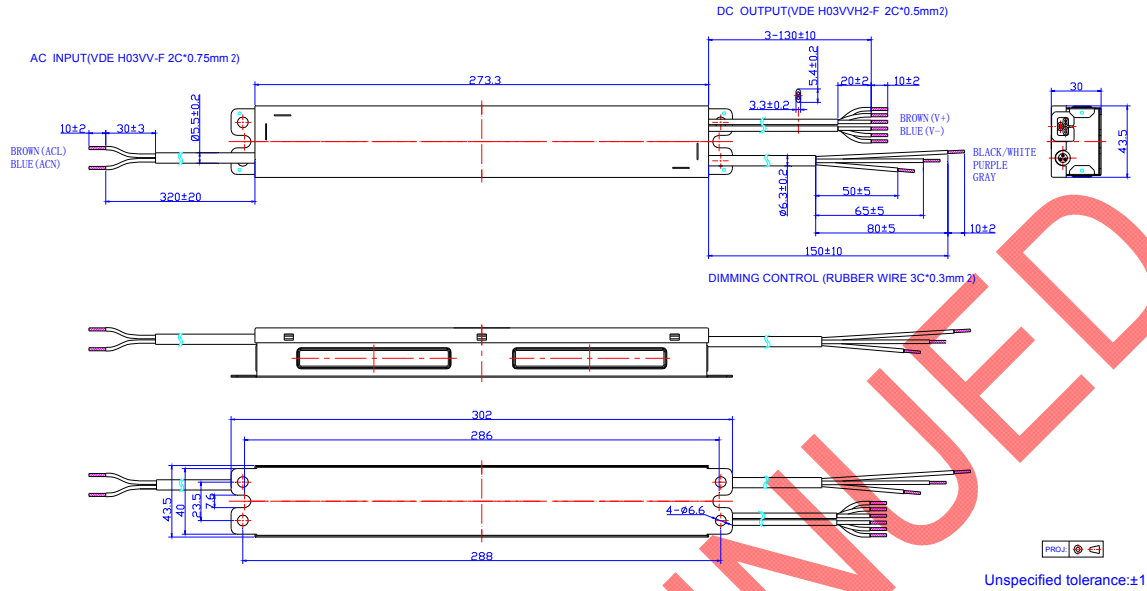

LUC-066TxxxSDM

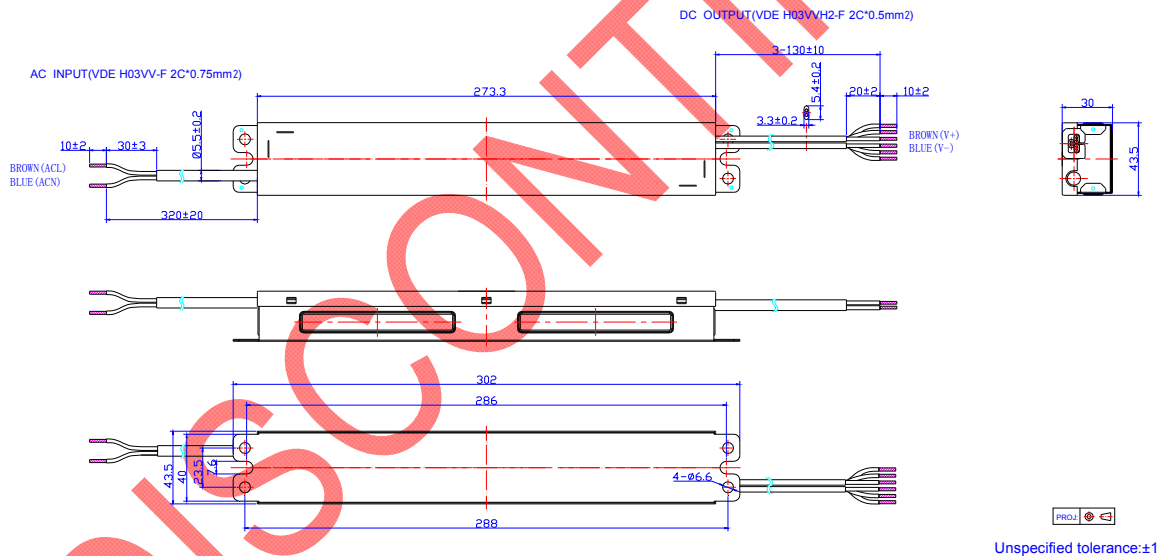

Notes:

1. For the driver to operate properly, the load voltage must be maintained above the minimum voltage threshold.
2. The three brown wires (Vout positive) are connected internally; the three blue wires (Vout negative) are separated inside.

RoHS Compliance

Our products comply with the European Directive 2011/65/EC, calling for the elimination of lead and other hazardous substances from electronic products.

Revision History

Change Date	Rev.	Description of Change						
		Item	From			To		
2013-07-02	A	Datasheets Release	/			/		
2013-08-14	B	Mechanical Outline---shape of output cable hole	/			Corrected		
		Io/Ir vs. Rx Curve	/			Added		
2014-1-10	C	OTP Description	/			Updated		
		0~10V Wire Current Sourcing Capability	Min	Typ	Max	Min	Typ	Max
			100uA	150uA	200uA	150uA	200uA	250uA

DISCONTINUED