

Features

- Inventronics patented metal case (Patent NO.: 201730183070.X)
- High Efficiency (Up to 92.0%)
- Full Power at Wide Output Current Range (Constant Power)
- 0-10V/10V PWM Dimmable
- Input surge protection: 4kV line-line, 6kV line-earth
- All-Around Protection: OVP, SCP, OTP
- Waterproof (IP67)
- SELV Output
- Suitable for Independent Use
- 5 Years Warranty



Description

The HUK-096SxxxDV series is a 96W, constant-current, programmable IP67 LED driver that operates from 90-305 Vac input with excellent power factor. It is designed in vertical type and specially created for bay lighting. The high efficiency of these drivers and compact metal case enables them to run cooler, significantly improving reliability and extending product life. To ensure trouble-free operation, protection is provided against input surge, output over voltage, short circuit, and over temperature.

Models

Adjustable Output Current Range	Full-Power Current Range (1)	Default Output Current	Input Voltage Range(2)	Output Voltage Range	Max. Output Power	Typical Efficiency (3)	Power Factor		Model Number
							120Vac	220Vac	
70-1050mA	700-1050mA	700 mA	90~305 Vac/ 127~250 Vdc	48~137Vdc	96 W	92.0%	0.99	0.96	HUK-096S105DV
140-2100mA	1400-2100mA	2100 mA	90~305 Vac/ 127~250 Vdc	24 ~ 69Vdc	96 W	91.0%	0.99	0.96	HUK-096S210DV ⁽⁴⁾
245-3500mA	2450-3500mA	2800 mA	90~305 Vac/ 127~250 Vdc	14 ~ 39Vdc	96 W	89.0%	0.99	0.96	HUK-096S350DV ⁽⁴⁾

- Notes:** (1) Output current range with constant power at 96W
 (2) Certified input voltage range: 100-240Vac or 127-250Vdc (except CCC, PSE, KS and BIS)
 (3) Measured at full load and 220Vac input (see below "General Specifications" for details).
 (4) SELV Output.

I-V Operation Area

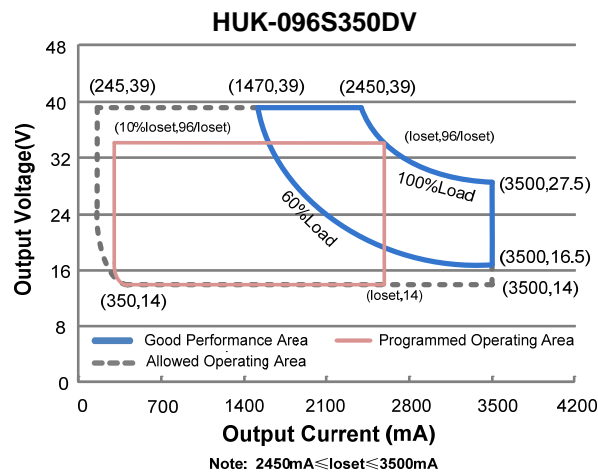
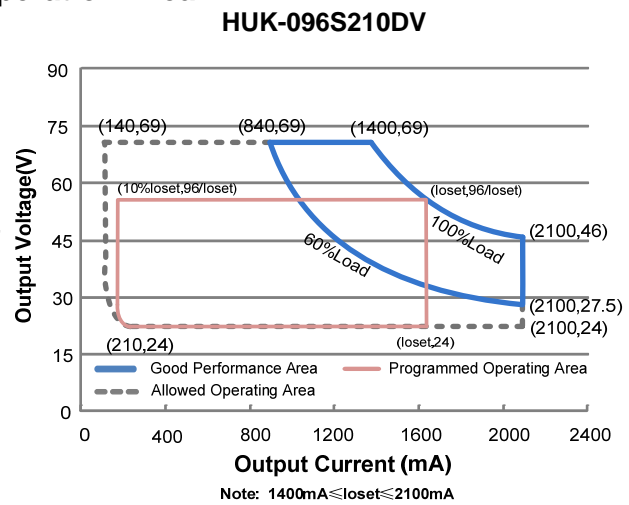
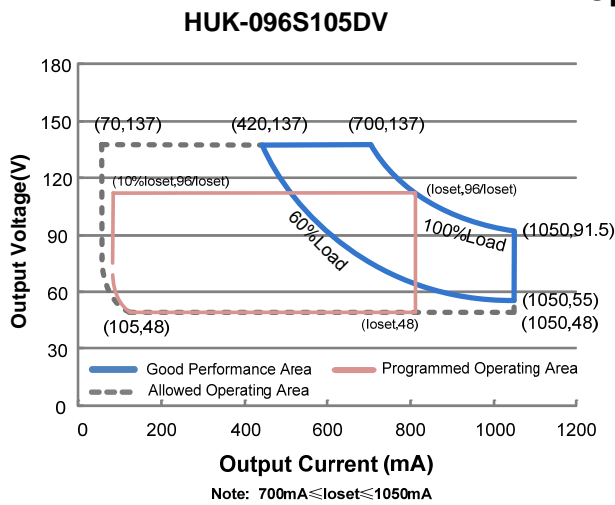

Input Specifications

Parameter	Min.	Typ.	Max.	Notes
Input Voltage	90 Vac	-	305 Vac	127~250 Vdc
Input Frequency	47 Hz	-	63 Hz	
Leakage Current	-	-	0.70 mA	IEC60598-1; 240Vac/ 60Hz
Input AC Current	-	-	0.95 A	Measured at full load and 120 Vac input.
	-	-	0.51 A	Measured at full load and 220 Vac input.
Inrush Current(I^2t)	-	-	1.20 A ² s	At 220Vac input, 25°C cold start, duration=344μs , 10%lpk-10%lpk. See Inrush Current Waveform for the details.

Input Specifications (Continued)

Parameter	Min.	Typ.	Max.	Notes
PF	0.9	-	-	At 100-240Vac, 50-60Hz, 60%-100% Load (58-96W)
THD	-	-	20%	
THD	-	-	10%	At 220-240Vac, 50-60Hz, 75%-100% Load (72-96W)

Output Specifications

Parameter	Min.	Typ.	Max.	Notes
Output Current Tolerance	-5%loset	-	5%loset	At full load condition
Output Current Setting(loset) Range				
HUK-096S105DV	70 mA	-	1050 mA	
HUK-096S210DV	140 mA	-	2100 mA	
HUK-096S350DV	245 mA	-	3500 mA	
Output Current Setting Range with Constant Power				
HUK-096S105DV	700 mA	-	1050 mA	
HUK-096S210DV	1400 mA	-	2100 mA	
HUK-096S350DV	2450 mA	-	3500 mA	
Total Output Current Ripple (pk-pk)	-	5%lomax	10%lomax	At full load condition. 20 MHz BW
Output Current Ripple at < 200 Hz (pk-pk)	-	2%lomax	-	At full load condition. Only this component of ripple is associated with visible flicker.
Startup Overshoot Current	-	-	10%lomax	At full load condition
No Load Output Voltage				
HUK-096S105DV	-	-	160 V	
HUK-096S210DV	-	-	89 V	
HUK-096S350DV	-	-	49V	
Line Regulation	-	-	±5%	Measured at full load
Load Regulation	-	-	±5%	
Turn-on Delay Time	-	-	1.0 s	Measured at 120Vac input, 60%-100% Load
	-	-	0.5 s	Measured at 220Vac input, 60%-100% Load
Temperature Coefficient of loset	-	0.06%/°C	-	Case temperature = 0°C ~Tc max

Note: All specifications are typical at 25°C unless otherwise stated.

General Specifications

Parameter	Min.	Typ.	Max.	Notes
Efficiency at 120 Vac input: HUK-096S105DV I _o = 700 mA I _o =1050 mA HUK-096S210DV I _o =1400 mA I _o =2100 mA HUK-096S350DV I _o =2450 mA I _o =3500 mA	87.5% 87.5% 86.5% 87.0% 84.5% 84.5%	89.5% 89.5% 88.5% 89.0% 86.5% 86.5%	- - - - - -	Measured at full load and steady-state temperature in 25°C ambient; (Efficiency will be about 2.0% lower if measured immediately after startup.)
Efficiency at 220 Vac input: HUK-096S105DV I _o = 700 mA I _o =1050 mA HUK-096S210DV I _o =1400 mA I _o =2100 mA HUK-096S350DV I _o =2450 mA I _o =3500 mA	89.5% 90.0% 88.5% 89.0% 87.0% 86.5%	91.5% 92.0% 90.5% 91.0% 89.0% 88.5%	- - - - - -	Measured at full load and steady-state temperature in 25°C ambient; (Efficiency will be about 2.0% lower if measured immediately after startup.)
Efficiency at 277 Vac input: HUK-096S105DV I _o = 700 mA I _o =1050 mA HUK-096S210DV I _o =1400 mA I _o =2100 mA HUK-096S350DV I _o =2450 mA I _o =3500 mA	89.5% 90.0% 89.0% 89.0% 87.5% 87.0%	91.5% 92.0% 91.0% 91.0% 89.5% 89.0%	- - - - - -	Measured at full load and steady-state temperature in 25°C ambient; (Efficiency will be about 2.0% lower if measured immediately after startup.)
MTBF	-	422,000 Hours	-	Measured at 220Vac input, 80%Load and 25°C ambient temperature (MIL-HDBK-217F)
Lifetime	-	108,000 Hours	-	Measured at 220Vac input, 80%Load and 70°C case temperature; See lifetime vs. T _c curve for the details
Operating Case Temperature for Safety T _{c_s}	-40°C	-	+90°C	
Operating Case Temperature for Warranty T _{c_w}	-40°C	-	+75°C	Case temperature for 5 years warranty
Storage Temperature	-40°C	-	+85°C	Humidity: 5%RH to 100%RH
Dimensions Inches (L × W × H) Millimeters (L × W × H)	6.50 × 2.68 × 2.68 165 × 68 × 68			
Net Weight	-	1140 g	-	

Note: All specifications are typical at 25°C unless otherwise stated.

Dimming Specifications

Parameter		Min.	Typ.	Max.	Notes
Absolute Maximum Voltage on the Vdim (+) Pin		-20 V	-	20 V	
Source Current on Vdim (+)Pin		200 uA	300 uA	450 uA	Vdim(+) = 0 V
Dimming Output Range	HUK-096S105DV HUK-096S210DV HUK-096S350DV	10%loset	-	loset	700mA ≤ loset ≤ 1050mA 1400mA ≤ loset ≤ 2100mA 2450mA ≤ loset ≤ 3500mA
	HUK-096S105DV HUK-096S210DV HUK-096S350DV	70 mA 140 mA 245 mA	-	loset	70mA ≤ loset < 700mA 140mA ≤ loset < 1400mA 245mA ≤ loset < 2450mA
Recommended Dimming Range for 0-10V		0 V	-	10 V	Default 0-10V dimming mode.
PWM_in High Level		-	10V	-	
PWM_in Low Level		-	0V	-	
PWM_in Frequency Range		200 Hz	-	2 KHz	
PWM_in Duty Cycle		0%	-	100%	

Safety & EMC Compliance

Safety Category	Standard
CE	EN 61347-1, EN61347-2-13
CCC	GB 19510.1, GB 19510.14
KS	KS C 7655
EMI Standards	Notes
EN 55015/GB 17743 ⁽¹⁾	Conducted emission Test & Radiated emission Test
EN 61000-3-2/GB 17625.1	Harmonic current emissions
EN 61000-3-3	Voltage fluctuations & flicker
EMS Standards	Notes
EN 61000-4-2	Electrostatic Discharge (ESD): 8 kV air discharge, 4 kV contact discharge
EN 61000-4-3	Radio-Frequency Electromagnetic Field Susceptibility Test-RS
EN 61000-4-4	Electrical Fast Transient / Burst-EFT: level 3, criteria A
EN 61000-4-5	Surge Immunity Test: AC Power Line: line to line 4 kV, line to earth 6 kV
EN 61000-4-6	Conducted Radio Frequency Disturbances Test-CS
EN 61000-4-8	Power Frequency Magnetic Field Test
EN 61000-4-11	Voltage Dips
EN 61547	Electromagnetic Immunity Requirements Applies To Lighting Equipment

Note: (1) This LED driver meets the EMI specifications above, but EMI performance of a luminaire that contains it depends also on the other devices connected to the driver and on the fixture itself.

Derating

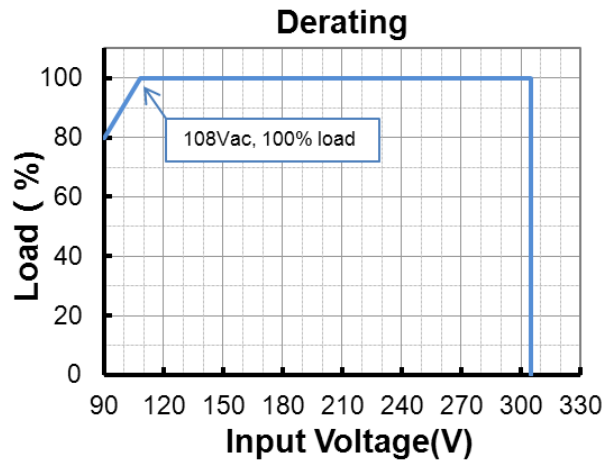

Lifetime vs. Case Temperature

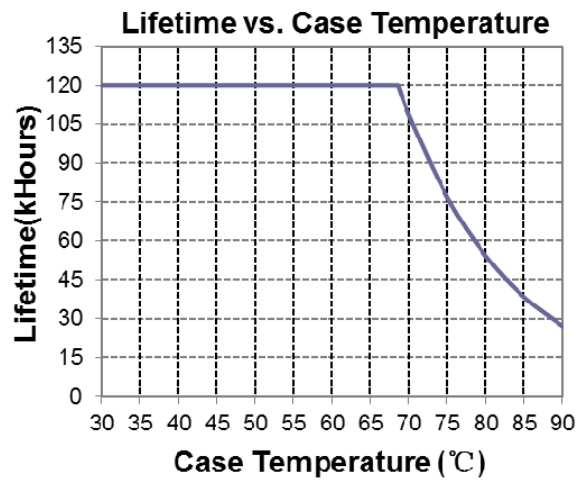

Inrush Current Waveform

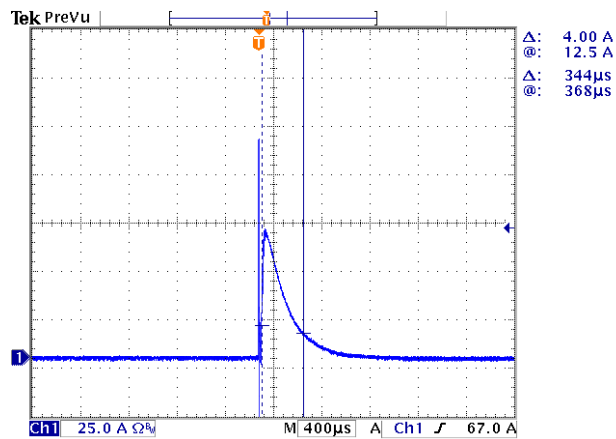

Efficiency vs. Load

HUK-096S105DV($I_o=700mA$)

Efficiency vs. Output Voltage

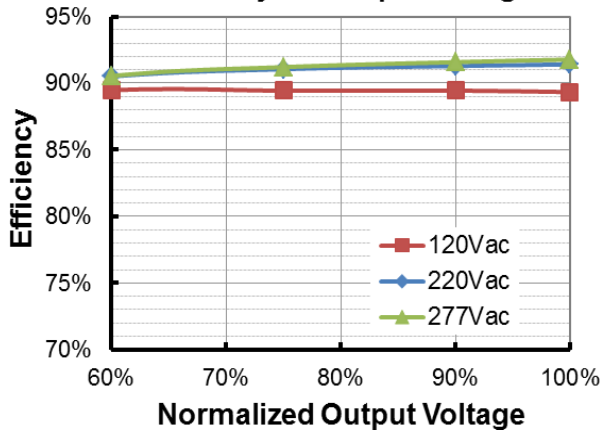

HUK-096S105DV($I_o=1050mA$)

Efficiency vs. Output Voltage

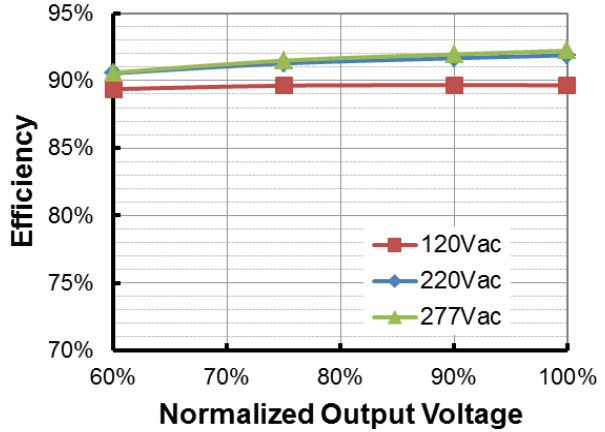

HUK-096S210DV($I_o=1400mA$)

Efficiency vs. Output Voltage

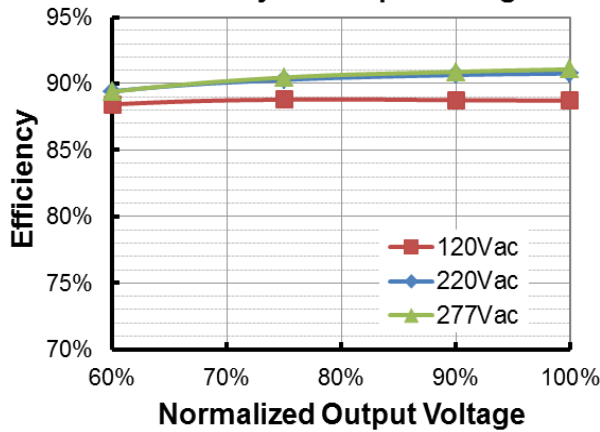

HUK-096S210DV($I_o=2100mA$)

Efficiency vs. Output Voltage

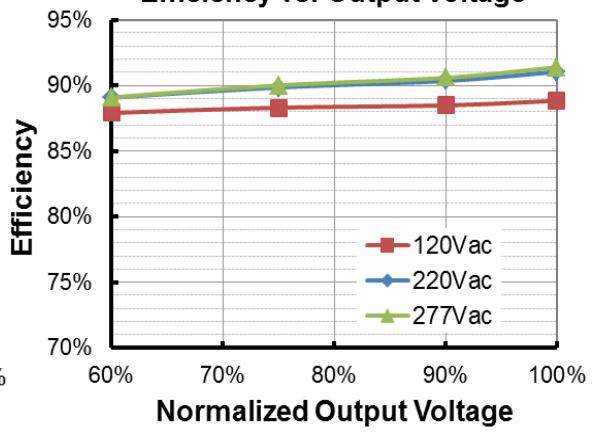

HUK-096S350DV($I_o=2450mA$)

Efficiency vs. Output Voltage

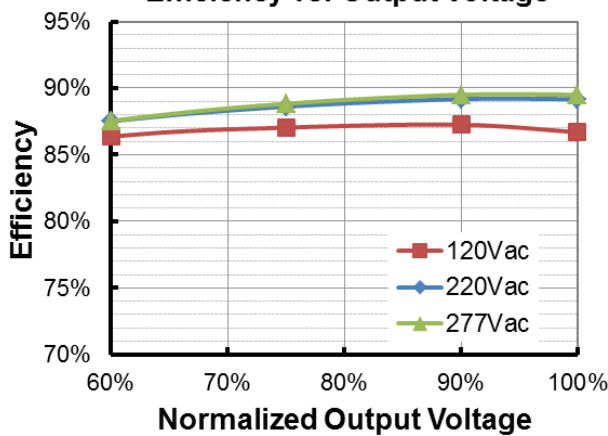

HUK-096S350DV($I_o=3500mA$)

Efficiency vs. Output Voltage

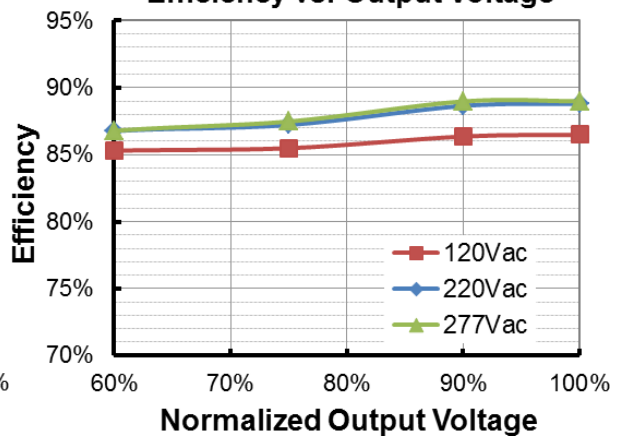

Power Factor

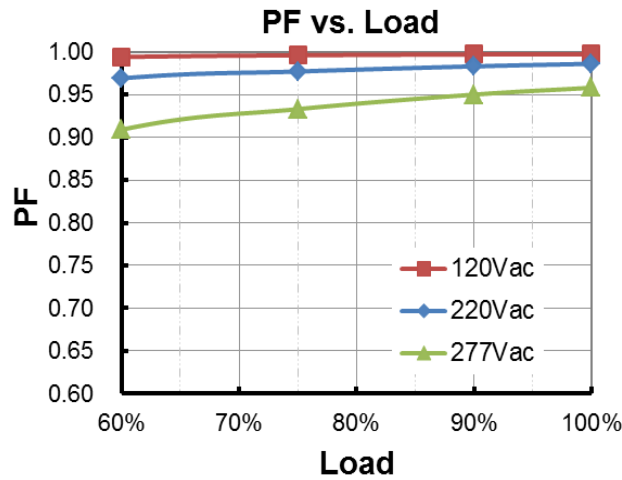

Total Harmonic Distortion

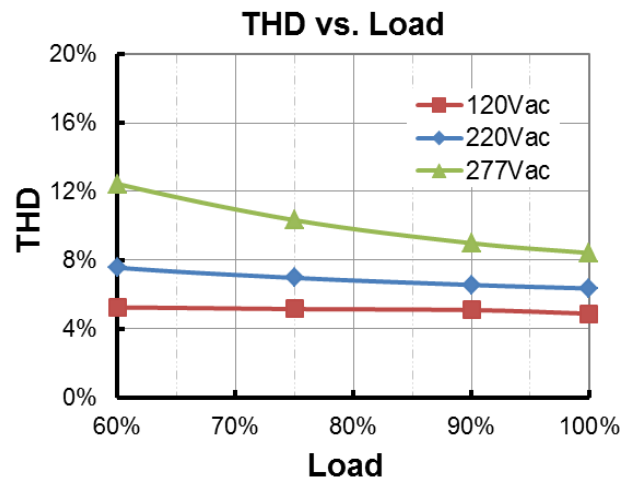

Protection Functions

Parameter	Notes
Over Temperature Protection	Decreases output current, returning to normal after over temperature is removed.
Short Circuit Protection	Auto Recovery. No damage will occur when any output is short circuited. The output shall return to normal when the fault condition is removed.
Over Voltage Protection	Limits output voltage at no load and in case the normal voltage limit fails.

Dimming

● 0-10V Dimming

The recommended implementation of the dimming control is provided below.

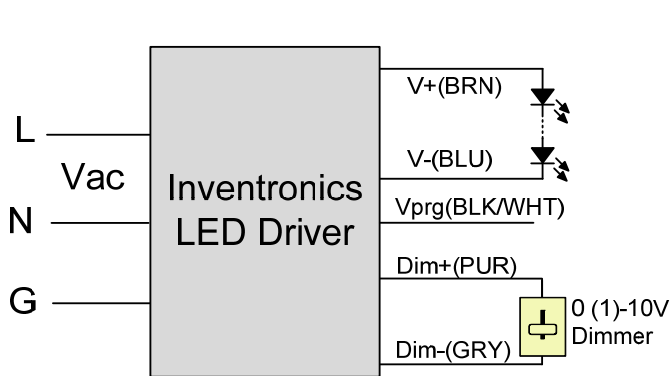

Implementation 1

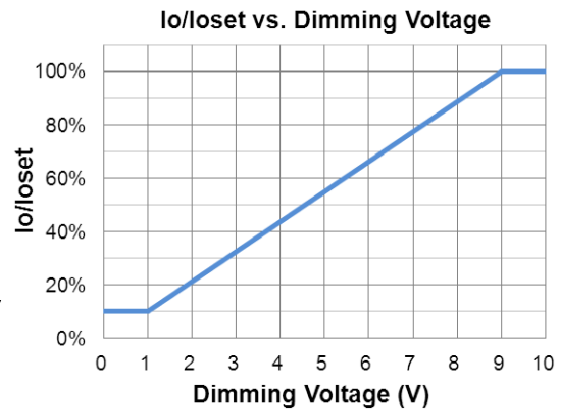

Notes:

1. The dimmer can also be replaced by an active 0-10V voltage source signal or passive components like resistors and zener.
2. If 0-10V dimming is not used, Dim + should be open.

● 10V PWM Dimming

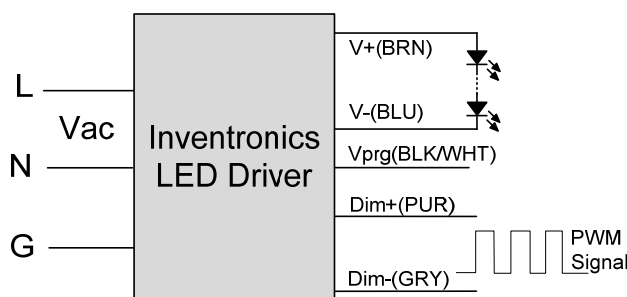

Implementation 2

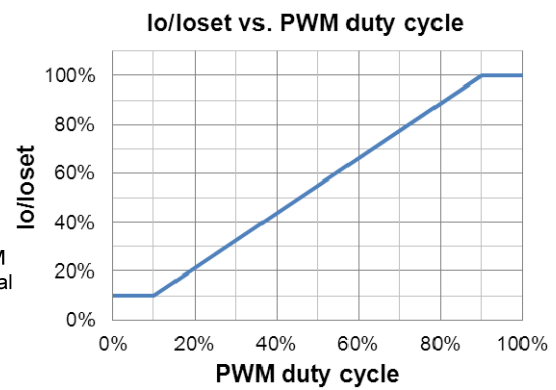

Notes:

1. If PWM dimming is not used, Dim + should be open.

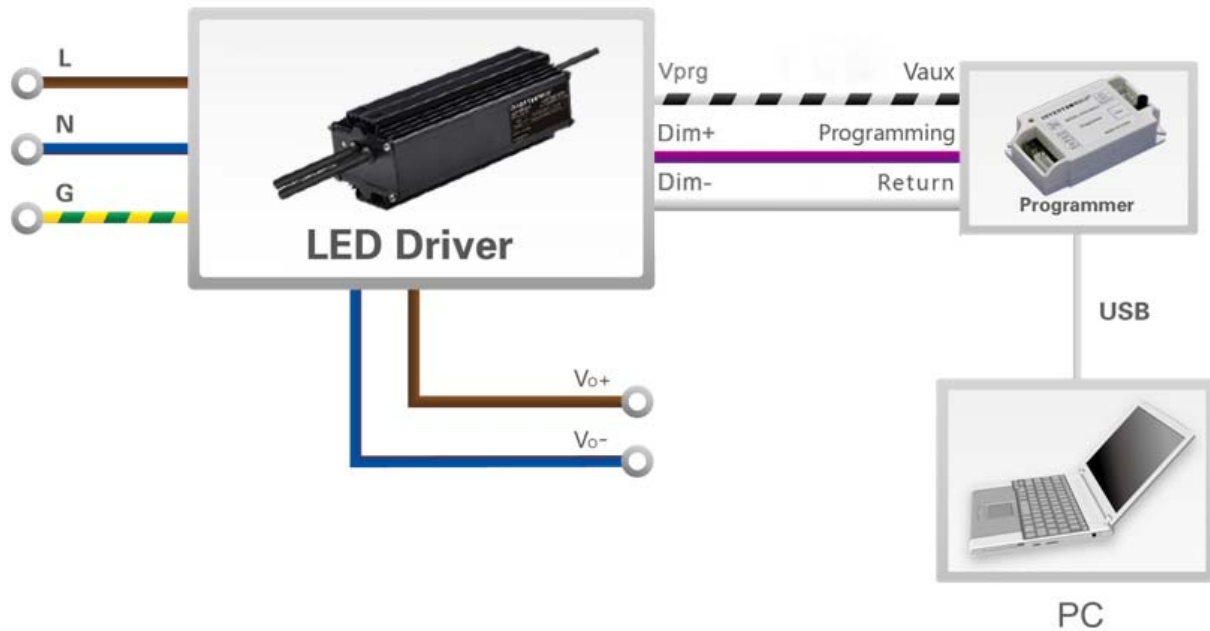

Programming Connection Diagram



Note: The driver does not need to be powered on during the programming process.

- Please refer to [PRG-MUL2](#) Multi-Programmer datasheet for details.

Installations

Assembly Method		Option 1	Option 2	Option 3	Option 4
Product Type		Center Wire Feed		Outside Wire Feed	
Part Numbers for Accessories	Upper Bracket	BRK-UPR00	BRK-UPR00	BRK-UPR01	BRK-UPR01
	Bottom Bracket	BRK-BTM00	BRK-BTM01	BRK-BTM00	BRK-BTM01
	Hook / Eye Bolt	HKK-D1500	HKK-D1500	BLT-M1200	BLT-M1200
Product Appearance					

Installations (Continued)



Caution:

1. Complete visual inspection prior to assembly to insure driver is received in proper condition.
2. Mounting accessory (hook, ring, etc.) has to be tightened completely. After mounting accessory (hook, ring, etc.) is installed an M3 set screw should be secured in the open location on the driver collar.
3. Maximum weight of combined luminaire/driver assembly should not exceed 20Kg.

Mechanical Outline

HUK-096SxxxDV

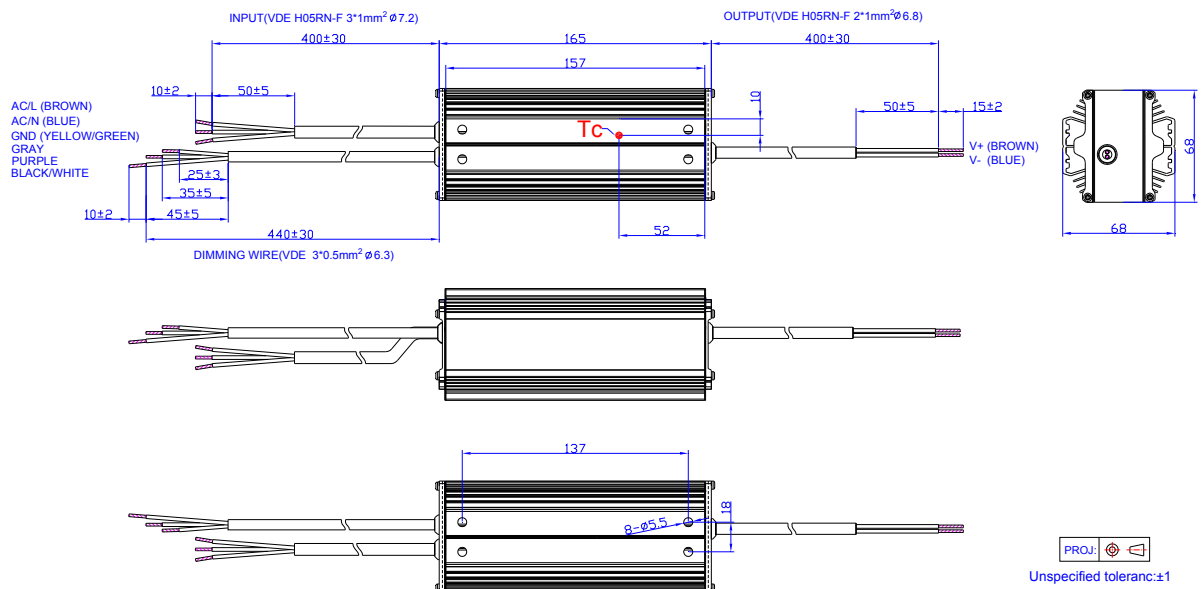

Optional Brackets BRK-UPR00

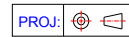
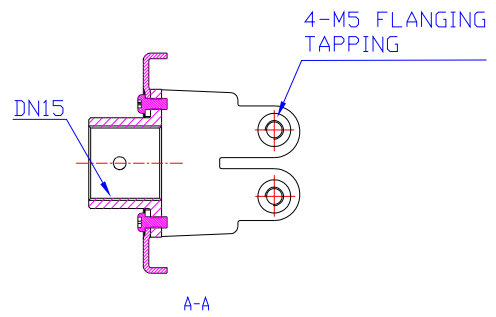
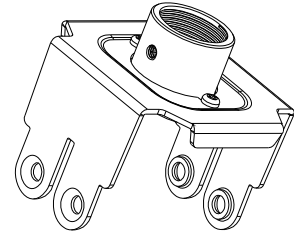
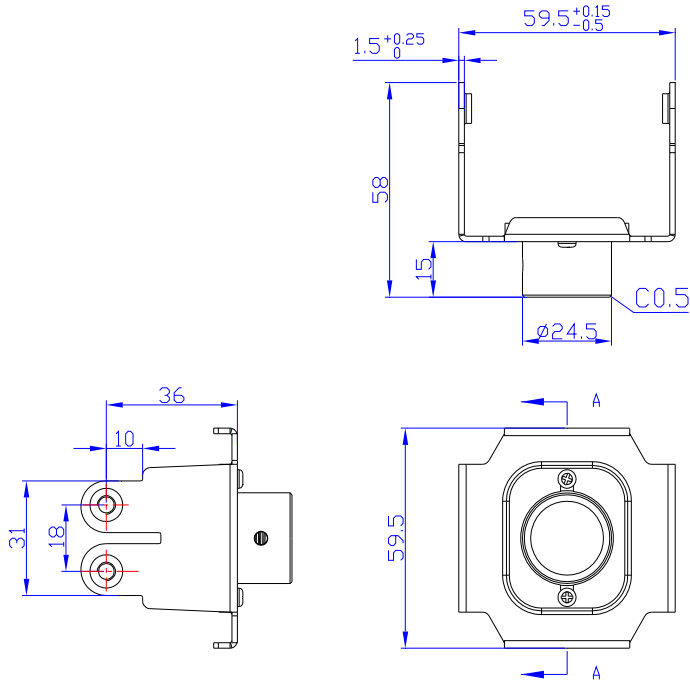

Unspecified tolerance: ±1

BRK-UPR01

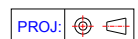
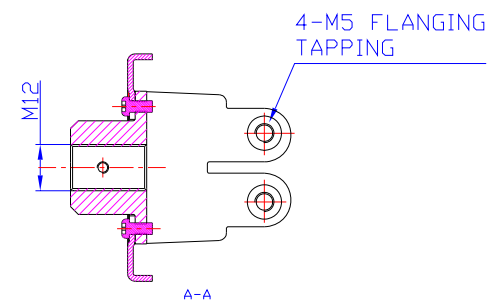
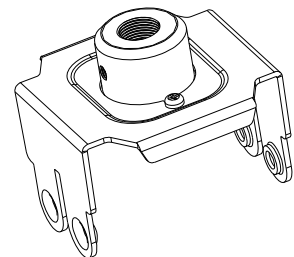
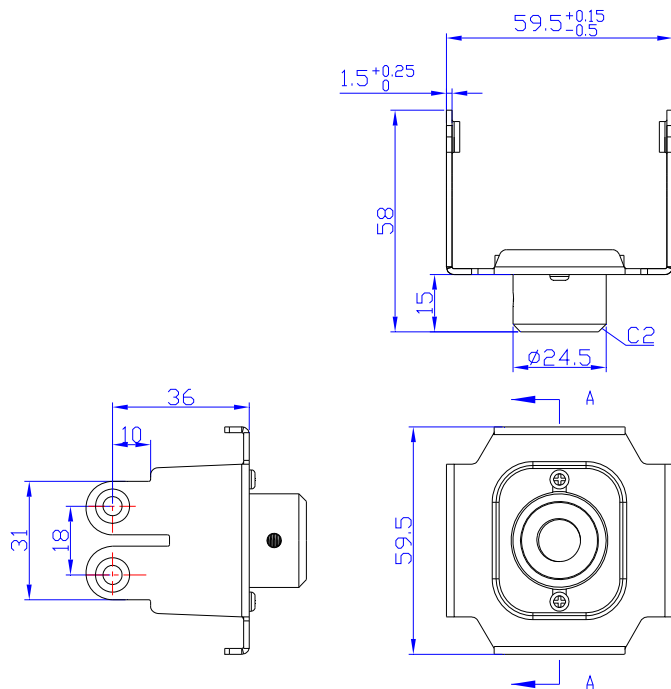

Unspecified tolerance: ±1

BRK-BTM00

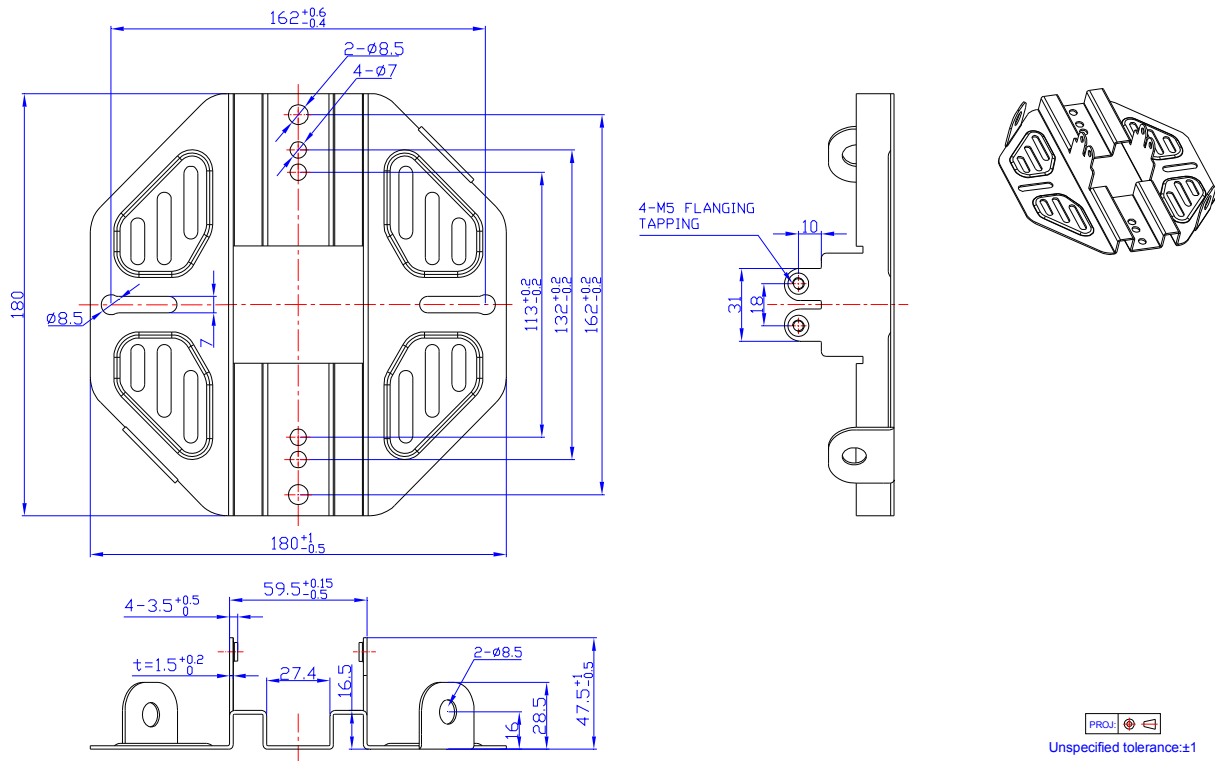

BRK-BTM01

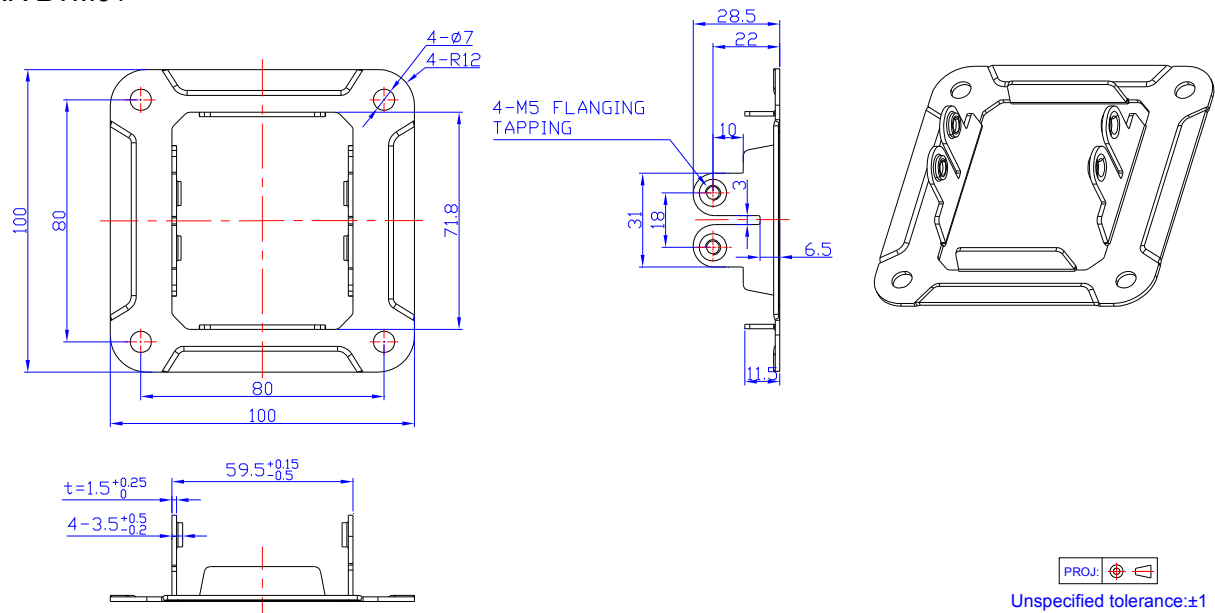

Optional Metal Parts

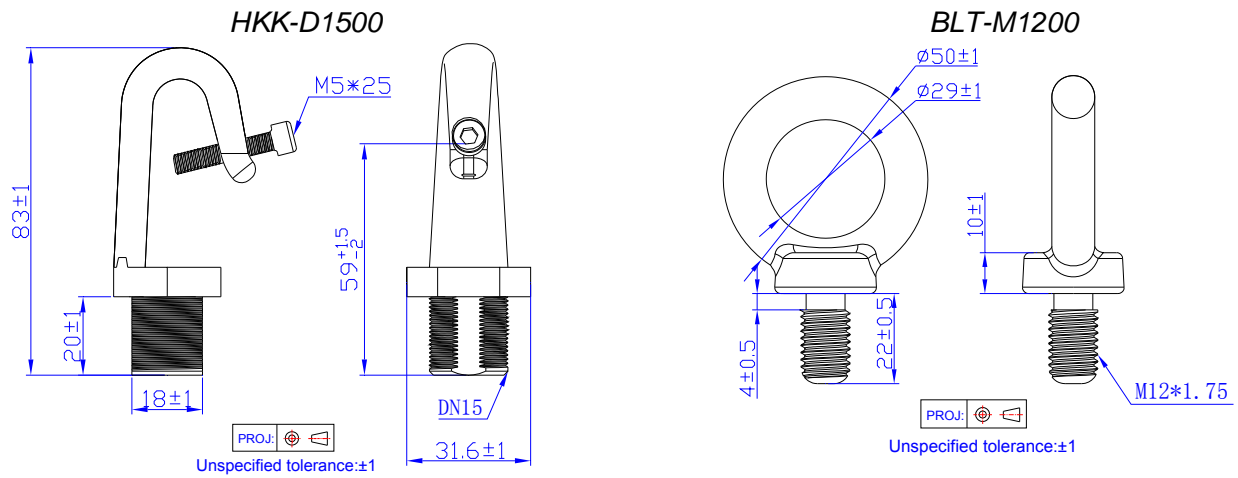

Note: The brackets are to be installed with HUK-096SxxxDV drivers for field application. Please refer to [BRK-UPR\(BTM\)xx](#) datasheet for details.

RoHS Compliance

Our products comply with the European Directive 2011/65/EC, calling for the elimination of lead and other hazardous substances from electronic products.

Revision History

Change Date	Rev.	Description of Change		
		Item	From	To
2018-02-07	A	Datasheets Created	/	/