

## Features

- Full Power at Wide Output Current Range (Constant Power)
- Adjustable Output Current (AOC) with Programmability
- Isolated 1-5V/1-10V/10V PWM/3-Timer-Modes Dimmable
- Output Lumen Compensation
- Input Surge Protection: DM 6kV, CM 10kV
- All-Around Protection: OVP, SCP, OTP
- IP66/IP67
- SELV Output
- Suitable for Luminaires with Protection Class I and II
- 5 Years Warranty



## Description

The EUM-075SxxxDE series is a 75W, constant-current, programmable and IP66/IP67 rated LED driver that operates from 90-305Vac input with excellent power factor. It is created for many lighting applications including low bay, tunnel and roadway etc. The high efficiency of these drivers and compact metal case enables them to run cooler, significantly improving reliability and extending product life. To ensure trouble-free operation, protection is provided against input surge, output over voltage, short circuit, and over temperature.

## Models

Adjustable Output Current Range	Full-Power Current Range(1)	Default Output Current	Input Voltage Range(2)	Output Voltage Range	Max. Output Power	Typical Efficiency (3)	Typical Power Factor		Model Number
							120Vac	220Vac	
30-530mA	300-530mA	530 mA	90~305 Vac/ 127~300 Vdc	70~250 Vdc	75W	92.0%	0.99	0.96	EUM-075S053DE
70-1050mA	700-1050mA	700 mA	90~305 Vac/ 127~300 Vdc	36~107 Vdc	75W	90.5%	0.99	0.96	EUM-075S105DE <sup>(4)</sup>
105-1500mA	1050-1500mA	1050 mA	90~305 Vac/ 127~300 Vdc	25~72 Vdc	75W	90.5%	0.99	0.96	EUM-075S150DE <sup>(4)</sup>
140-2100mA	1400-2100mA	2100 mA	90~305 Vac/ 127~300 Vdc	18~54 Vdc	75W	89.5%	0.99	0.96	EUM-075S210DE <sup>(4)</sup>

- Notes:** (1) Output current range with constant power at 75W  
 (2) Certified input voltage range: 100-240Vac.  
 (3) Measured at 100% load and 220Vac input (see below "General Specifications" for details).  
 (4) SELV output.

## I-V Operation Area

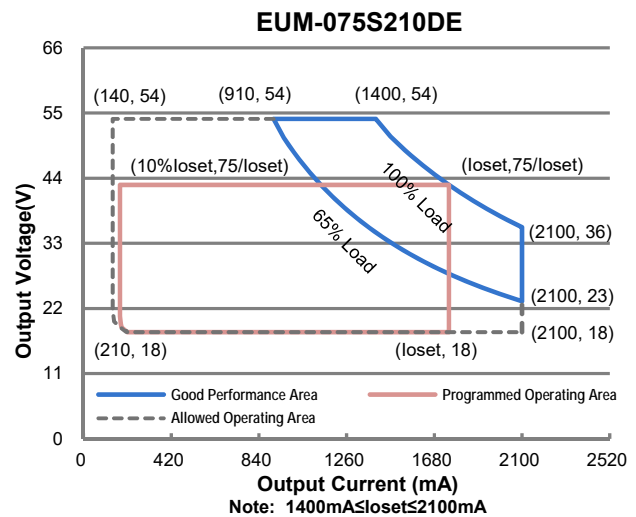
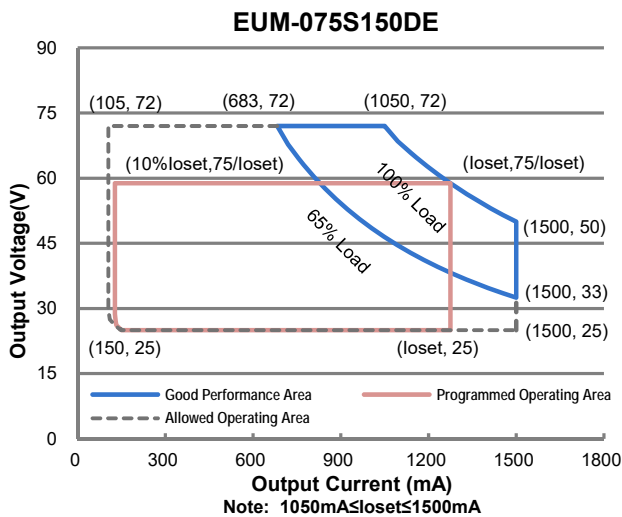
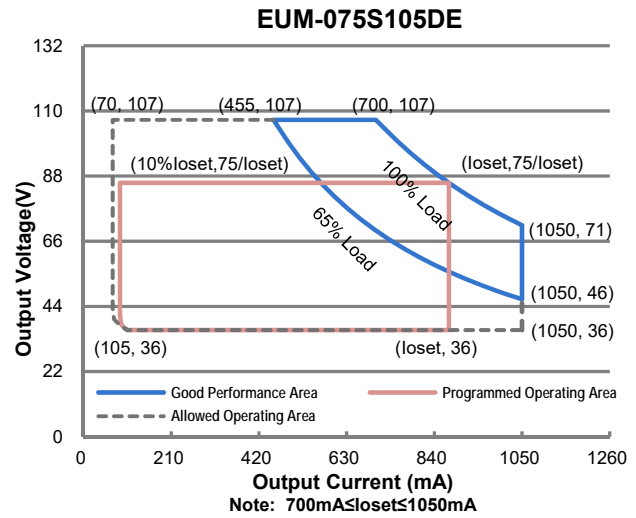
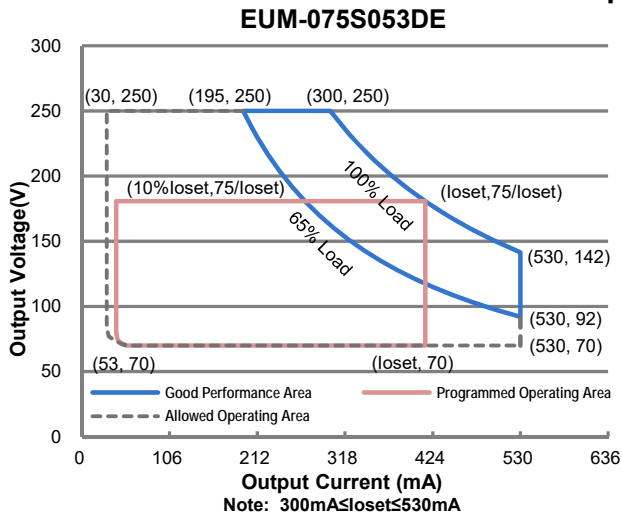

## Input Specifications

Parameter	Min.	Typ.	Max.	Notes
Input AC Voltage	90 Vac	-	305 Vac	
Input DC Voltage	127 Vdc	-	300 Vdc	
Input Frequency	47 Hz	-	63 Hz	
Leakage Current	-	-	0.70 mA	IEC 60598-1; 240Vac/ 60Hz
Input AC Current	-	-	0.79 A	Measured at 100% load and 120 Vac input.
	-	-	0.43 A	Measured at 100% load and 220 Vac input.
Inrush Current(I <sup>2</sup> t)	-	-	0.90 A <sup>2</sup> s	At 220Vac input, 25°C cold start, duration=284 μs, 10%I <sub>pk</sub> -10%I <sub>pk</sub> . See Inrush Current Waveform for the details.

## Input Specifications (Continued)

Parameter	Min.	Typ.	Max.	Notes
PF	0.9	-	-	At 100-277Vac, 50-60Hz, 65%-100% Load (49-75W)
THD	-	-	20%	
THD	-	-	10%	At 220-240Vac, 50-60Hz, 75%-100% Load (56-75W)

## Output Specifications

Parameter	Min.	Typ.	Max.	Notes
Output Current Tolerance	-5%loset	-	5%loset	At 100% load condition
Output Current Setting(loset) Range				
EUM-075S053DE	30 mA	-	530 mA	
EUM-075S105DE	70 mA	-	1050 mA	
EUM-075S150DE	105 mA	-	1500 mA	
EUM-075S210DE	140 mA	-	2100 mA	
Output Current Setting Range with Constant Power				
EUM-075S053DE	300 mA	-	530 mA	
EUM-075S105DE	700 mA	-	1050 mA	
EUM-075S150DE	1050 mA	-	1500 mA	
EUM-075S210DE	1400 mA	-	2100 mA	
Total Output Current Ripple (pk-pk)	-	5%lomax	10%lomax	At 100% load condition. 20 MHz BW
Output Current Ripple at < 200 Hz (pk-pk)	-	2%lomax	-	At 100% load condition. Only this component of ripple is associated with visible flicker.
Startup Overshoot Current	-	-	10%lomax	At 100% load condition
No Load Output Voltage				
EUM-075S053DE	-	-	330 V	
EUM-075S105DE	-	-	120 V	
EUM-075S150DE	-	-	90 V	
EUM-075S210DE	-	-	60 V	
Line Regulation	-	-	±1%	Measured at 100% load
Load Regulation	-	-	±5%	
Turn-on Delay Time	-	-	0.5 s	Measured at 120-277Vac input, 65%-100% Load
Temperature Coefficient of loset	-	0.06%/°C	-	Case temperature = 0°C ~Tc max

## General Specifications

Parameter	Min.	Typ.	Max.	Notes
Efficiency at 120 Vac input: EUM-075S053DE				Measured at 100% load and steady-state temperature in 25°C ambient; (Efficiency will be about 2.0% lower if measured immediately after startup.)
I <sub>o</sub> = 300 mA	86.5%	88.5%	-	
I <sub>o</sub> = 530 mA	87.5%	89.5%	-	
EUM-075S105DE				
I <sub>o</sub> = 700 mA	86.0%	88.0%	-	
I <sub>o</sub> =1050 mA	86.5%	88.5%	-	
EUM-075S150DE				
I <sub>o</sub> =1050 mA	85.5%	87.5%	-	
I <sub>o</sub> =1500 mA	86.0%	88.0%	-	
EUM-075S210DE				
I <sub>o</sub> =1400 mA	85.0%	87.0%	-	
I <sub>o</sub> =2100 mA	85.0%	87.0%	-	
Efficiency at 220 Vac input: EUM-075S053DE				Measured at 100% load and steady-state temperature in 25°C ambient; (Efficiency will be about 2.0% lower if measured immediately after startup.)
I <sub>o</sub> = 300 mA	89.0%	91.0%	-	
I <sub>o</sub> = 530 mA	90.0%	92.0%	-	
EUM-075S105DE				
I <sub>o</sub> = 700 mA	88.5%	90.5%	-	
I <sub>o</sub> =1050 mA	88.5%	90.5%	-	
EUM-075S150DE				
I <sub>o</sub> =1050 mA	88.0%	90.0%	-	
I <sub>o</sub> =1500 mA	88.5%	90.5%	-	
EUM-075S210DE				
I <sub>o</sub> =1400 mA	87.5%	89.5%	-	
I <sub>o</sub> =2100 mA	87.5%	89.5%	-	
Efficiency at 277 Vac input: EUM-075S053DE				Measured at 100% load and steady-state temperature in 25°C ambient; (Efficiency will be about 2.0% lower if measured immediately after startup.)
I <sub>o</sub> = 300 mA	89.0%	91.0%	-	
I <sub>o</sub> = 530 mA	90.0%	92.0%	-	
EUM-075S105DE				
I <sub>o</sub> = 700 mA	88.5%	90.5%	-	
I <sub>o</sub> =1050 mA	89.0%	91.0%	-	
EUM-075S150DE				
I <sub>o</sub> =1050 mA	88.5%	90.5%	-	
I <sub>o</sub> =1500 mA	88.5%	90.5%	-	
EUM-075S210DE				
I <sub>o</sub> =1400 mA	87.5%	89.5%	-	
I <sub>o</sub> =2100 mA	88.0%	90.0%	-	
MTBF	-	521,000 Hours	-	Measured at 220Vac input, 80%Load and 25°C ambient temperature (MIL-HDBK-217F)
Lifetime	-	100,000 Hours	-	Measured at 220Vac input, 80%Load and 70°C case temperature; See lifetime vs. Tc curve for the details
Operating Case Temperature for Safety T <sub>c_s</sub>	-40°C	-	+90°C	
Operating Case Temperature for Warranty T <sub>c_w</sub>	-40°C	-	+80°C	Case temperature for 5 years warranty Humidity: 10% RH to 95% RH
Storage Temperature	-40°C	-	+85°C	Humidity: 5% RH to 95% RH
Dimensions Inches (L × W × H) Millimeters (L × W × H)	5.35 × 2.36 × 1.44 136 × 60 × 36.5			With mounting ear 6.02 × 2.36 × 1.44 153 × 60 × 36.5
Net Weight	-	614g	-	

## Dimming Specifications

Parameter		Min.	Typ.	Max.	Notes
Absolute Maximum Voltage on the Vdim (+) Pin		-20 V	-	20 V	
Source Current on Vdim (+)Pin		200 uA	300 uA	450 uA	Vdim(+) = 0 V
Dimming Output Range	EUM-075S053DE EUM-075S105DE EUM-075S150DE EUM-075S210DE	10%loset	-	loset	300 mA ≤ loset ≤ 530 mA 700 mA ≤ loset ≤ 1050 mA 1050 mA ≤ loset ≤ 1500 mA 1400 mA ≤ loset ≤ 2100 mA
	EUM-075S053DE EUM-075S105DE EUM-075S150DE EUM-075S210DE	30 mA 70 mA 105 mA 140 mA	-	loset	30 mA ≤ loset < 300 mA 70 mA ≤ loset < 700 mA 105 mA ≤ loset < 1050 mA 140 mA ≤ loset < 1400 mA
Recommended Dimming Range for 1-5V		0.25 V	-	4.75 V	Dimming mode set to 1-5V in PC interface.
Recommended Dimming Range for 1-10V		1 V	-	9 V	Default 1-10V dimming mode with positive logic.
PWM_in High Level		-	10V	-	
PWM_in Low Level		-	0V	-	
PWM_in Frequency Range		200 Hz	-	2 KHz	
PWM_in Duty Cycle		0%	-	100%	

## Safety & EMC Compliance

Safety Category	Standard
ENEC & CE	EN 61347-1 <sup>(1)</sup> , EN 61347-2-13
UKCA	BS EN 61347-1 <sup>(1)</sup> , BS EN 61347-2-13
CB	IEC 61347-1 <sup>(1)</sup> , IEC 61347-2-13
KS	KS C 7655
Performance	Standard
ENEC	EN 62384
EMI Standards	Notes
BS EN/EN IEC 55015 <sup>(2)</sup>	Conducted emission Test & Radiated emission Test
BS EN/EN IEC 61000-3-2	Harmonic current emissions
BS EN/EN 61000-3-3	Voltage fluctuations & flicker
EMS Standards	Notes
BS EN/EN 61000-4-2	Electrostatic Discharge (ESD): 8kV air discharge, 4kV contact discharge
BS EN/EN 61000-4-3	Radio-Frequency Electromagnetic Field Susceptibility Test-RS
BS EN/EN 61000-4-4	Electrical Fast Transient / Burst-EFT

## Safety & EMC Compliance (Continued)

EMS Standards	Notes
BS EN/EN 61000-4-5	Surge Immunity Test: AC Power Line: Differential Mode 6kV, Common Mode 10kV
BS EN/EN 61000-4-6	Conducted Radio Frequency Disturbances Test-CS
BS EN/EN 61000-4-8	Power Frequency Magnetic Field Test
BS EN/EN 61000-4-11	Voltage Dips
BS EN/EN 61547	Electromagnetic Immunity Requirements Applies To Lighting Equipment

**Note:** (1) This product meets the requirements for IEC/BS EN/EN 61347-1(Class II), when the driver is energized, the allowed leakage current is perceptible but harmless.

(2) This LED driver meets the EMI specifications above, but EMI performance of a luminaire that contains it depends also on the other devices connected to the driver and on the fixture itself.

## Derating

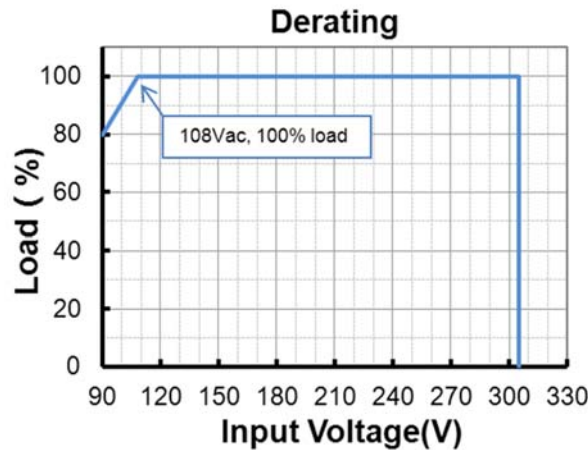

## Lifetime vs. Case Temperature

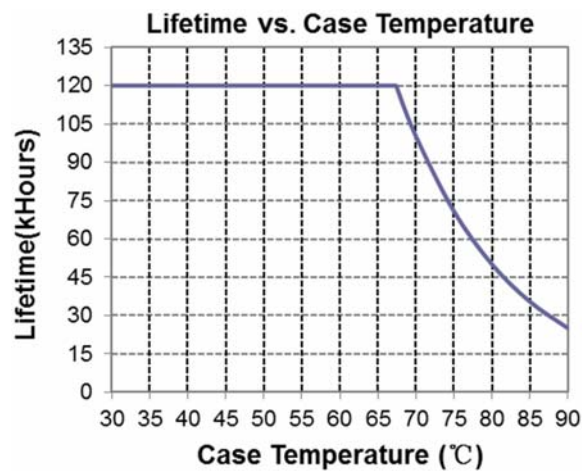



## Inrush Current Waveform

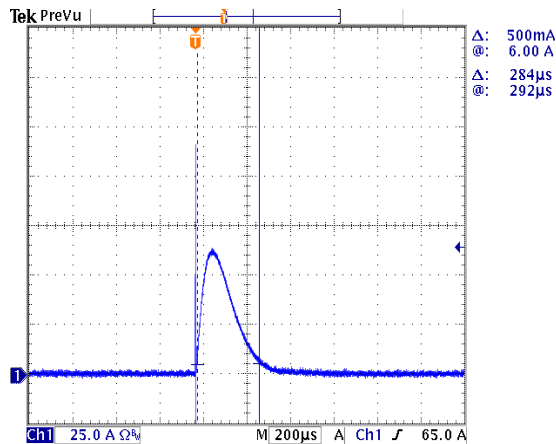

## Efficiency vs. Load

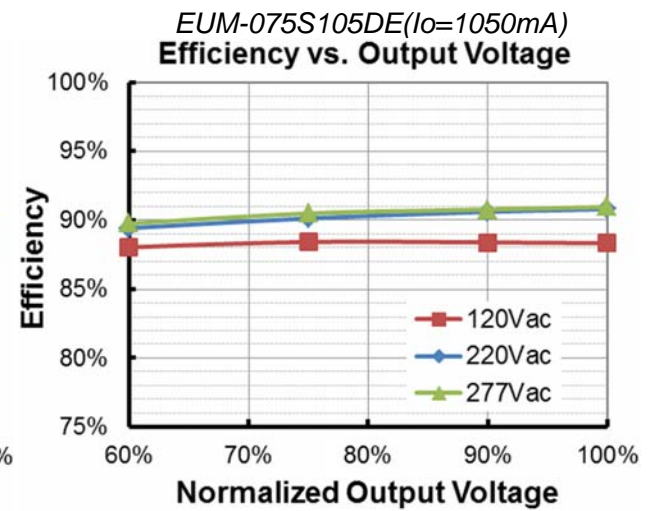
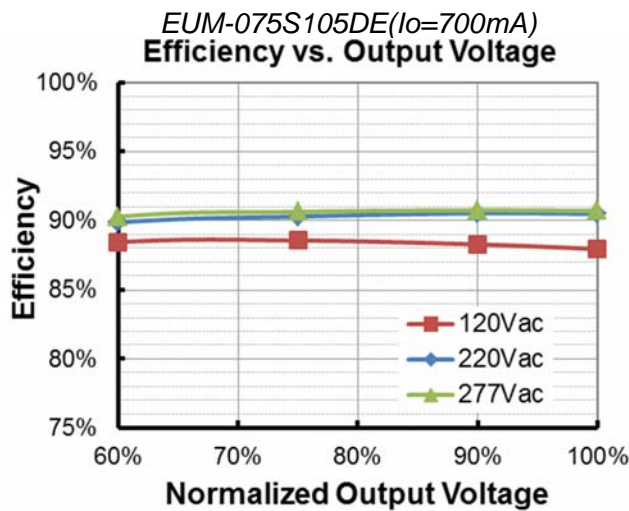
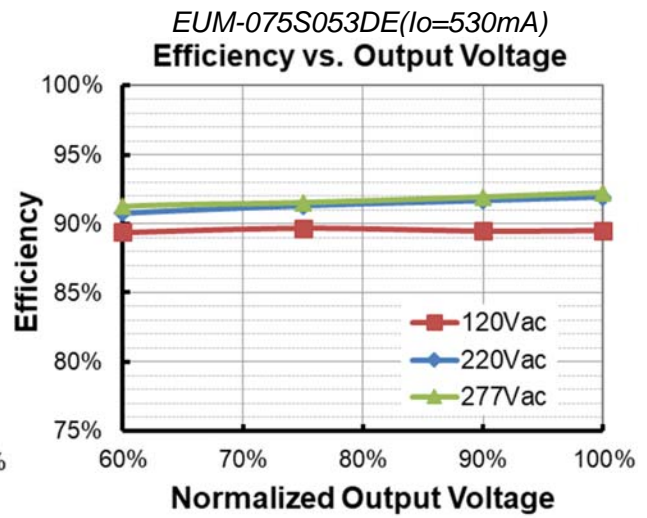
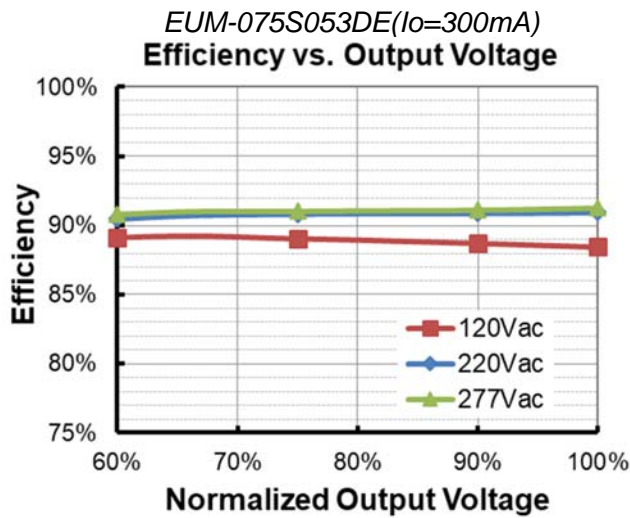

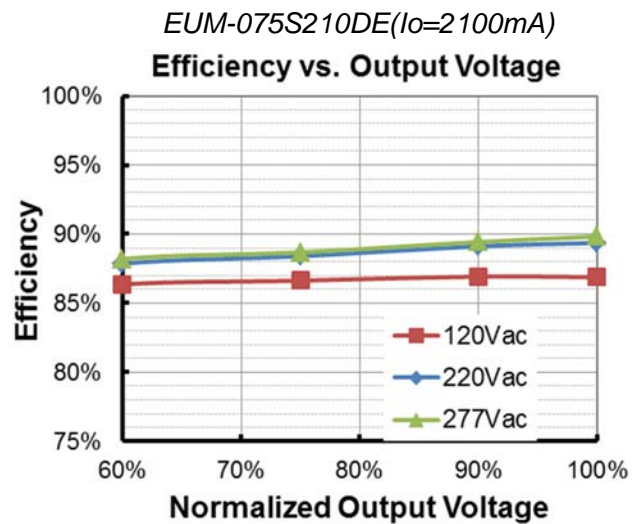
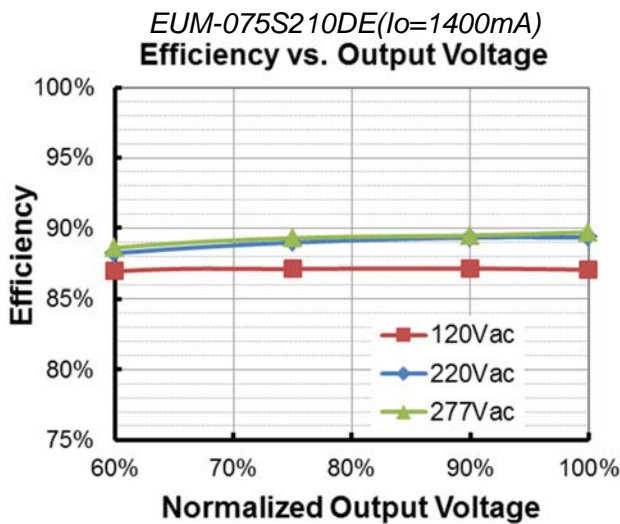
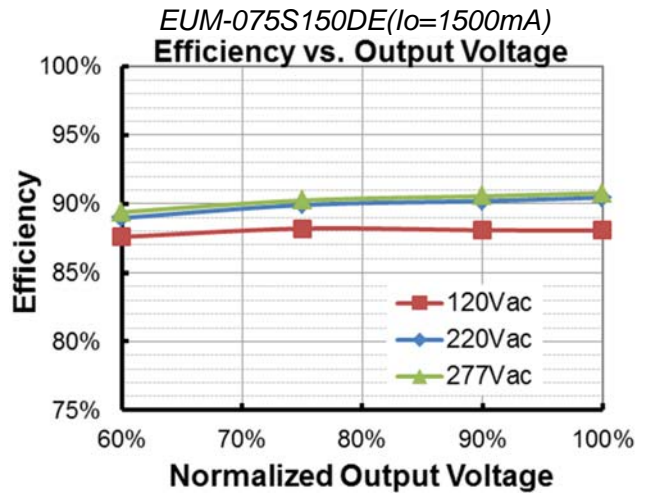
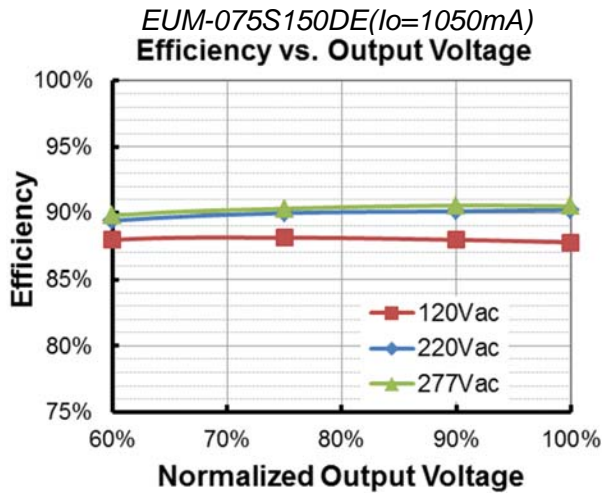

## Power Factor

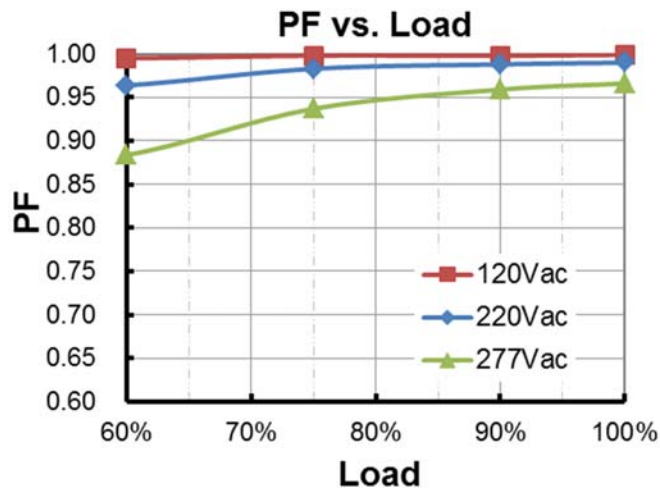



## Total Harmonic Distortion

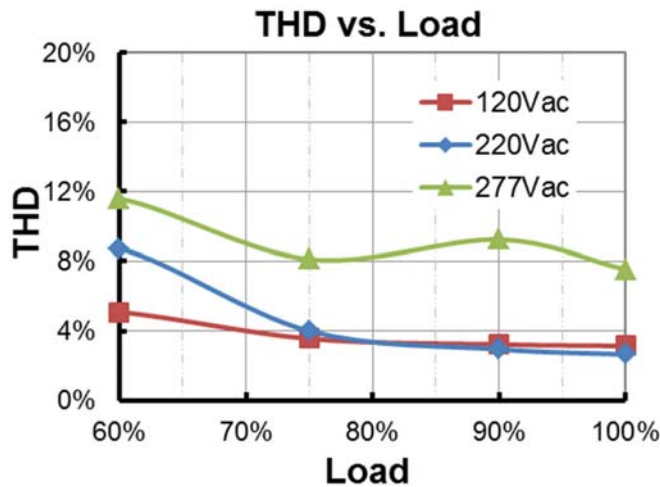

## Protection Functions

Parameter	Notes
Over Temperature Protection	Decreases output current, returning to normal after over temperature is removed.
Short Circuit Protection	Auto Recovery. No damage will occur when any output is short circuited. The output shall return to normal when the fault condition is removed.
Over Voltage Protection	Limits output voltage at no load and in case the normal voltage limit fails.

## Dimming

### ● 1-5V Dimming

The recommended implementation of the dimming control is provided below.

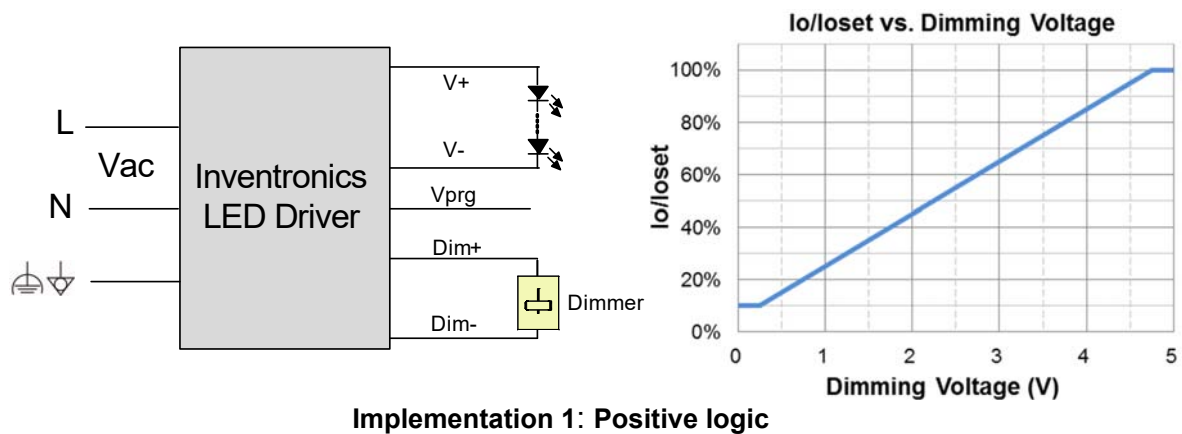

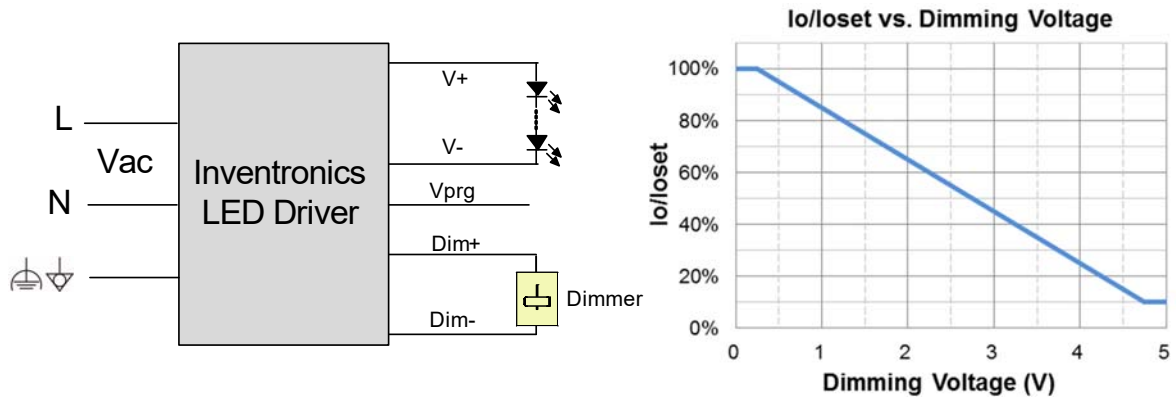

**Notes:**

1. Do NOT connect Dim- to the output V- or V+, otherwise the driver will not work properly.
2. The dimmer can also be replaced by an active 1-5V voltage source signal or passive components like zener.
3. When 1-5V negative logic dimming mode and Dim+ is open, the driver will output maximum current.

● **1-10V Dimming**

The recommended implementation of the dimming control is provided below.

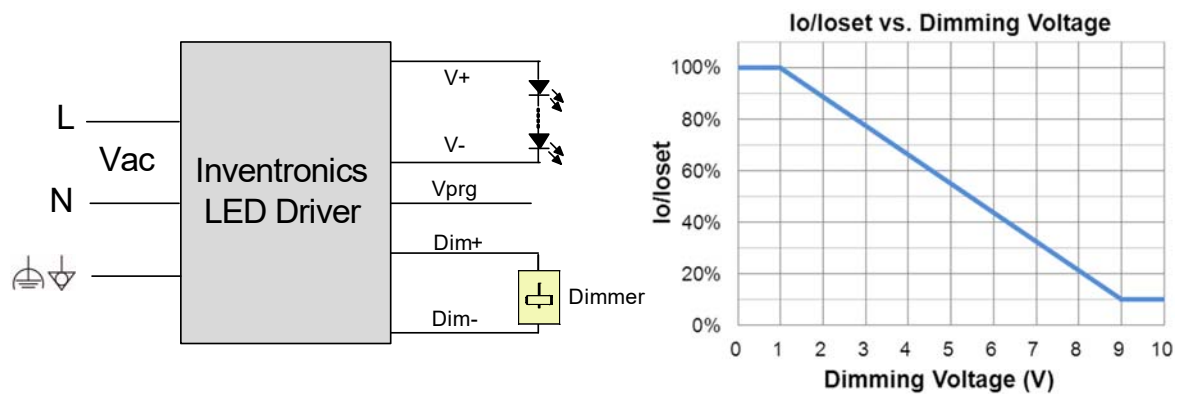
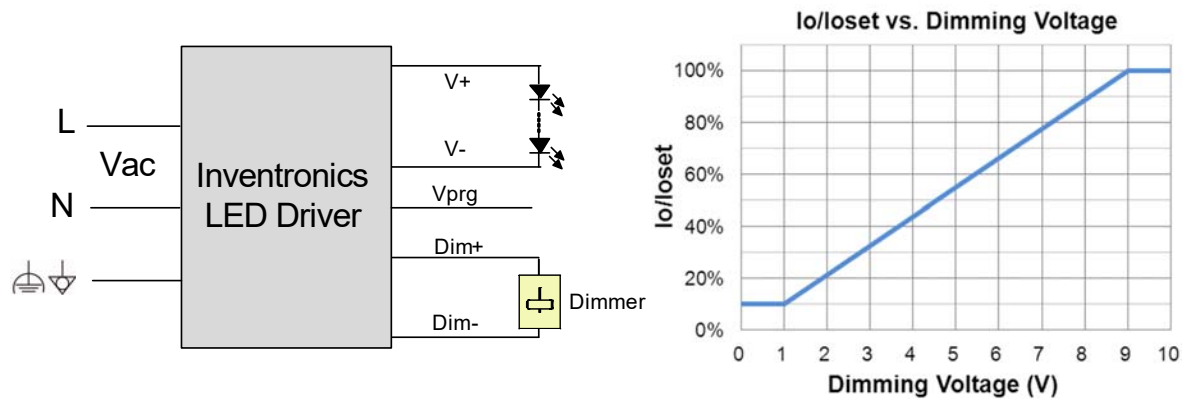

**Notes:**

1. Do NOT connect Dim- to the output V- or V+, otherwise the driver will not work properly
2. The dimmer can also be replaced by an active 1-10V voltage source signal or passive components like zener.
3. When 1-10V negative logic dimming mode and Dim+ is open, the driver will output minimum current.

● **10V PWM Dimming**

The recommended implementation of the dimming control is provided below.

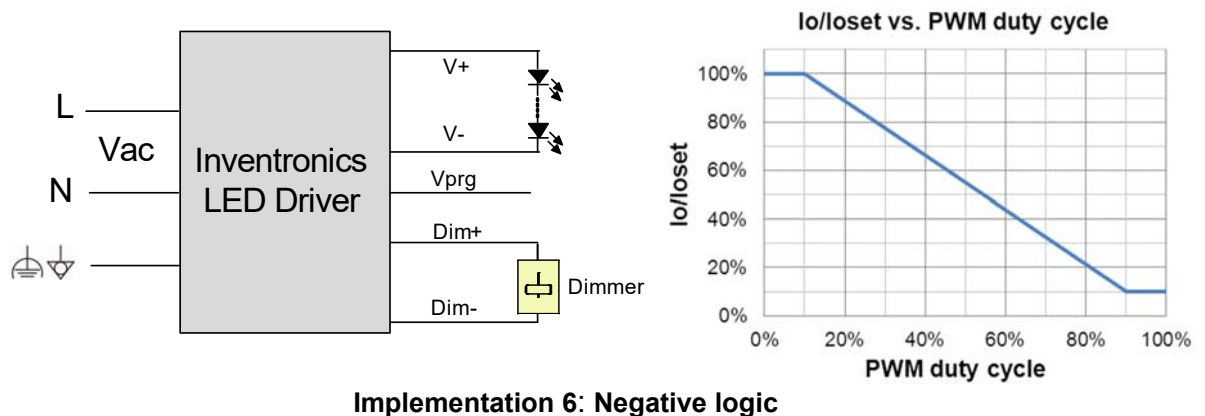
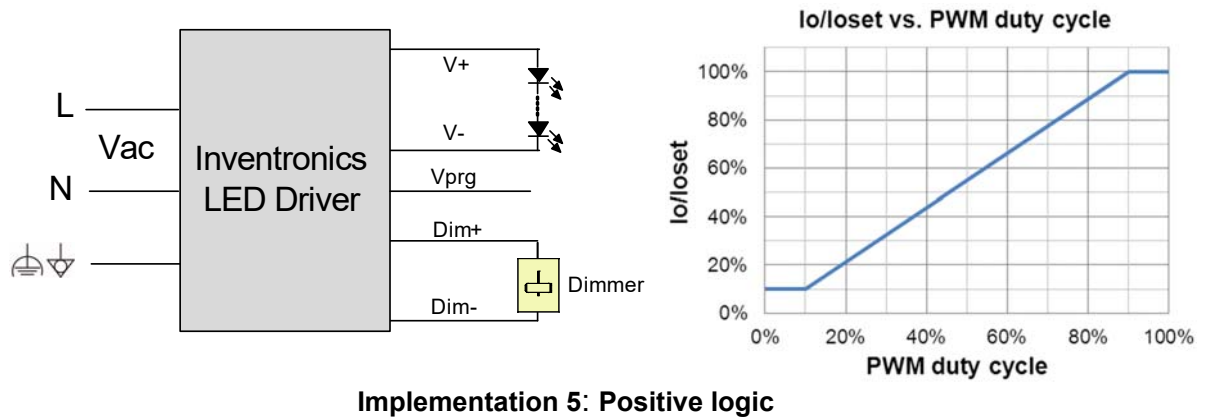

**Notes:**

1. Do NOT connect Dim- to the output V- or V+, otherwise the driver will not work properly
2. When 10V PWM negative logic dimming mode and Dim+ is open, the driver will output minimum current.

● **Time Dimming**

Time dimming control includes 3 kinds of modes, they are Self Adapting-Midnight, Self Adapting-Percentage and Traditional Timer.

- **Self Adapting-Midnight:** Automatically adjusts the dimming curve based on the on-time of past two days (if difference <15 minutes), assuming that the center point of the dimming curve is midnight local time.
- **Self Adapting-Percentage:** Automatically adjusts the on-time of each step by a constant percentage = (actual on-time for the past 2 days if difference <15 min) / (programmed on-time from the dimming curve).
- **Traditional Timer:** Follows the programmed timing curve after power on with no changes.

● **Output Lumen Compensation**

Output Lumen Compensation (OLC) may be used to maintain constant light output over the life of the LEDs by driving them at a reduced current when new, then gradually increasing the drive current over time to counteract LED lumen degradation.

**Programming Connection Diagram**

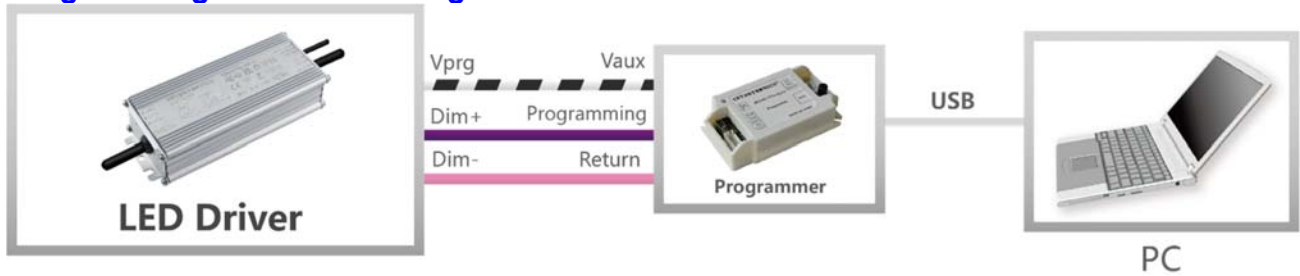

**Note:** The driver does not need to be powered on during the programming process.

● Please refer to [PRG-MUL2](#) (Programmer) datasheet for details.

**Mechanical Outline**

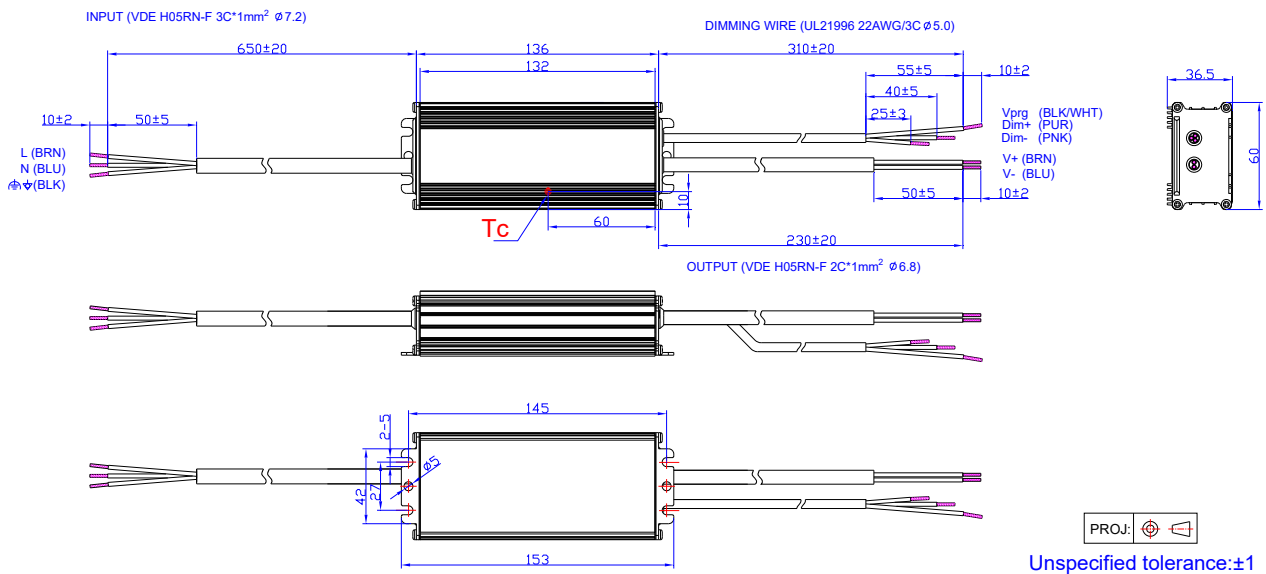

PROJ: Unspecified tolerance: ±1

**RoHS Compliance**

Our products comply with reference to RoHS Directive (EU) 2015/863 amending 2011/65/EU, calling for the elimination of lead and other hazardous substances from electronic products.

## Revision History

Change Date	Rev.	Description of Change		
		Item	From	To
2022-03-04	A	Datasheets Release	/	/
2023-06-09	B	Product Photograph	/	Updated
		Safety & EMC Compliance	/	Updated
		Dimming	/	Updated
		Programming Connection Diagram	/	Updated
		Mechanical Outline	/	Updated