

Features

- Full Power at Wide Output Current Range (Constant Power)
- Adjustable Output Current (AOC) with NFC
- DALI-2 Certified (Part 251, 252, 253)
- 3-Timer-Modes Dimmable
- Dim-to-Off with Standby Power $\leq 0.5W$
- Integrated Power Monitoring with High Accuracy up to $\pm 1\%$
- Output Lumen Compensation
- End-of-Life Indicator
- Input Surge Protection: DM 6kV, CM 10kV
- All-Around Protection: IUVP, IOVP, OVP, SCP, OTP
- IP66/IP67
UL Dry/Damp/Wet Location (ET/EG models)
- TYPE HL, for Use in a Class I, Division 2 Hazardous (Classified) Location (ET/EG models)
- Suitable for Luminaires with Protection Class I
- Suitable for Luminaires with Protection Class I and II (EE models)
- 5 Years Warranty

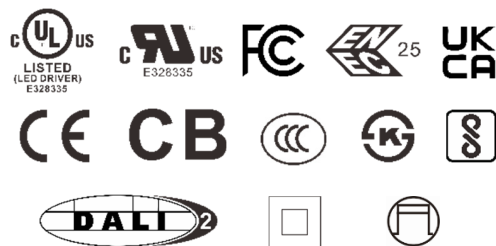

Description

The EUM-200SxxxEx series is a 200W, DALI-2, constant-current, NFC programmable and IP66/IP67 rated LED driver that operates from 90-305Vac input with excellent power factor. Created for intra-luminaire solutions and health monitoring applications, this family provides integrated AC power monitoring and dim-to-off functionality. The dimming control supports two-way communication via DALI-2. The high efficiency of these drivers and compact metal case enables them to run cooler, significantly improving reliability and extending product life. To ensure trouble-free operation, protection is provided against input surge, input under voltage, input over voltage, output over voltage, short circuit, and over temperature.

Models

| Adjustable Output Current Range (mA) | Full-Power Current Range (mA) ⁽¹⁾ | Default Output Current (mA) | Output Voltage Range (Vdc) | Max. Output Power (W) | Typical Efficiency ⁽²⁾ | Typical Power Factor | | Model Number ⁽³⁾⁽⁴⁾⁽⁵⁾ |
|--------------------------------------|--|-----------------------------|----------------------------|-----------------------|-----------------------------------|----------------------|--------|-----------------------------------|
| | | | | | | 120Vac | 220Vac | |
| 53-700 | 530-700 | 530 | 142-378 | 200 | 94.0% | 0.99 | 0.96 | EUM-200S070Ex |
| 70-1050 | 700-1050 | 700 | 95-286 | 200 | 94.0% | 0.99 | 0.96 | EUM-200S105Ex |
| 105-1500 | 1050-1500 | 1050 | 67-190 | 200 | 93.0% | 0.99 | 0.96 | EUM-200S150Ex |
| 180-2800 | 1800-2800 | 2100 | 36-111 | 200 | 93.0% | 0.99 | 0.96 | EUM-200S280Ex ⁽⁶⁾ |
| 350-5600 | 3500-5600 | 4200 | 18-57 | 200 | 92.5% | 0.99 | 0.96 | EUM-200S560Ex ⁽⁶⁾ |

- Notes:** (1) Output current range with constant power at 200W
 (2) Measured at 100% load and 220Vac input (see below "General Specifications" for details).
 (3) Certified input voltage range: UL, FCC 100-277Vac; otherwise 100-240Vac.
 (4) All the models are certificated to KS, except EUM-200S070Ex and EUM-200S105Ex.
 (5) x = G are UL Recognized, ENEC and CCC, etc. models; x = T are UL Class P models; x = E are Class II models with ENEC, etc. x = B are BIS models. See below "Mechanical Outline" for details.
 (6) SELV output.

I-V Operation Area

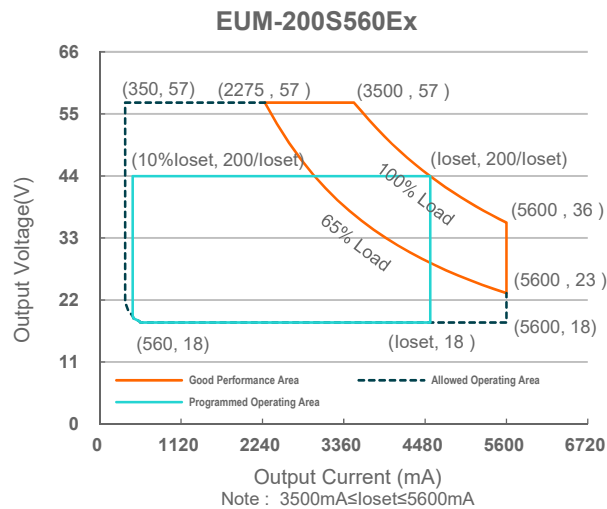
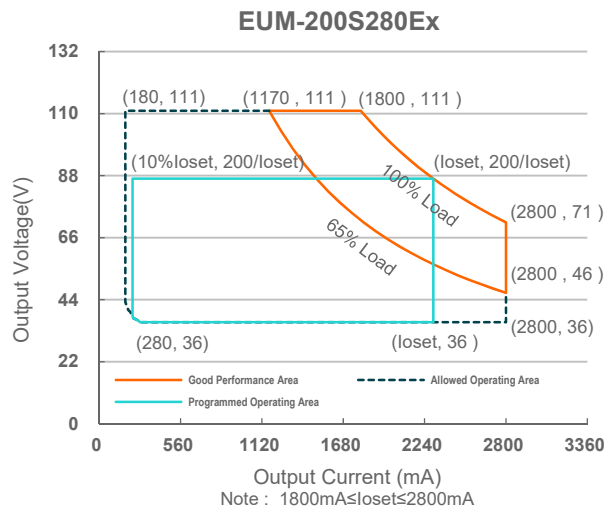
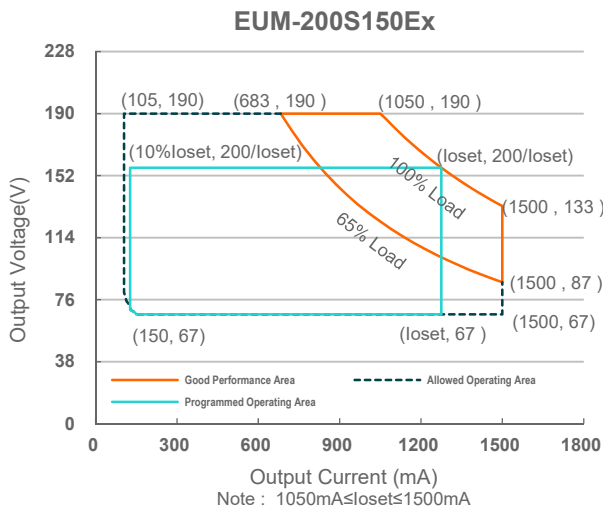
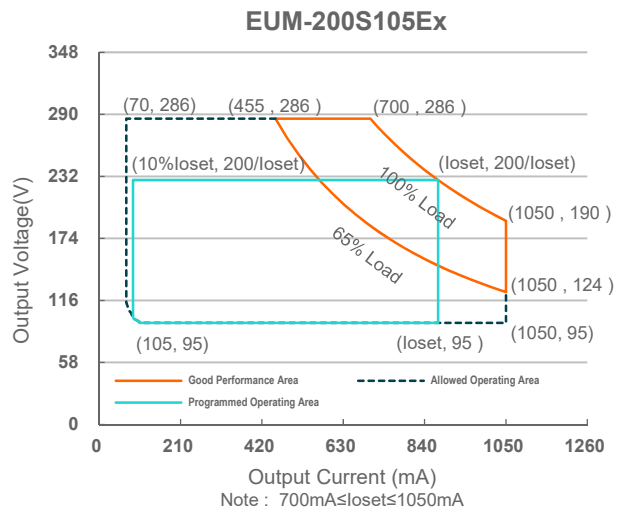
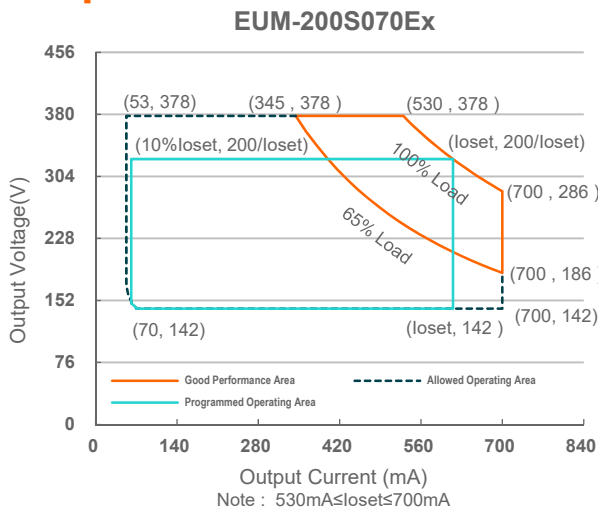

Input Specifications

| Parameter | Min. | Typ. | Max. | Notes |
|----------------------------------|---------|------|-----------------------|---|
| Input AC Voltage | 90 Vac | - | 305 Vac | |
| Input DC Voltage | 127 Vdc | - | 300 Vdc | |
| Input Frequency | 47 Hz | - | 63 Hz | |
| Leakage Current | - | - | 0.75 MIU | UL 8750; 277Vac/60Hz |
| | - | - | 0.70 mA | IEC 60598-1; 240Vac/60Hz |
| Input AC Current | - | - | 2.11 A | Measured at 100% load and 120 Vac input. |
| | - | - | 1.12 A | Measured at 100% load and 220 Vac input. |
| Inrush Current(I ² t) | - | - | 4.01 A ² s | At 220Vac input, 25°C cold start, duration=840 μs, 10%I _{pk} -10%I _{pk} . |
| PF | 0.9 | - | - | At 100-277Vac, 50-60Hz, 65%-100% load (130-200W) |
| THD | - | - | 20% | |
| THD | - | - | 10% | At 220-240Vac, 50-60Hz, 75%-100% load (150-200W) |

Output Specifications

| Parameter | Min. | Typ. | Max. | Notes |
|--|----------|---------------------|----------------------|---|
| Output Current Tolerance | -5%loset | - | 5%loset | At 100% load condition |
| Output Current Setting(loset) Range | | | | |
| EUM-200S070Ex | 53 mA | - | 700 mA | |
| EUM-200S105Ex | 70 mA | - | 1050 mA | |
| EUM-200S150Ex | 105 mA | - | 1500 mA | |
| EUM-200S280Ex | 180 mA | - | 2800 mA | |
| EUM-200S560Ex | 350 mA | - | 5600 mA | |
| Output Current Setting Range with Constant Power | | | | |
| EUM-200S070Ex | 530 mA | - | 700 mA | |
| EUM-200S105Ex | 700 mA | - | 1050 mA | |
| EUM-200S150Ex | 1050 mA | - | 1500 mA | |
| EUM-200S280Ex | 1800 mA | - | 2800 mA | |
| EUM-200S560Ex | 3500 mA | - | 5600 mA | |
| Total Output Current Ripple (pk-pk) | - | 5%I _{omax} | 10%I _{omax} | At 100% load condition. 20 MHz BW |
| Output Current Ripple at < 200 Hz (pk-pk) | - | 2%I _{omax} | - | At 100% load condition. Only this component of ripple is associated with visible flicker. |
| Startup Overshoot Current | - | - | 10%I _{omax} | At 100% load condition |
| No Load Output Voltage | | | | |
| EUM-200S070Ex | - | - | 420 V | |
| EUM-200S105Ex | - | - | 320 V | |
| EUM-200S150Ex | - | - | 210 V | |
| EUM-200S280Ex | - | - | 120 V | |
| EUM-200S560Ex | - | - | 65 V | |

Output Specifications (Continued)

| Parameter | Min. | Typ. | Max. | Notes |
|--|------|----------|-------|--|
| Line Regulation | - | - | ±0.5% | Measured at 100% load |
| Load Regulation | - | - | ±3.0% | |
| Turn-on Delay Time | - | - | 0.5 s | Measured at all dimming modes except DALI-2, and 120-277Vac input, 65%-100% Load |
| | - | - | 1.0 s | Measured at DALI-2 dimming mode, and 120-277Vac input, 65%-100% Load |
| Temperature Coefficient of Is _o set | - | 0.03%/°C | - | Case temperature = 0°C~T _c max |

General Specifications

| Parameter | Min. | Typ. | Max. | Notes | |
|------------------------------|-------|-------|------|--|--|
| Efficiency at 120 Vac input: | | | | | |
| EUM-200S070Ex | | | | | |
| I _o = 530 mA | 89.0% | 91.0% | - | | |
| I _o = 700 mA | 89.5% | 91.5% | - | | |
| EUM-200S105Ex | | | | | |
| I _o = 700 mA | 89.0% | 91.0% | - | | |
| I _o =1050 mA | 89.5% | 91.5% | - | | |
| EUM-200S150Ex | | | | | |
| I _o =1050 mA | 88.5% | 90.5% | - | Measured at 100% load and steady-state temperature in 25°C ambient; (Efficiency will be about 2.0% lower if measured immediately after startup.) | |
| I _o =1500 mA | 88.5% | 90.5% | - | | |
| EUM-200S280Ex | | | | | |
| I _o =1800 mA | 88.0% | 90.0% | - | | |
| I _o =2800 mA | 87.5% | 89.5% | - | | |
| EUM-200S560Ex | | | | | |
| I _o =3500 mA | 88.0% | 90.0% | - | | |
| I _o =5600 mA | 87.5% | 89.5% | - | | |
| Efficiency at 220 Vac input: | | | | | |
| EUM-200S070Ex | | | | | |
| I _o = 530 mA | 92.0% | 94.0% | - | | Measured at 100% load and steady-state temperature in 25°C ambient; (Efficiency will be about 2.0% lower if measured immediately after startup.) |
| I _o = 700 mA | 92.0% | 94.0% | - | | |
| EUM-200S105Ex | | | | | |
| I _o = 700 mA | 91.5% | 93.5% | - | | |
| I _o =1050 mA | 92.0% | 94.0% | - | | |
| EUM-200S150Ex | | | | | |
| I _o =1050 mA | 91.0% | 93.0% | - | | |
| I _o =1500 mA | 91.0% | 93.0% | - | | |
| EUM-200S280Ex | | | | | |
| I _o =1800 mA | 91.0% | 93.0% | - | | |
| I _o =2800 mA | 91.0% | 93.0% | - | | |
| EUM-200S560Ex | | | | | |
| I _o =3500 mA | 90.5% | 92.5% | - | | |
| I _o =5600 mA | 90.0% | 92.0% | - | | |

General Specifications (Continued)

| Parameter | Min. | Typ. | Max. | Notes |
|---|---------------------------------------|---------------|-------|--|
| Efficiency at 277 Vac input: EUM-200S070Ex | | | | Measured at 100% load and steady-state temperature in 25°C ambient; (Efficiency will be about 2.0% lower if measured immediately after startup.) |
| I _o = 530 mA | 92.0% | 94.0% | - | |
| I _o = 700 mA | 92.5% | 94.5% | - | |
| EUM-200S105Ex | | | | |
| I _o = 700 mA | 92.0% | 94.0% | - | |
| I _o =1050 mA | 92.0% | 94.0% | - | |
| EUM-200S150Ex | | | | |
| I _o =1050 mA | 91.5% | 93.5% | - | |
| I _o =1500 mA | 91.5% | 93.5% | - | |
| EUM-200S280Ex | | | | |
| I _o =1800 mA | 91.5% | 93.5% | - | |
| I _o =2800 mA | 91.5% | 93.5% | - | |
| EUM-200S560Ex | | | | |
| I _o =3500 mA | 91.0% | 93.0% | - | |
| I _o =5600 mA | 90.5% | 92.5% | - | |
| Power Monitoring Accuracy | -1% | - | 1% | Measured at 220Vac input and 100% load |
| Standby Power | - | - | 0.5 W | Measured at 230Vac/50Hz; Dimming off |
| MTBF | - | 205,000 Hours | - | Measured at 220Vac input, 80%Load and 25°C ambient temperature (MIL-HDBK-217F) |
| Lifetime | - | 104,000 Hours | - | Measured at 220Vac input, 80%Load and 70°C case temperature; See lifetime vs. Tc curve for the details |
| Operating Case Temperature for Safety T _{c_s} | -40°C | - | +90°C | |
| Operating Case Temperature for Warranty T _{c_w} | -40°C | - | +80°C | Case temperature for 5 years warranty Humidity: 10% RH to 95% RH |
| Storage Temperature | -40°C | - | +85°C | Humidity: 5%RH to 95%RH |
| Dimensions Inches (L × W × H) Millimeters (L × W × H) | 6.73 × 2.52 × 1.44 171 × 64 × 36.5 | | | With mounting ear 7.40 × 2.52 × 1.44 188 × 64 × 36.5 |
| Net Weight | - | 815 g | - | |

Dimming Specifications

| Parameter | Min. | Typ. | Max. | Notes |
|-------------------|--------|------|--------|-------|
| DA, DA High Level | 9.5 V | 16 V | 22.5 V | |
| DA, DA Low Level | -6.5 V | 0 V | 6.5 V | |
| DA, DA Current | 0 mA | - | 2 mA | |

Dimming Specifications (Continued)

| Parameter | | Min. | Typ. | Max. | Notes |
|----------------------|---|--|------|-------|--|
| Dimming Output Range | EUM-200S070Ex EUM-200S105Ex EUM-200S150Ex EUM-200S280Ex EUM-200S560Ex | 10%loset | - | loset | 530 mA ≤ loset ≤ 700 mA 700 mA ≤ loset ≤ 1050 mA 1050 mA ≤ loset ≤ 1500 mA 1800 mA ≤ loset ≤ 2800 mA 3500 mA ≤ loset ≤ 5600 mA |
| | EUM-200S070Ex EUM-200S105Ex EUM-200S150Ex EUM-200S280Ex EUM-200S560Ex | 53 mA 70 mA 105 mA 180 mA 350 mA | - | loset | 53 mA ≤ loset < 530 mA 70 mA ≤ loset < 700 mA 105 mA ≤ loset < 1050 mA 180 mA ≤ loset < 1800 mA 350 mA ≤ loset < 3500 mA |

Safety & EMC Compliance

| Safety Category | Standard |
|--|---|
| UL/CUL | UL 8750,CAN/CSA-C22.2 No. 250.13 |
| ENEC | EN 61347-1 ⁽¹⁾ , EN 61347-2-13 |
| UKCA | BS EN 61347-1 ⁽¹⁾ , BS EN 61347-2-13 BS EN 301 489-1 BS EN 301 489-3 BS EN 300 330 BS EN 62479/BS EN 50663/BS EN 50665/BS EN 50364 |
| CE | EN 61347-1 ⁽¹⁾ , EN 61347-2-13 EN 301 489-1 EN 301 489-3 EN 300 330 EN 62479/EN 50663/EN 50665/EN 50364 |
| CB | IEC 61347-1 ⁽¹⁾ , IEC 61347-2-13 |
| CCC | GB 19510.1, GB 19510.14 |
| KS | KS C 7655 |
| BIS | IS 15885(Part2/Sec13) |
| Performance | Standard |
| ENEC | EN IEC 62384 |
| EMI Standards | Notes |
| BS EN/EN IEC 55015/GB/T 17743 ⁽²⁾ | Conducted emission Test &Radiated emission Test |
| BS EN/EN IEC 61000-3-2/GB 17625.1 | Harmonic current emissions |
| BS EN/EN 61000-3-3 | Voltage fluctuations & flicker |
| FCC Part 15 ⁽²⁾ | ANSI C63.4 Class B |
| | This device complies with Part 15 of the FCC Rules. Operation is subject to the following two conditions: [1] this device may not cause harmful interference, and [2] this device must accept any interference received, including interference that may cause undesired operation. |

Safety & EMC Compliance (Continued)

| EMS Standards | Notes |
|-----------------------|---|
| BS EN/EN 61000-4-2 | Electrostatic Discharge (ESD): 8 kV air discharge, 4 kV contact discharge |
| BS EN/EN 61000-4-3 | Radio-Frequency Electromagnetic Field Susceptibility Test-RS |
| BS EN/EN 61000-4-4 | Electrical Fast Transient / Burst-EFT |
| BS EN/EN 61000-4-5 | Surge Immunity Test: AC Power Line: Differential Mode 6 kV, Common Mode 10 kV |
| BS EN/EN 61000-4-6 | Conducted Radio Frequency Disturbances Test-CS |
| BS EN/EN 61000-4-8 | Power Frequency Magnetic Field Test |
| BS EN/EN 61000-4-11 | Voltage Dips |
| BS EN/EN 61547 | Electromagnetic Immunity Requirements Applies To Lighting Equipment |
| DALI-2 Standards | Notes |
| DALI-2 ⁽³⁾ | IEC 62386-101, -102 & -207 |

Notes: (1) EE models meet the requirements for EN/BS EN/IEC 61347-1(Class II), when the driver is energized, the allowed leakage current is perceptible but harmless.

(2) This LED driver meets the EMI specifications above, but EMI performance of a luminaire that contains it depends also on the other devices connected to the driver and on the fixture itself.

(3) DALI Parts: 101, 102, 207, 251, 252, 253.

Derating

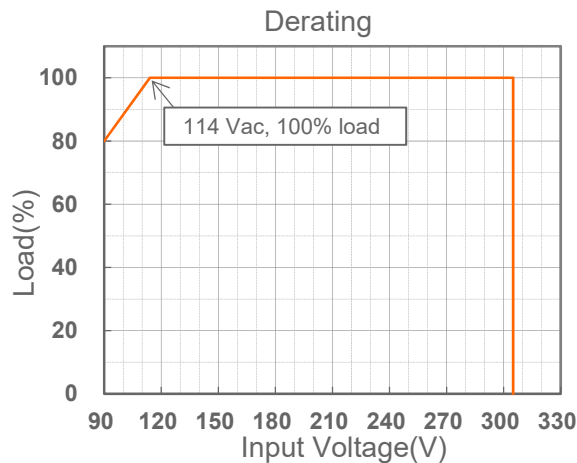

Lifetime vs. Case Temperature

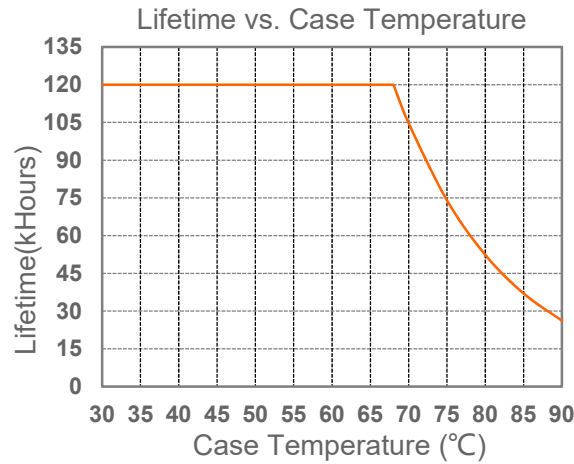

Inrush Current Waveform

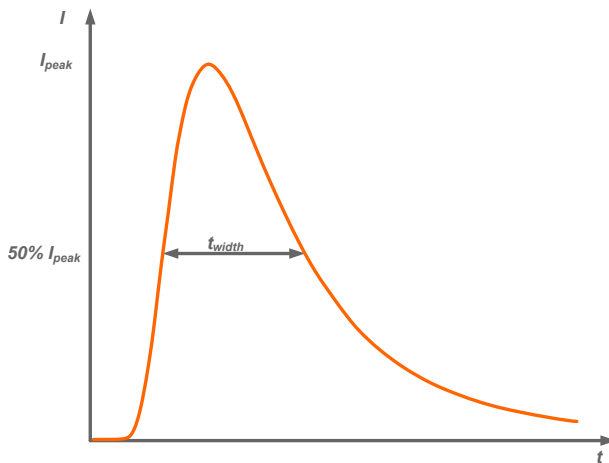

| Input AC Voltage | I_{peak} | t_{width} (@ 50% I_{peak}) |
|------------------|------------|------------------------------------|
| 220Vac | 79.8A | 336 μ s |

Efficiency vs. Load

EUM-200S070Ex ($I_o=530mA$)
Efficiency vs. Output Voltage

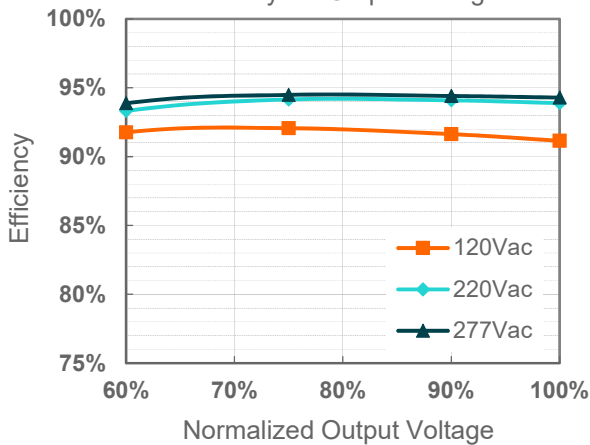

EUM-200S070Ex ($I_o=700mA$)
Efficiency vs. Output Voltage

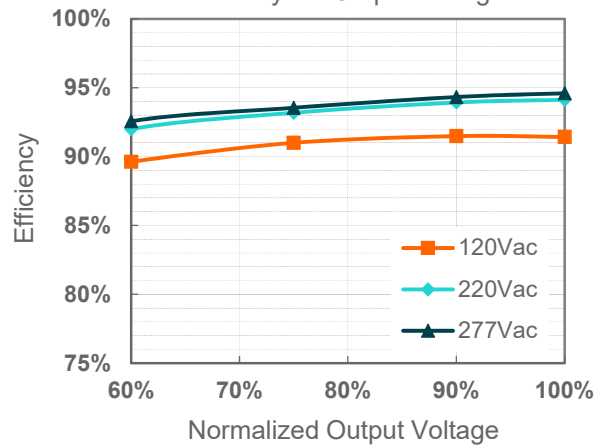

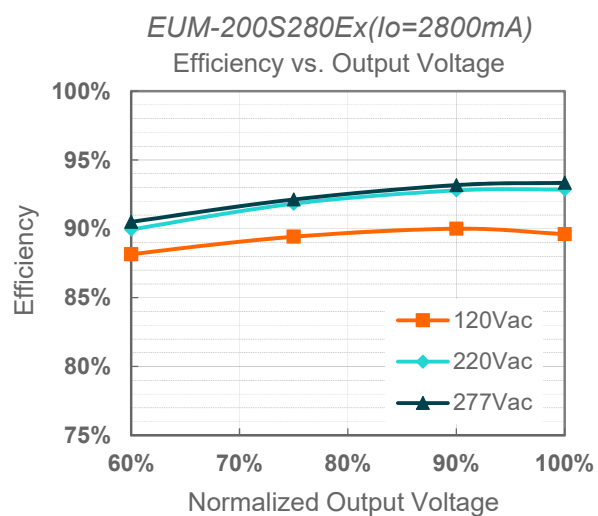
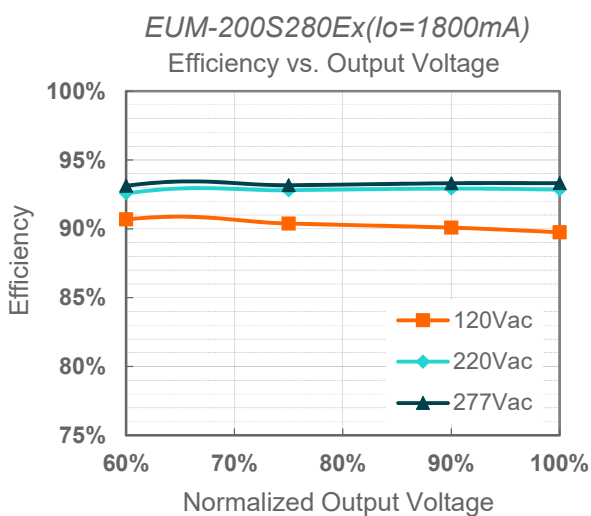
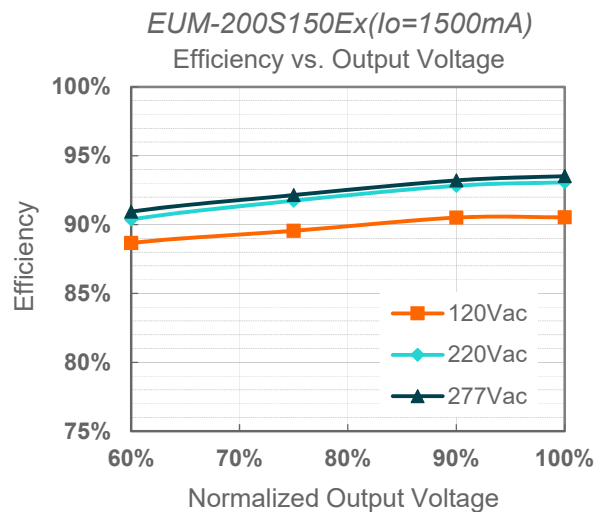
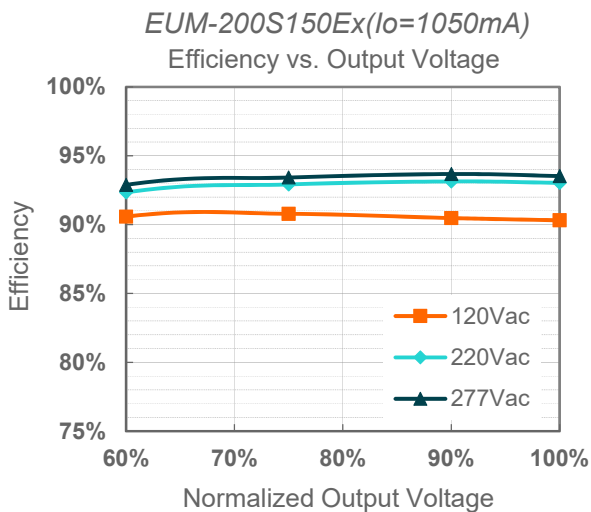
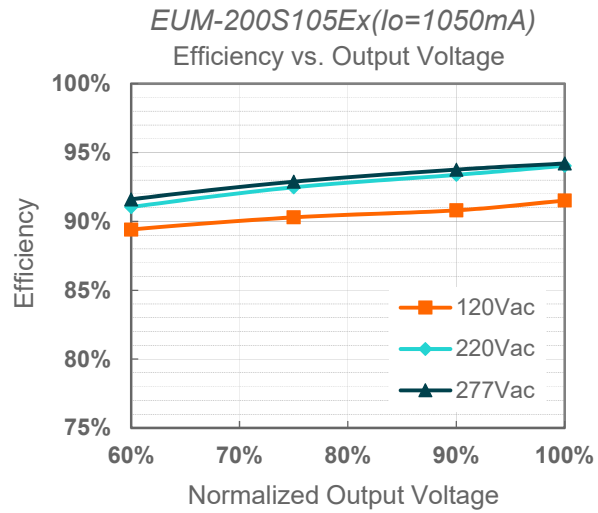
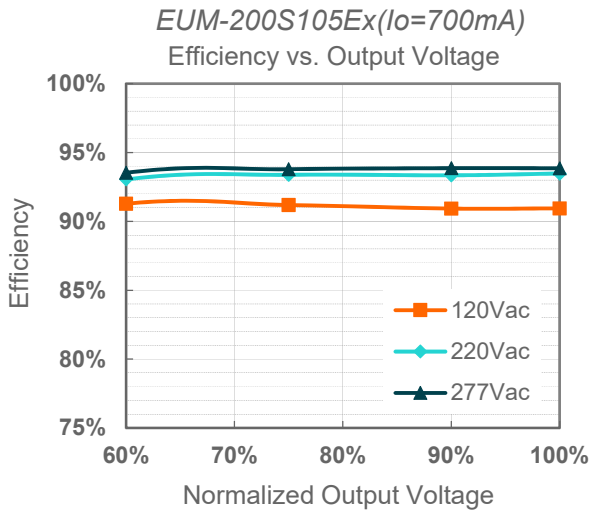

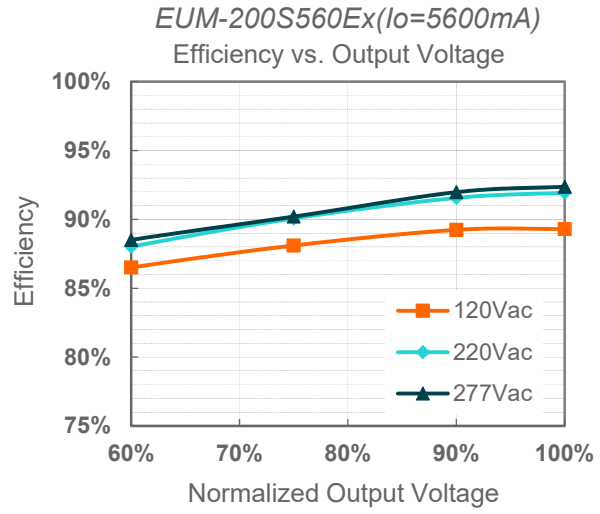
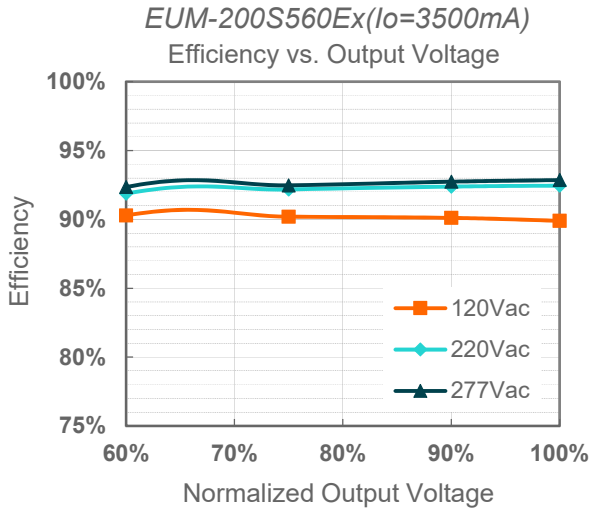

Power Factor

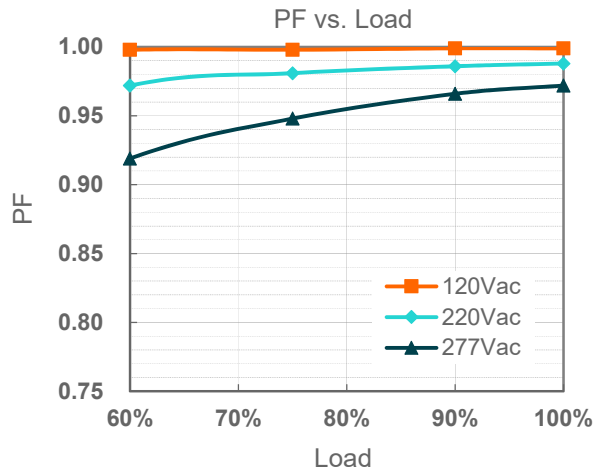

Total Harmonic Distortion

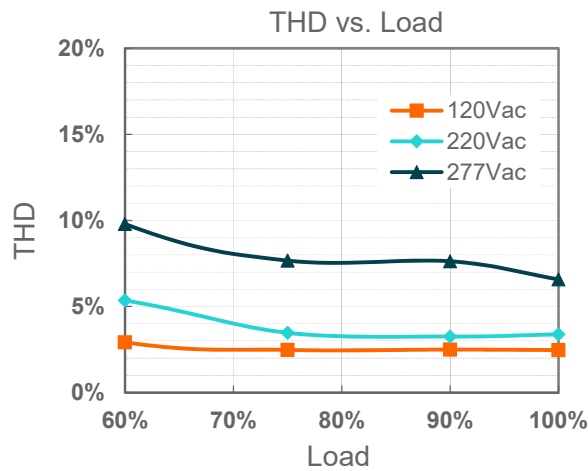

Protection Functions

| Parameter | | Min. | Typ. | Max. | Notes |
|---------------------------------------|--------------------------------|--|---------|---------|--|
| Over Voltage Protection | | Limits output voltage at no load and in case the normal voltage limit fails. | | | |
| Short Circuit Protection | | Auto Recovery. No damage will occur when any output is short circuited. The output shall return to normal when the fault condition is removed. | | | |
| Over Temperature Protection | | Decreases output current, returning to normal after over temperature is removed. | | | |
| Input Under Voltage Protection (IUVP) | Input Under Voltage Protection | 70 Vac | 80 Vac | 90 Vac | Turn off the output when the input voltage falls below protection voltage. |
| | Input Under Voltage Recovery | 75 Vac | 85 Vac | 95 Vac | Auto Recovery. The driver will restart when the input voltage exceeds recovery voltage. |
| Input Over Voltage Protection | Input Over Voltage Protection | 310 Vac | 320 Vac | 330 Vac | Turn off the output when the input voltage exceeds protection voltage. |
| | Input Over Voltage Recovery | 300 Vac | 310 Vac | 320 Vac | Auto Recovery. The driver will restart when the input voltage falls below recovery voltage. |
| | Max. of Input Over Voltage | - | - | 350 Vac | The driver can survive stabilized input over voltage conditions up to 350Vac for a total of 8 hours. |

● Input Under Voltage Protection Diagram

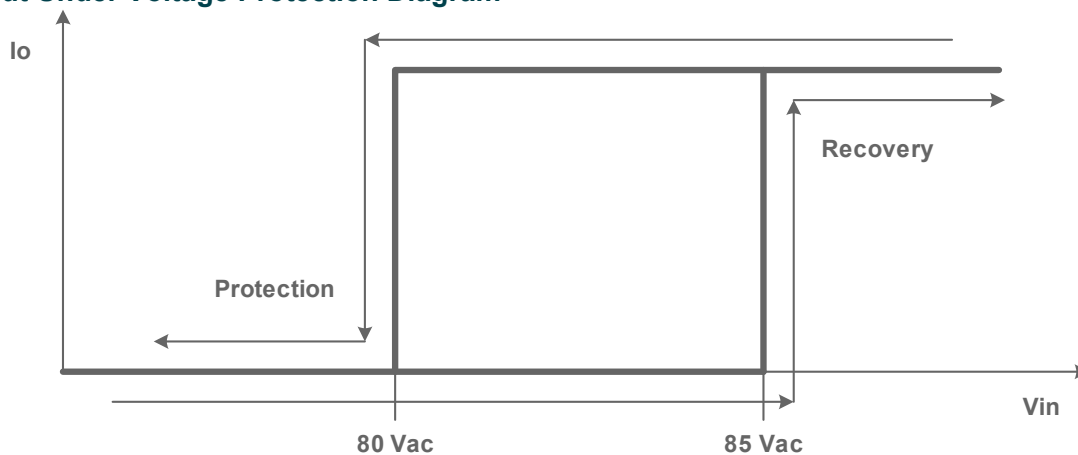

● Input Over Voltage Protection Diagram

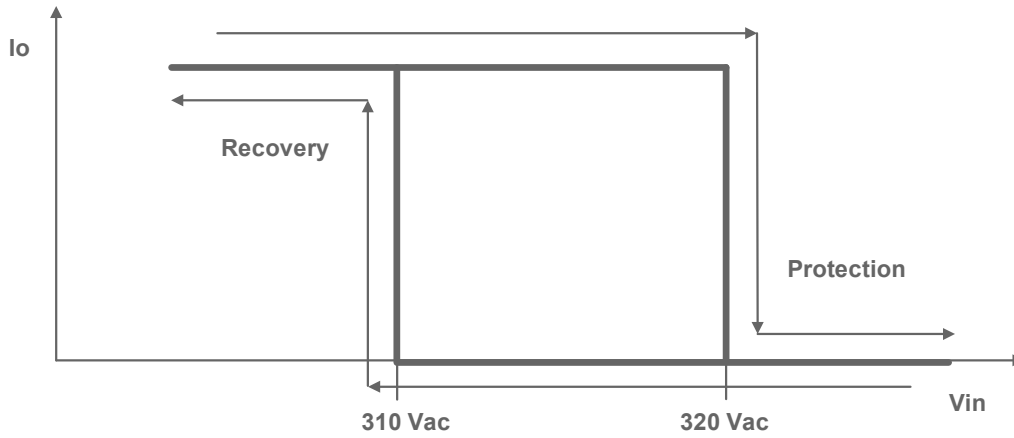

Dimming

● DALI-2 Dimming

The recommended implementation of the dimming control is provided below.

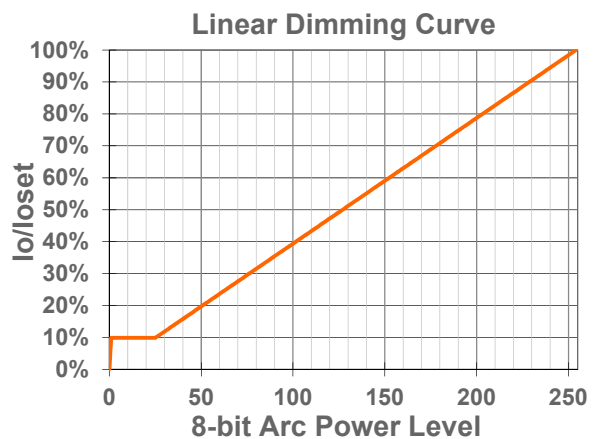
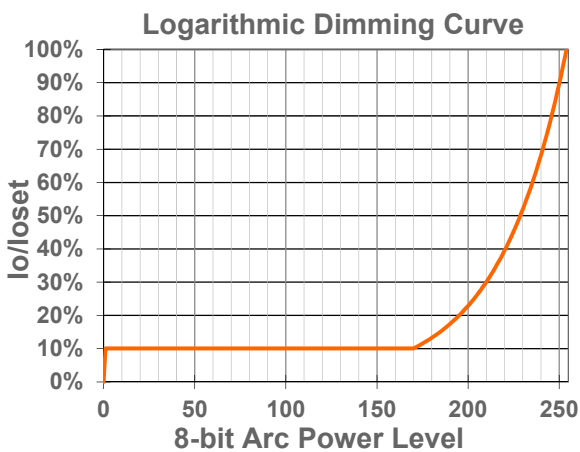
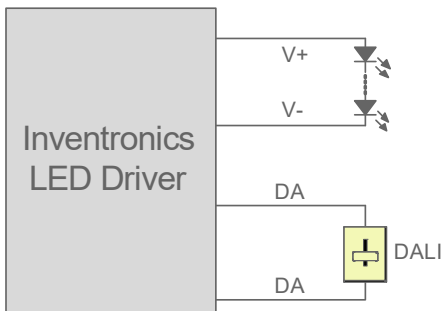

Implementation: DALI-2 Dimming

● Time Dimming

Time dimming control includes 3 kinds of modes, they are Self Adapting-Midnight, Self Adapting-Percentage and Traditional Timer.

- **Self Adapting-Midnight:** Automatically adjusts the dimming curve based on the on-time of past two days (if difference <15 minutes), assuming that the center point of the dimming curve is midnight local time.
- **Self Adapting-Percentage:** Automatically adjusts the on-time of each step by a constant percentage = (actual on-time for the past 2 days if difference <15 min) / (programmed on-time from the dimming curve).
- **Traditional Timer:** Follows the programmed timing curve after power on with no changes.

● Output Lumen Compensation

Output Lumen Compensation (OLC) may be used to maintain constant light output over the life of the LEDs by driving them at a reduced current when new, then gradually increasing the drive current over time to counteract LED lumen degradation.

● End Of Life

End-of-Life (EOL) is providing a visual notification to a user that the LED module has reached the end of manufacturer-specified life and that the replacement is recommended. Once active, an indication is given at each power-up of the driver, which the driver indicates this through a lower light output during the first 1 minute before normal operation is continued.

Programming Connection Diagram

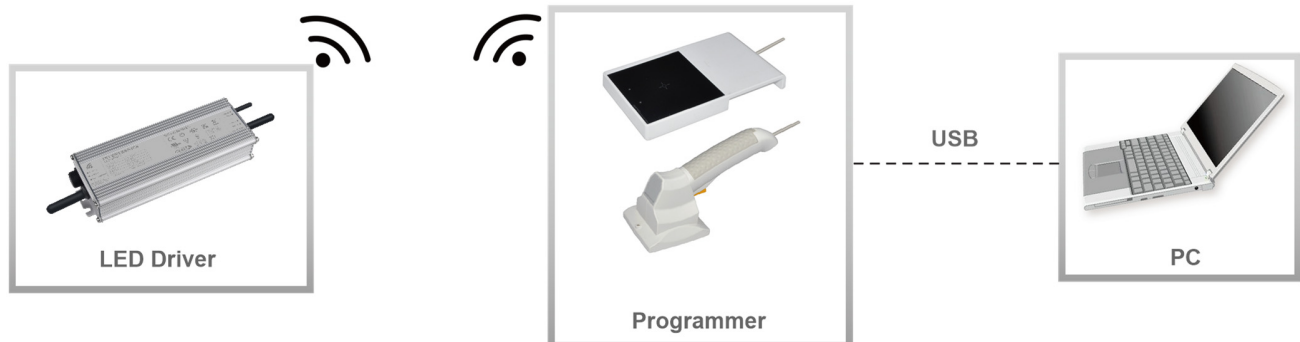

Note: The driver does not need to be powered on during the programming process.

- Please refer to [PRG-NFC-H](#) or [PRG-NFC-D2](#) (Programmer) datasheet for details.

Mechanical Outline

EUM-200SxxxEG

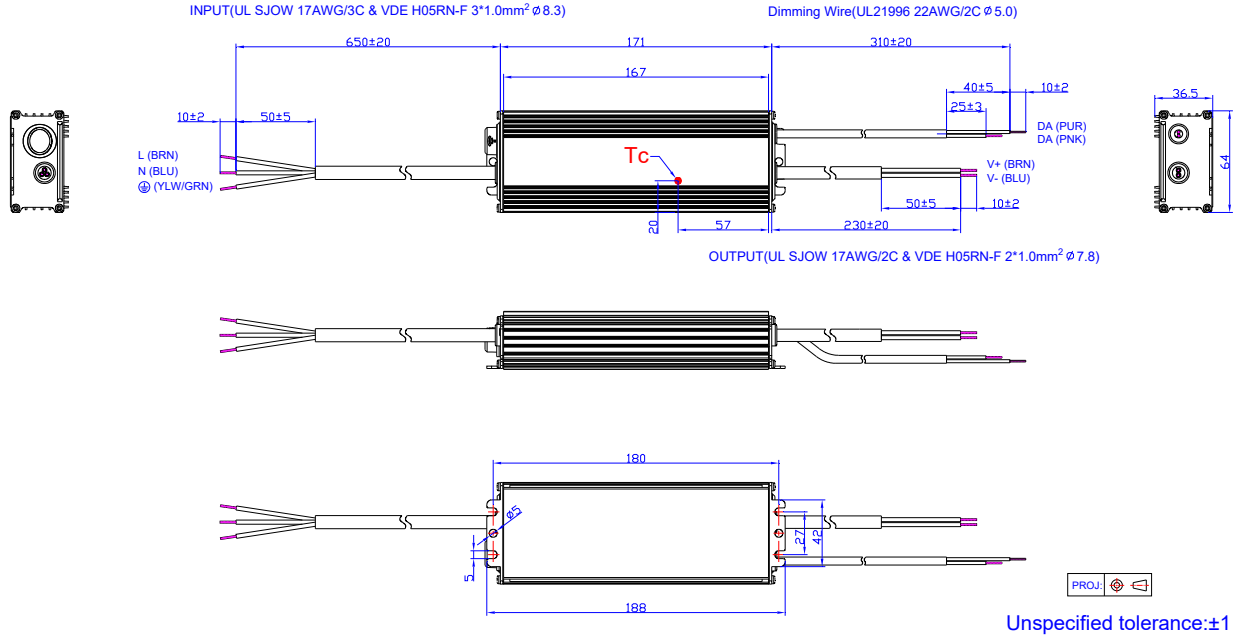

EUM-200SxxxET

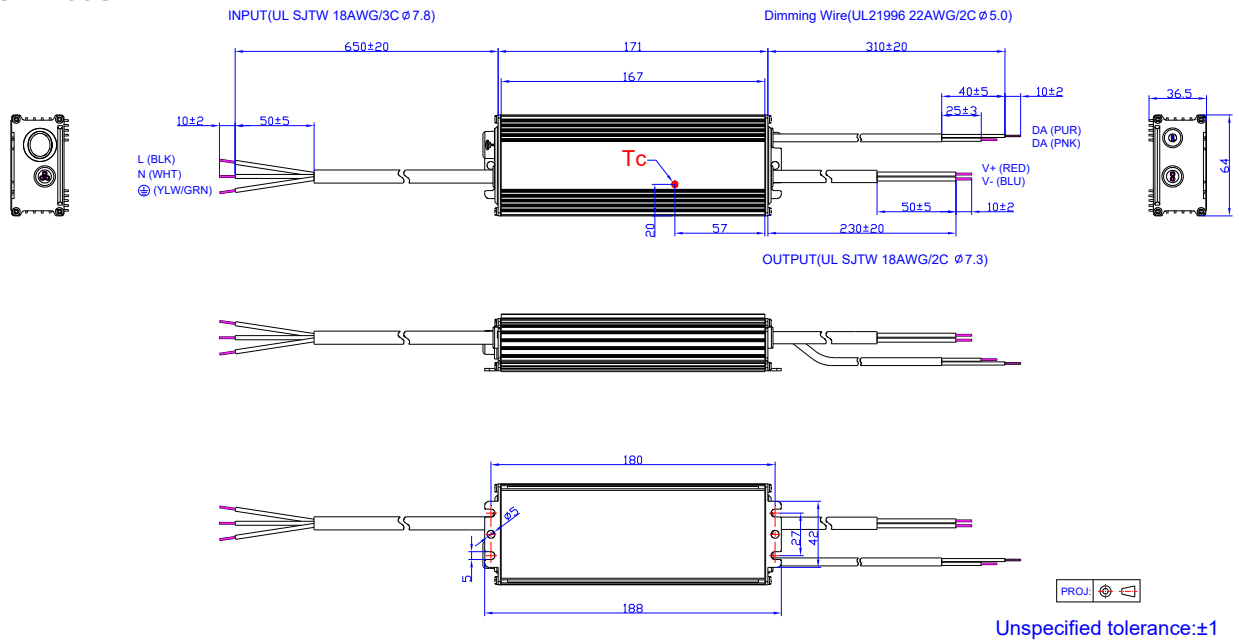

EUM-200SxxxEE

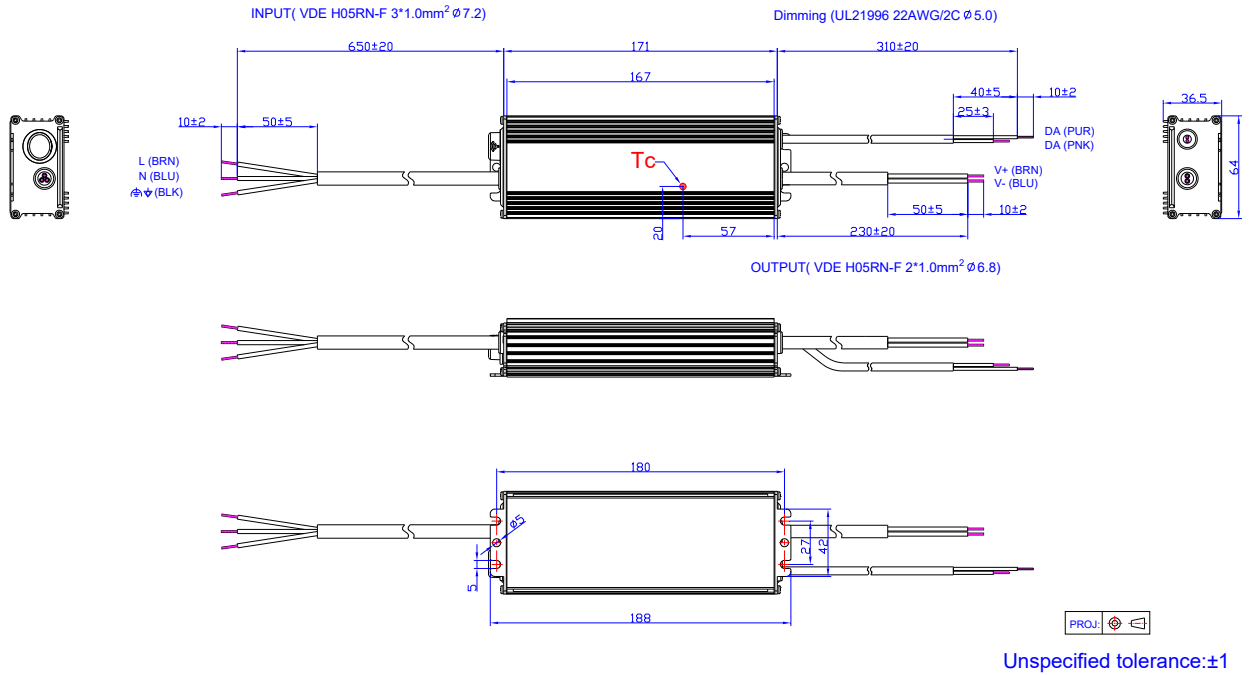

EUM-200SxxxEB

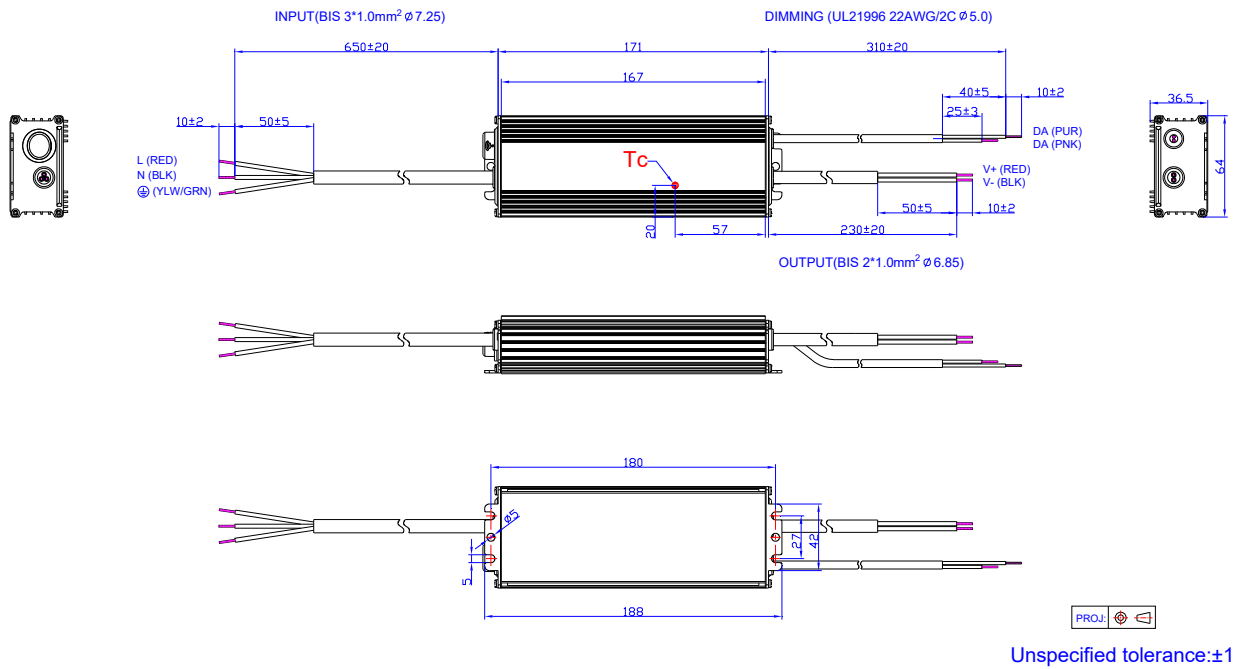

RoHS Compliance

Our products comply with reference to RoHS Directive (EU) 2015/863 amending 2011/65/EU, calling for the elimination of lead and other hazardous substances from electronic products.

Revision History

| Change Date | Rev. | Description of Change | | |
|-------------|------|-------------------------|---------------|---------|
| | | Item | From | To |
| 2022-11-23 | A | Datasheets Release | / | / |
| 2023-03-07 | B | Mechanical Outline | / | Updated |
| 2023-07-31 | C | Features | / | Updated |
| | | Models | Notes(6) | Updated |
| | | Safety & EMC Compliance | / | Updated |
| | | Dimming | / | Updated |
| | | Mechanical Outline | EUM-200SxxxEE | Added |
| 2024-01-20 | D | Format | / | Updated |
| | | BIS logo | / | Added |
| | | Models | / | Updated |
| | | General Specifications | / | Updated |
| | | Safety & EMC Compliance | / | Updated |
| | | Inrush Current Waveform | / | Updated |
| | | Dimming | / | Updated |
| | | Mechanical Outline | / | Updated |