

Features

- Non-Isolated Class I driver
- Low Residual Output Voltage < 2kV
- No Afterglow
- Dim-to-Off with Standby Power $\leq 0.5W$ @ 230Vac
- Dimming Range: 0.4%-100%
- 3*600W Independent Programmable Channels & Support Common Anode Output Connection
- Max Remote Distance Up to 300 Meters
- Ultra High Efficiency (Up to 97%)
- Full Power at Wide Output Current Range (Constant Power)
- Adjustable Output Current (AOC) via DALI/DMX-RDM
- DALI-2 and D4i Certified & DMX-RDM & 3-Timer-Modes Dimmable
- Single-channel (1*DT6 or 1*DMX) Operating Mode
- DALI-2/DMX-RDM Controls Up to 33 fps
- Integrated Power Metering with High Accuracy up to $\pm 1\%$
- Thermal Sensing and Protection for LED Module
- Low Inrush Current
- Output Lumen Compensation
- End-of-Life Indicator
- Input Surge Protection: DM 10kV, CM 10kV
- All-Around Protection: IOVP, IUVP, OVP, SCP, OTP
- IP66
- IK08 Enclosure
- 5 Years Warranty



Description

The NES-1K8TxxxBC series is a non-isolated 1800W, 3 channels, constant-current, programmable and IP66 LED driver that operates from 198-457 Vac input with excellent power factor. Created for many lighting applications including sports, high mast, UV-LED, aquaculture and horticulture, etc. The dimming control supports two-way communication via DALI-2 and complies with D4i, furthermore it incorporates DMX-RDM dimming. The high efficiency of these drivers and compact metal case enables them to run cooler, significantly improving reliability and extending product life. To ensure trouble-free operation, protection is provided against input surge, input under voltage, input over voltage, output over voltage, short circuit, and over temperature.

Models

Adjustable Output Current Range (A)	Full-Power Current Range (A) ⁽¹⁾	Default Output Current (A)	Output Voltage Range (Vdc)	Max. Output Power (W)	Typical Efficiency ⁽²⁾	Typical Power Factor		Model Number <small>(3) (4) (5)</small>
						220Vac	400Vac	
0.0048-2.1	1.2-2.1	1.2	176-500	1800	97.0%	0.99	0.96	NES-1K8T210BC

- Notes:** (1) Output current range with constant power at 600W per channel.
 (2) Measured at 100% load and 400Vac input (see below "General Specifications" for details).
 (3) Certified voltage range: 220-415Vac
 (4) For KC and SAA certified models, please contact the sales for ordering if necessary.
 (5) For BIS models add suffix -3000.

I-V Operation Area

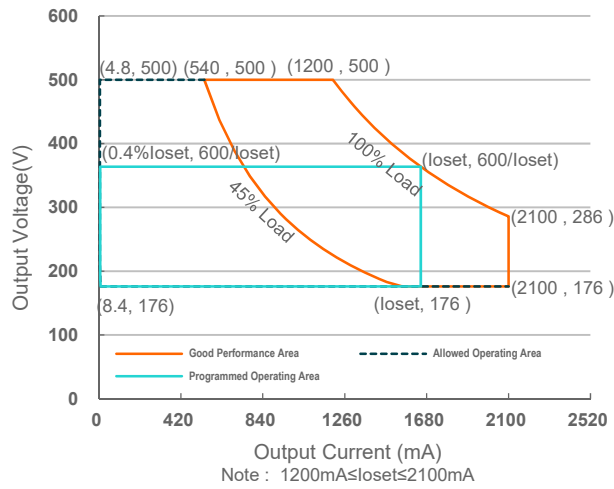

Driver Function Diagram

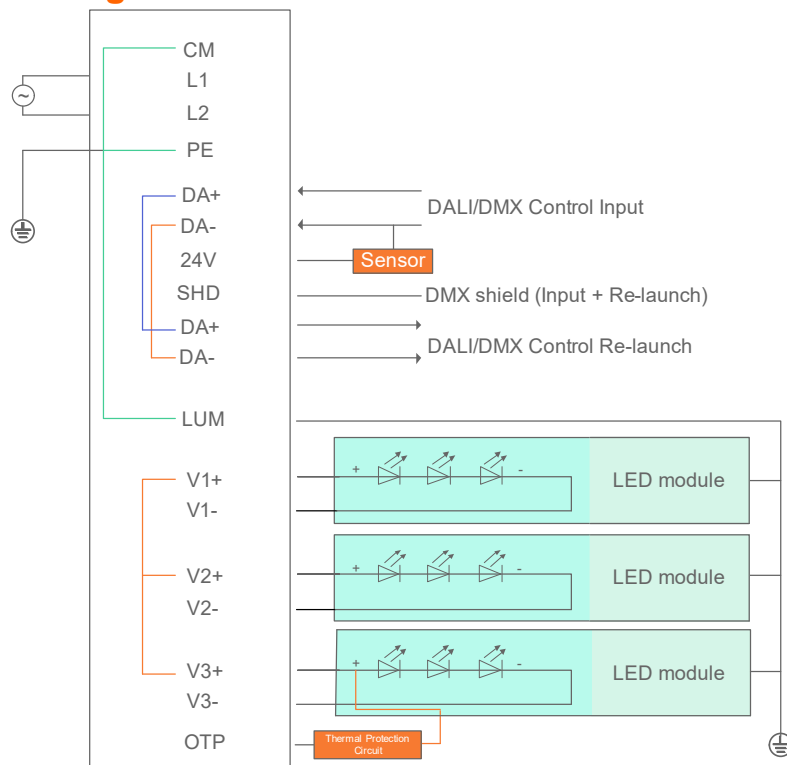

Input Specifications

Parameter	Min.	Typ.	Max.	Notes
Input AC Voltage	198 Vac	-	457 Vac	
Input DC Voltage	255 Vdc	-	500 Vdc	
Input Frequency	47 Hz	-	63 Hz	

Input Specifications (Continued)

Parameter	Min.	Typ.	Max.	Notes
Leakage Current	-	-	0.70 mA	IEC 60598-1; 415Vac/ 60Hz
Input AC Current	-	-	9.52 A	Measured at 100% load and 220 Vac input.
	-	-	5.18 A	Measured at 100% load and 400 Vac input.
Inrush Current(I ² t)	-	-	3.66 A ² s	At 415Vac input, 25°C cold start, duration=28 ms, 10%I _{pk} -10%I _{pk} .
PF	0.90	-	-	At 220-415Vac, 50-60Hz, 45%-100% Load (810 - 1800W)
THD	-	-	20%	
THD	-	-	10%	At 220-240Vac, 50-60Hz, 75%-100% Load (1350 - 1800W)

Output Specifications

Parameter	Min.	Typ.	Max.	Notes
Output Current Tolerance	-5%loset	-	5%loset	100% load
Output Current Setting(loset) Range				
NES-1K8TxxxBC	21 mA	-	2100 mA	
Output Current Setting Range with Constant Power				
NES-1K8TxxxBC	1200 mA	-	2100 mA	
Total Output Current Ripple (pk-pk)	-	2%I _{omax}	5%I _{omax}	100% load, 20 MHz BW
Output Current Ripple at < 3000 Hz (pk-pk)	-	1%I _{omax}	-	100% load
Startup Overshoot Current	-	-	10%I _{omax}	100% load
No Load Output Voltage	-	-	600 V	
Line Regulation	-	-	±0.5%	100% load
Load Regulation	-	-	±3.0%	
Turn-on Delay Time	-	-	1.0 s	Measured at 198-415Vac input, 50%-100% Load
Temperature Coefficient of loset	-	0.03%/°C	-	Case temperature = 0°C ~T _c max

Output Specifications (DALI Dimming Mode)

Parameter	Min.	Typ.	Max.	Notes
24V Auxiliary Output Voltage	21.6 V	24 V	26.4 V	P _{load} ≥ 0.1W
	-	-	30 V	P _{load} < 0.1W
24V Auxiliary Output Voltage ripple (pk-pk)	-	-	1.0 V	P _{load} ≥ 0.1W, f _{ripple} > 10kHz
24V Auxiliary Output Source Current	0 mA	-	125 mA	Return terminal is "DA-"

Output Specifications (DALI Dimming Mode) (Continued)

Parameter	Min.	Typ.	Max.	Notes
24V Auxiliary Output Transient Peak Current@6W	-	-	250 mA	250mA peak for a maximum duration of 2.2ms in a 6.0ms period during which time the average should not exceed 125mA.
24V Auxiliary Output Transient Peak Current@10W	-	-	425 mA	425mA peak for a maximum duration of 1.3ms in a 5.2ms period during which time the average should not exceed 125mA.
Integrated DALI-2 Bus Power Supply Voltage	12 Vdc	16 Vdc	20 Vdc	Voltage is depending on loading.
Integrated DALI-2 Bus Power Maximum Supply Current	60 mA			
Integrated DALI-2 Bus Power Guaranteed Supply Current	50 mA			DALI-2 Bus Power Supply Voltage \geq 12V

- Notes:** (1) DALI-2 bus power supply is enabled by default and can be disabled via programming interface.
 (2) DALI-2 bus power supply supports automatic shut-down and restart after short-circuit.
 (3) V1-, V2- and V3- cannot support common cathode output connection.

General Specifications

Parameter	Min.	Typ.	Max.	Notes
Efficiency at 220 Vac input: Io= 1200 mA Io= 2100 mA	93.5% 92.5%	95.5% 94.5%	- -	Measured at 100% load and steady-state temperature in 25°C ambient; (Efficiency will be about 2.0% lower if measured immediately after startup.)
Efficiency at 277 Vac input: Io= 1200 mA Io= 2100 mA	94.5% 93.5%	96.5% 95.5%	- -	Measured at 100% load and steady-state temperature in 25°C ambient; (Efficiency will be about 2.0% lower if measured immediately after startup.)
Efficiency at 400 Vac input: Io= 1200 mA Io= 2100 mA	95.0% 94.0%	97.0% 96.0%	- -	Measured at 100% load and steady-state temperature in 25°C ambient; (Efficiency will be about 2.0% lower if measured immediately after startup.)
Power Monitoring Accuracy	-1%	-	1%	Measured at 457Vac input and 100%Load
Standby Power	-	1.5 W	-	Measured at 415Vac/50Hz; Dimming off
	-	-	0.5 W	Measured at 230Vac/50Hz; Dimming off when Bus Power Supply is disabled
MTBF	-	207,000 Hours	-	Measured at 220Vac input, 80%Load and 25°C ambient temperature (MIL-HDBK-217F)
Lifetime	-	89,000 Hours	-	Measured at 220Vac input, 80%Load and 70°C case temperature; See lifetime vs. Tc curve for the details
Operating Case Temperature for Safety Tc_s	-40°C	-	+90°C	
Operating Case Temperature for Warranty Tc_w	-40°C	-	+80°C	Case temperature for 5 years warranty Humidity: 10%RH to 95%RH
Storage Temperature	-40°C	-	+85°C	Humidity: 5%RH to 95%RH
Dimensions Inches (L × W × H) Millimeters (L × W × H)	19.69 × 5.98 × 3.54 500 × 152 × 90			With Glands 20.67 × 5.98 × 3.54 525 × 152 × 90
Net Weight	-	7000 g	-	

Dimming Specifications

Parameter		Min.	Typ.	Max.	Notes
DALI Dimming Mode (Default)	DA+, DA- High Level	9.5 V	16 V	22.5 V	
	DA+, DA- Low Level	-6.5 V	0 V	6.5 V	
	DA+, DA- Current	0 mA	-	2 mA	
	Dimming Output Range	0.4% loset	-	loset	1200 mA ≤ loset ≤ 2100 mA
4.8 mA		-	loset	21 mA ≤ loset < 1200 mA	
DMX-RDM Dimming Mode	DMX+ to DMX-	-6 V	-	6 V	
	DMX+ to Chassis	22M ohm	-	-	
	DMX- to Chassis	22M ohm	-	-	
	Logic 0 Input	-	-	-0.2 V	DMX+ to DMX-
	Logic 1 Input	0.2 V	-	-	DMX+ to DMX-
	Communication Baud Rate	-	250k bps	-	
	Dimming Output Range	0.4% loset	-	loset	1200 mA ≤ loset ≤ 2100 mA
4.8 mA		-	loset	21 mA ≤ loset < 1200 mA	

Safety & EMC Compliance

Safety Category	Standard
ENEC & CE	EN 61347-1, EN61347-2-13
CB	IEC 61347-1, IEC 61347-2-13
CCC	GB 19510.1, GB 19510.14
KC	K 61347-1, K 61347-2-13
SAA	AS/NZS 61347.1, AS/NZS 61347.2.13
BIS	IS 15885(Part2/Sec13)
Performance	Standard
ENEC	EN IEC 62384
EMI Standards	Notes
EN IEC 55015/GB/T 17743/ KS C 9815 ⁽¹⁾	Conducted emission Test & Radiated emission Test
EN IEC 61000-3-2/GB 17625.1	Harmonic current emissions
EN 61000-3-3	Voltage fluctuations & flicker

Safety & EMC Compliance (Continued)

EMS Standards	Notes	
EN 61000-4-2	Electrostatic Discharge (ESD): 8 kV air discharge, 4 kV contact discharge	
EN 61000-4-3	Radio-Frequency Electromagnetic Field Susceptibility Test-RS	
EN 61000-4-4	Electrical Fast Transient / Burst-EFT	
EN 61000-4-5	AC mains	Surge Immunity Test: AC Power Line: Differential Mode 10 kV, Common Mode 10 kV ⁽²⁾
	Output	- Common Mode: 3kV V1+/V2+/V3+ to PE V1-/V2-/V3- to PE - Differential Mode: 1kV (V1+ to V1-, V2+ to V2-, V3+ to V3-)
EN 61000-4-6	Conducted Radio Frequency Disturbances Test-CS	
EN 61000-4-8	Power Frequency Magnetic Field Test	
EN 61000-4-11	Voltage Dips	
EN 61547/KS C 9547	Electromagnetic Immunity Requirements Applies To Lighting Equipment	
DALI-2 Standards	Notes	
DALI-2 ⁽³⁾	IEC 62386-101, -102 & -207	

Note: (1) This LED driver meets the EMI specifications above, but EMI performance of a luminaire that contains it depends also on the other devices connected to the driver and on the fixture itself.

(2) To perform electric strength (hi-pot) testing, the wire plugged in CM terminal should be removed temporarily to prevent the internal gas discharge tube from conducting (as allowed by IEC 60598-1 Clause10.2). After testing is completed, this wire must be reconnected to restore line-to-earth surge protection.

(3) DALI parts: 101, 102, 150, 207, 250, 251, 252, 253.

● Isolation Levels between Different Circuits:

	AC Input	DC Output	Dimming (SELV)	Housing
AC Input	/	No isolation	Double	Basic
DC Output	No isolation	/	Double	Basic
Dimming (SELV)	Double	Double	/	Basic
Housing	Basic	Basic	Basic	/

Lifetime vs. Case Temperature

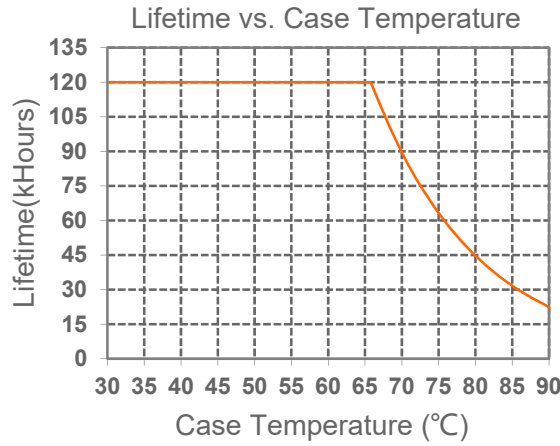

Inrush Current Waveform

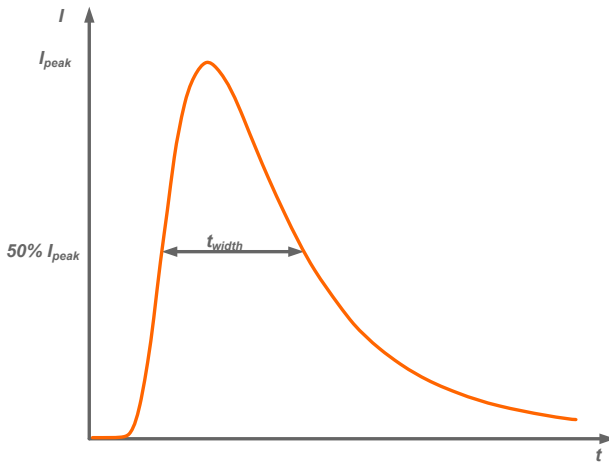

Input AC Voltage	I_{peak}	t_{width} (@ 50% I_{peak})
415 Vac	13.2 A	7.40 ms

Efficiency vs. Load

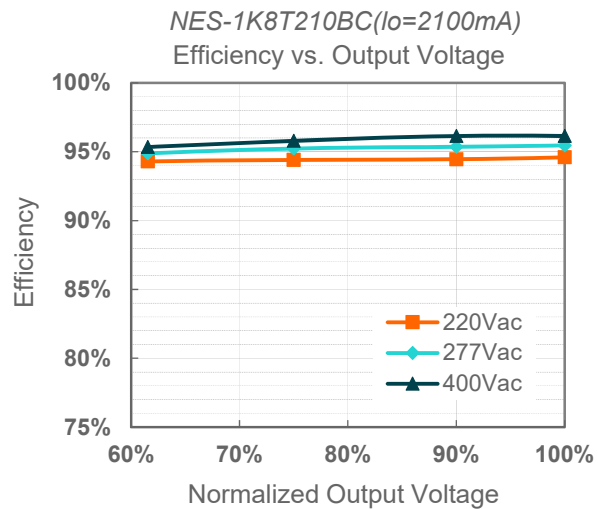
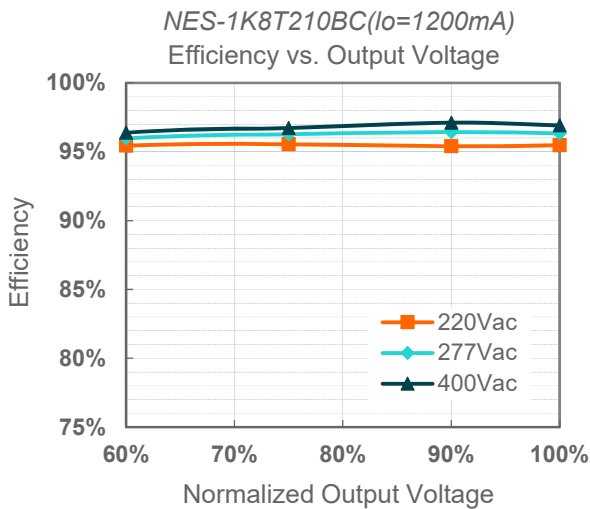

Power Factor

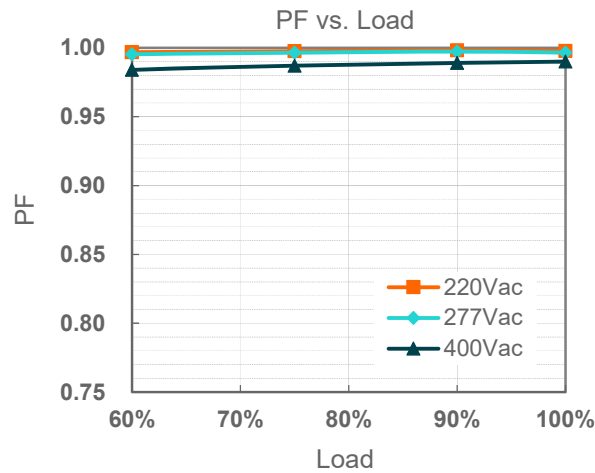

Total Harmonic Distortion

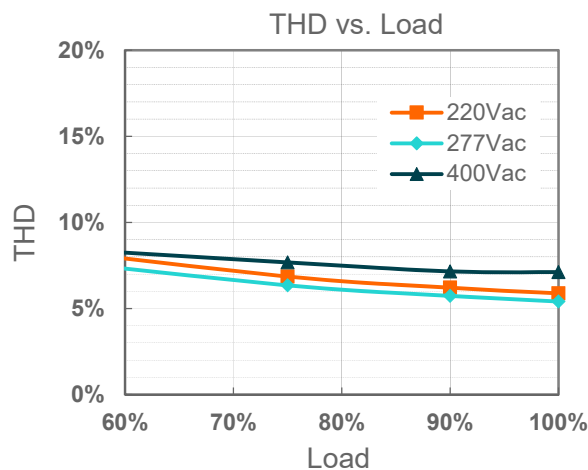

Protection Functions

Parameter		Min.	Typ.	Max.	Notes
Over Temperature Protection		Decreases output current smoothly, returning to normal after over temperature is removed.			
Short Circuit Protection		Auto Recovery. No damage will occur when any output is short circuited. The output shall return to normal when the fault condition is removed.			
Over Voltage Protection		Limits output voltage at no load and in case the normal voltage limit fails.			
Input Under Voltage Protection (IUVP)	Input Protection Voltage	170 Vac	180 Vac	190 Vac	Turn off the output when the input voltage falls below protection voltage.
	Input Recovery Voltage	180 Vac	190 Vac	200 Vac	Auto Recovery. The driver will restart when the input voltage exceeds recovery voltage.
Input Over Voltage Protection (IOVP)	Input Protection Voltage	460 Vac	470 Vac	480 Vac	Turn off the output when the input voltage exceeds protection voltage.
	Input Recovery Voltage	440 Vac	450 Vac	460 Vac	Auto Recovery. The driver will restart when the input voltage falls below recovery voltage.
	Max. of Input Over Voltage	-	-	480 Vac	The driver can survive for 8 hours with a stable input voltage stress of 480Vac

● Input Under Voltage Protection Diagram

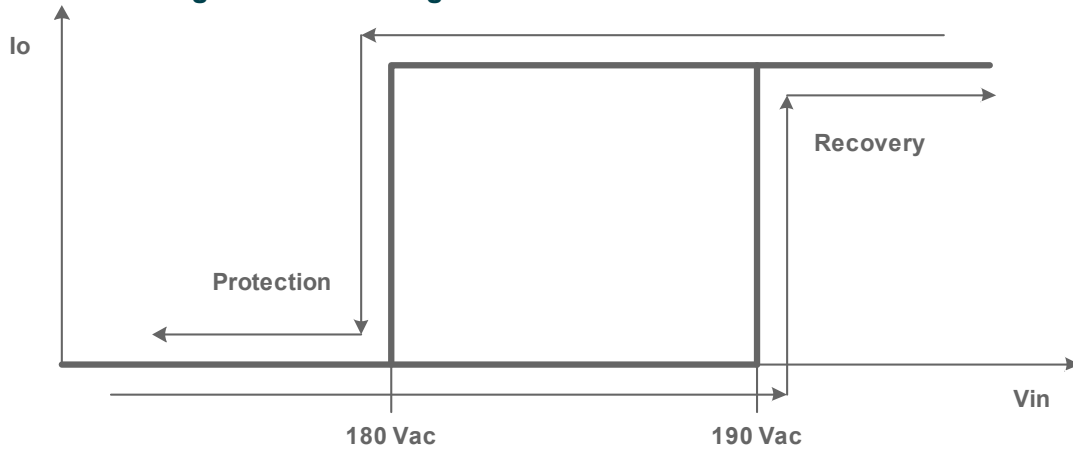

● Input Over Voltage Protection Diagram

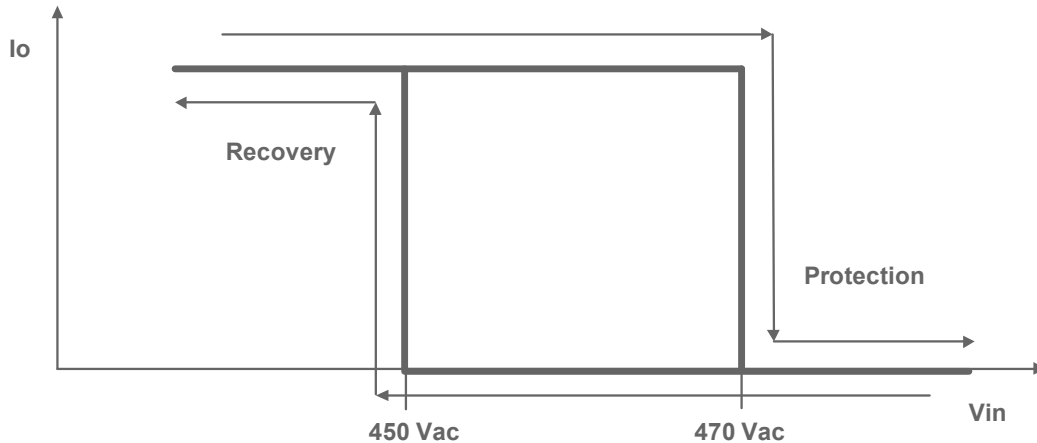

● External Thermal Protection

This needs an external circuit which locates on the hottest part of LEDs to protect the whole lumianires when the temperature exceeds the ratings. The circuit will be connected by V+ LED and OTP terminal on driver. The default protection temperature point is 90°C, it can be changed by Inventronics programmer along with the actual target.

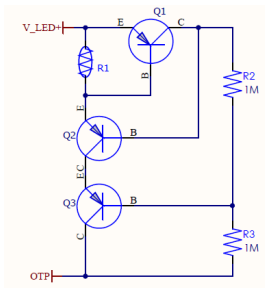

Reference	Description	Recommendation
Q1/Q2/Q3	500V PNP high-voltage transistor	NEXPERIA / PBHV9050T
R1	NTC 10KΩ	0603 SMD 3% EPCOS / TDK B57371V2103H060 B25-100=4480
R2/R3	1MΩ Resistor	1M 1% -55~155°C 0805/1206 500V

● Strobe function

NES-1K8 driver supports strobe function up to 33 fps from 100% dimming to 0% change forth and back. In order to protect relays reliability, the relays will still keep 3s 'ON' status when receiving the dim-to-off command and then enter "OFF" status without receiving dimming ON command. but it will immediately operates back to "ON" status if receiving the dimming on command, so the relays will not operate 'ON' and 'OFF' frequently in fast strobe operation within 3s duration time in default mode. When the duration time of strobe operation is between 3s and 15 minutes, the commands below need to be added for ensuring the relay lifetime.

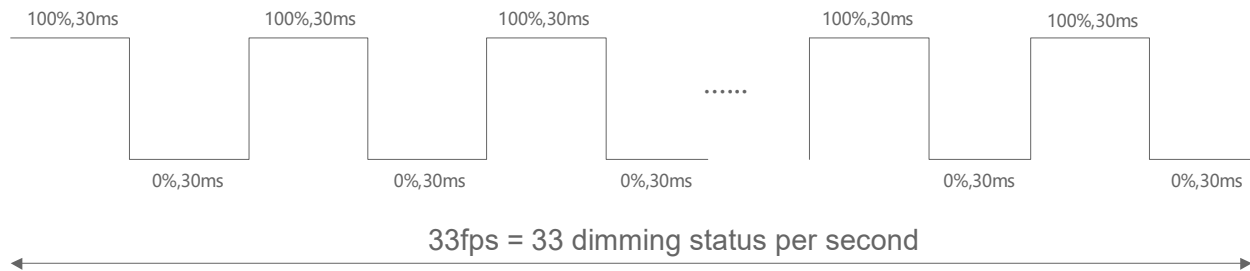

(1) DALI-2 Dimming Mode

Type	Commands	Hex Data	Send Twice	Notes
Special	DTR1 = 2 (0x02)	C3 02	-	Set the relay to 'always-ON' when dim-to-off, the status reverts to default upon restart.
Special	DTR2 = 1 (0x01)	C5 01	-	
Special	ENABLE DEVICE TYPE 100	C1 64	-	
Configuration	Cmd217 RESERVED	FF D9	✓	
Special	DTR1 = 2 (0x02)	C3 02	-	Return to default mode
Special	DTR2 = 0 (0x00)	C5 00	-	
Special	ENABLE DEVICE TYPE 100	C1 64	-	
Configuration	Cmd217 RESERVED	FF D9	✓	

(2) DMX Dimming Mode

Inventronics PIDs Defines		
RDM Parameter ID's (Slot 21-22)	Value	Notes
ENTER_PROTECTED_STROBE_MODE	0x8002	Set the relay to 'always-ON' when dim-to-off, the status reverts to default upon restart.
EXIT_PROTECTED_STROBE_MODE	0x8003	Return to default mode

Dimming (DALI Dimming Mode)

● DALI-2 Dimming

The recommended implementation of the dimming control is provided below.

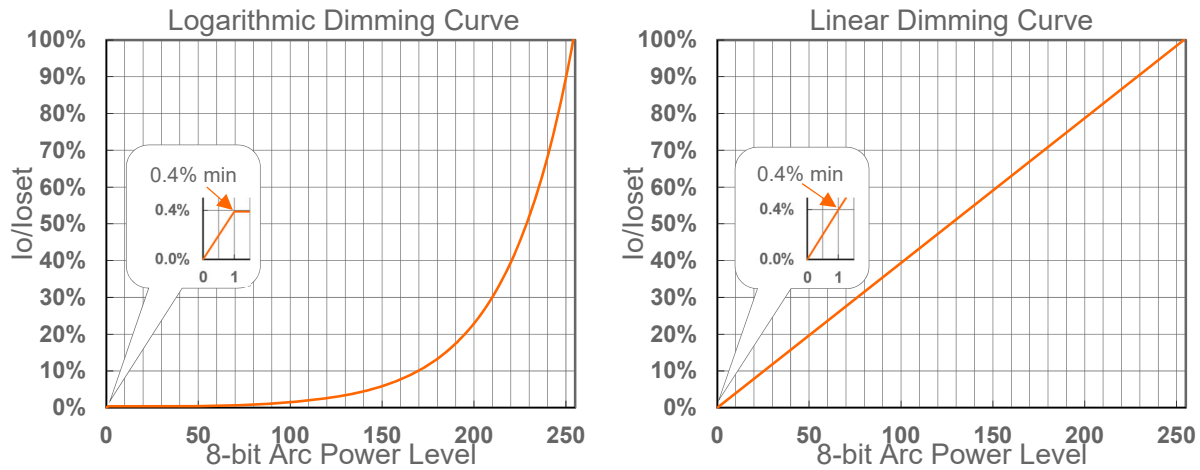

Implementation: DALI-2 Dimming

Dimming (DMX-RDM Dimming Mode)

● DMX-RDM Dimming

The recommended implementation of the dimming control is provided below.

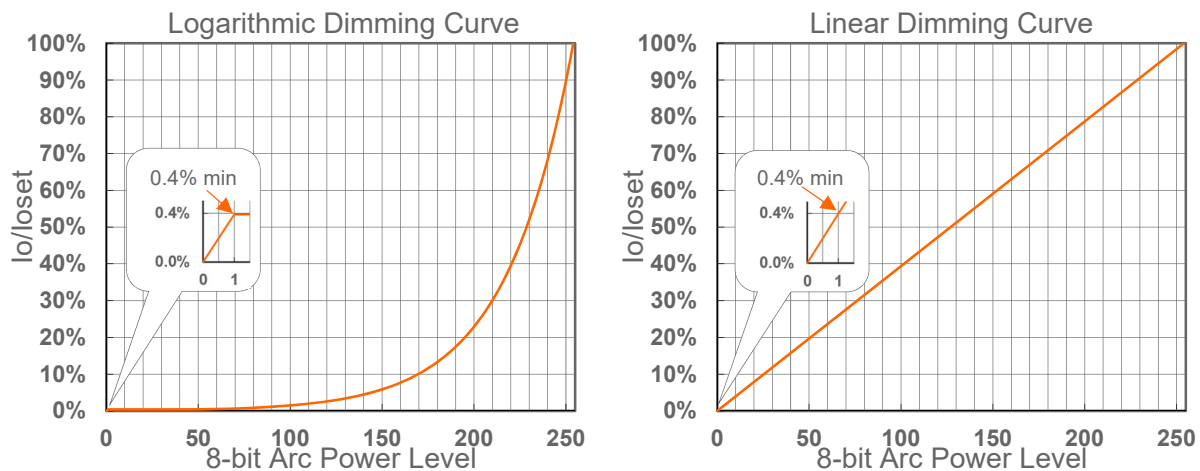

Implementation: DMX-RDM Dimming

- Note:**
- (1) Up to 32 drivers may be daisy-chained, terminated by a 120 ohms resistor (connected between DMX+ & DMX- at the last driver)
 - (2) 300m maximum length
 - (3) 100m maximum between drivers
 - (4) For best performance, a characteristic impedance of 120 ohms should be maintained for the entire length of the control line.

● Time Dimming

Time dimming control includes 3 kinds of modes, they are Self Adapting-Midnight, Self Adapting-Percentage and Traditional Timer.

- **Self Adapting-Midnight:** Automatically adjusts the dimming curve based on the on-time of past two days (if difference <15 minutes), assuming that the center point of the dimming curve is midnight local time.
- **Self Adapting-Percentage:** Automatically adjusts the on-time of each step by a constant percentage = (actual on-time for the past 2 days if difference <15 min) / (programmed on-time from the dimming curve).
- **Traditional Timer:** Follows the programmed timing curve after power on with no changes.

● Output Lumen Compensation

Output Lumen Compensation (OLC) may be used to maintain constant light output over the life of the LEDs by driving them at a reduced current when new, then gradually increasing the drive current over time to counteract LED lumen degradation.

● End Of Life

End-of-Life (EOL) is providing a visual notification to a user that the LED module has reached the end of manufacturer-specified life and that the replacement is recommended. Once active, an indication is given at each power-up of the driver, which the driver indicates this through a lower light output during the first 1 minute before normal operation is continued.

● Cable Gland Diagram

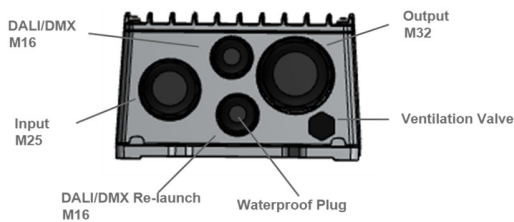

Connection	Cable Gland	Toque (N·m)	Cable Diameter (mm)	Cable AWG	Cable Section (mm ²)
AC Input	M25	5.5	13-18	15-12	1.5-2.5
DC Output	M32	7.5	15-21	15-12	1.5-2.5
DALI/DMX	M16	2.5	5-10	18-12	0.75-2.5
DALI/DMX Re-launch	M16	2.5	5-10	18-12	0.75-2.5

● Connection Diagram

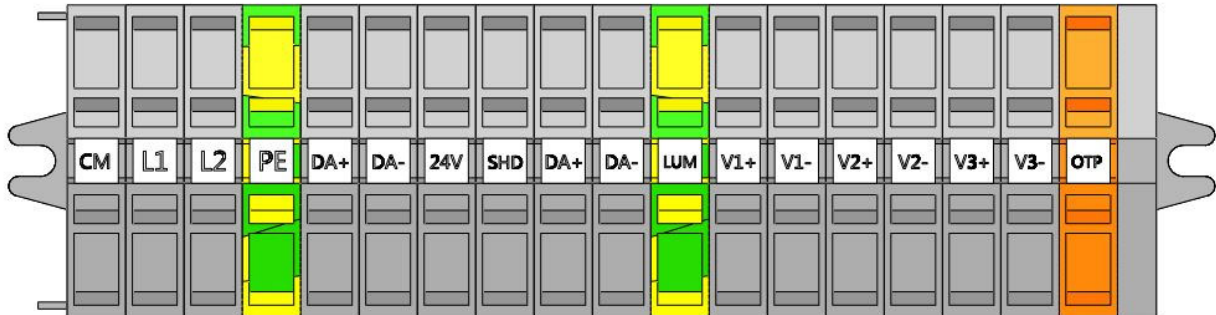

Number	Label	Description
1	CM	Surge protection connection
2	L1	AC input L1/L
3	L2	AC input L2/N
4	PE	Protection Earth
5	DA+	Reused,DALI/DMX input+
6	DA-	Reused,DALI/DMX input-
7	24V	24V auxiliary source
8	SHD	DMX SHIELD
9	DA+	DALI/DMX reused Re-launch output+
10	DA-	DALI/DMX reused Re-launch output-
11	LUM	Protection Earth for LED Module
12	V1+	LED1+ Connection
13	V1-	LED1- Connection
14	V2+	LED2+ Connection
15	V2-	LED2- Connection
16	V3+	LED3+ Connection
17	V3-	LED3- Connection
18	OTP	Thermal protection input

Note: DALI function and DMX function cannot be used at the same time.

● Cable Connection Diagram

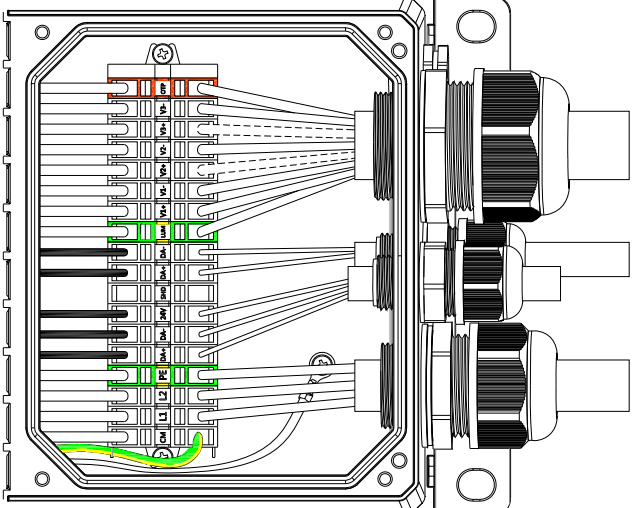
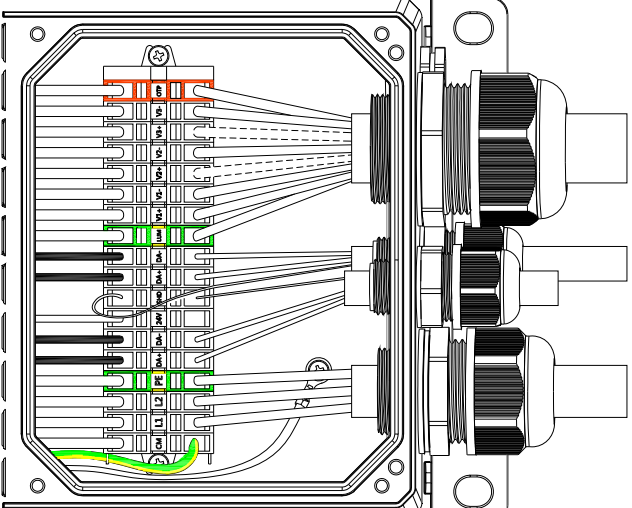
Parameter	Cable Connection	Notes
<p>A typical configuration when using DALI</p>		<ol style="list-style-type: none"> 1. The DALI circuit provides a 24 Vdc auxiliary source; there is no auxiliary source for the DMX-RDM circuitry. 2. When hi-pot testing, you need to remove the yellow/green colored 'CM wire' as shown in the drawings; and then reconnect after the test.
<p>A typical configuration when using DMX-RDM</p>		

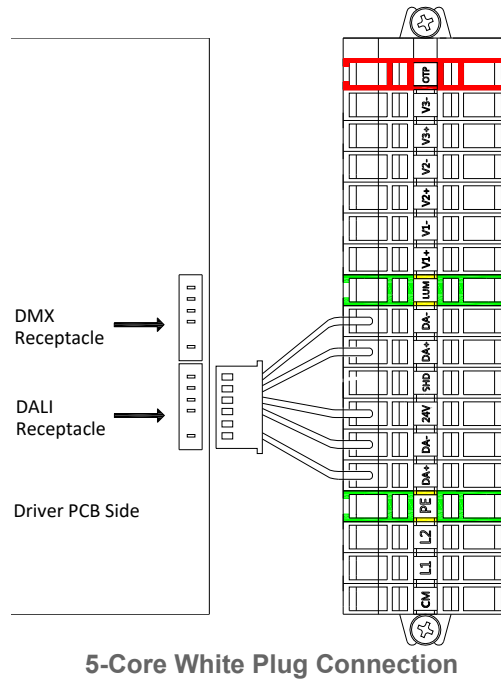

There is a 5 core plug that is connected to DA+,DA-,24V,DA+,DA- terminals, and there are two receptacles on the driver's PCB marked 'DALI' and 'DMX', Please adjust the plug location to corresponding dimming mode. The default dimming mode is DALI.

Programming Connection Diagram

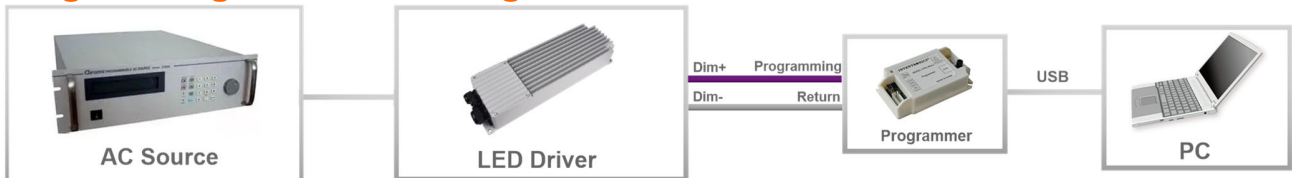

Note: The driver needs to be powered on during the programming process.

- Please refer to [PRG-MUL2](#) (Programmer) datasheet for details.

How to Program to Switch between DALI (default) and DMX-RDM

● Switch DALI to DMX-RDM

Step 1: Ensure the plug is connected to DALI Receptacle

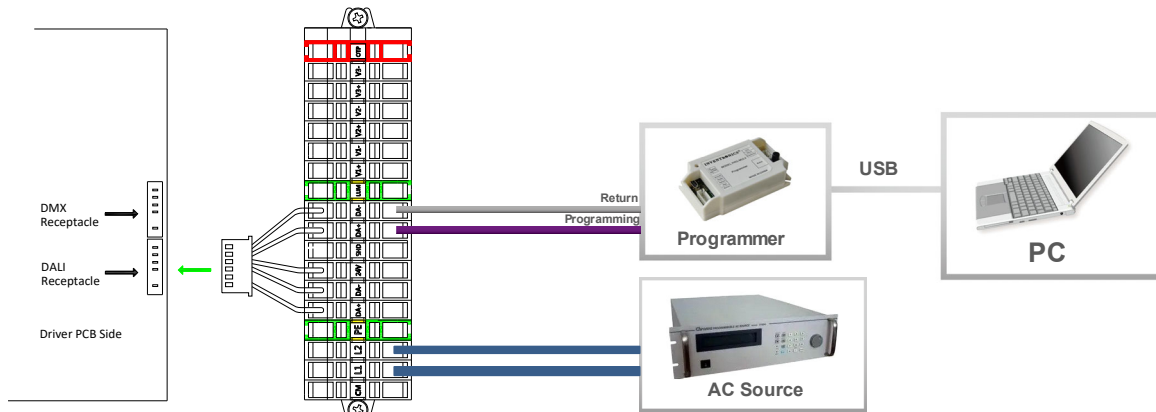

Step 2: Select “DMX” dimming mode and click ‘Write’ in INV PC Programming Interface

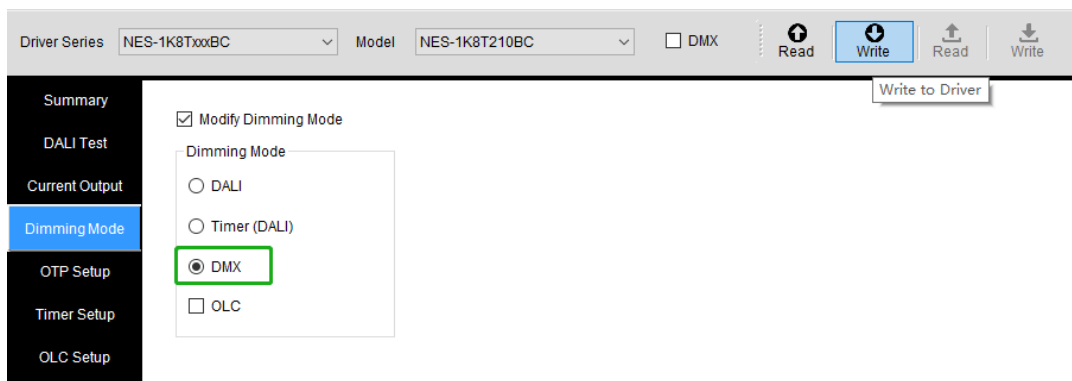

Step 3: Change the plug position to DMX Receptacle

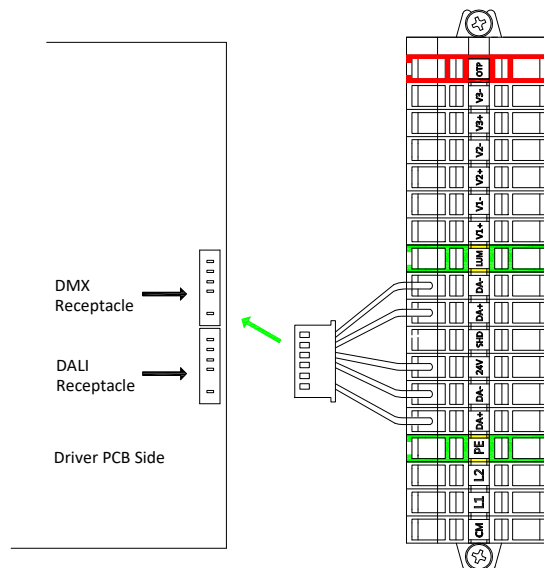

● **Switch DMX-RDM to DALI**

Step 1: Ensure the plug is connected to DALI Receptacle

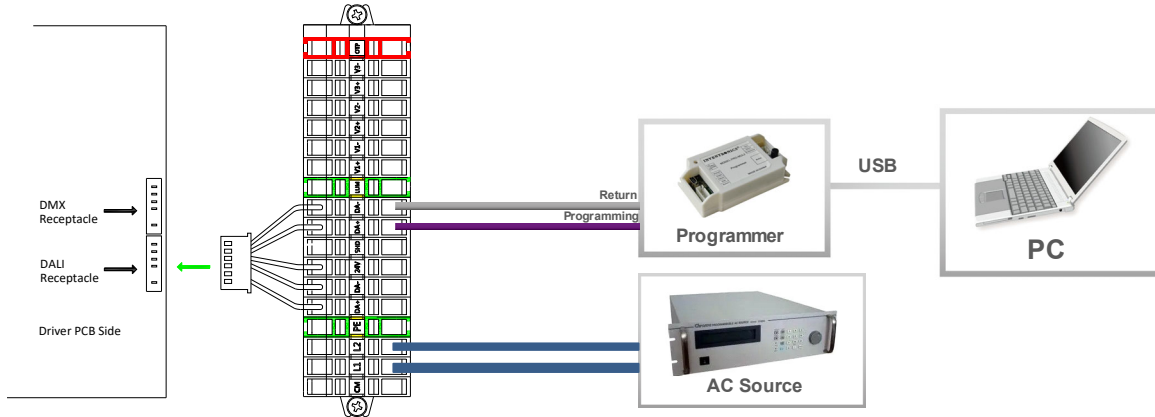

Step 2: Select “DALI” dimming mode and click ‘Write’ in INV PC Programming Interface

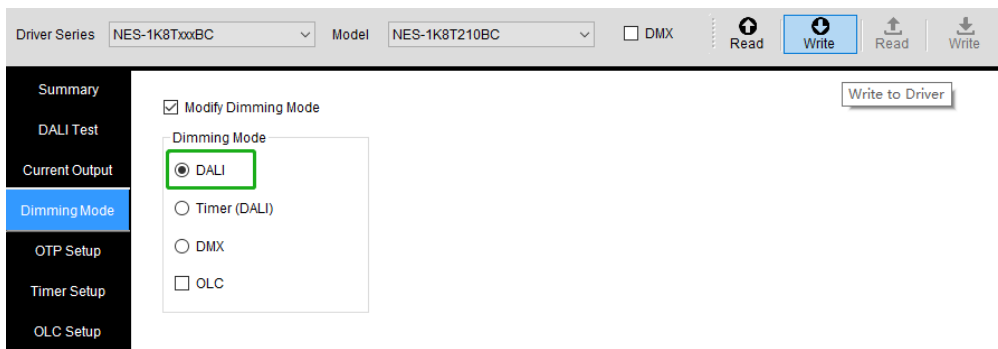

Step 3: Ensure the plug remains to DALI Receptacle

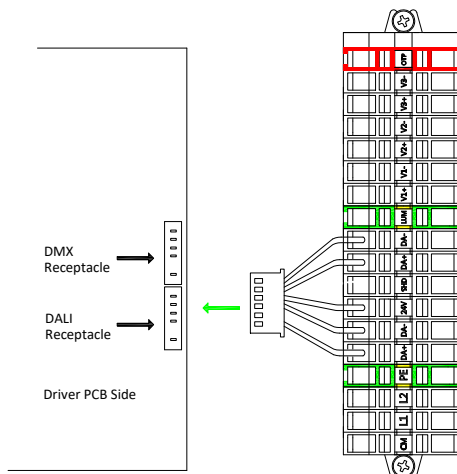

Mechanical Outline

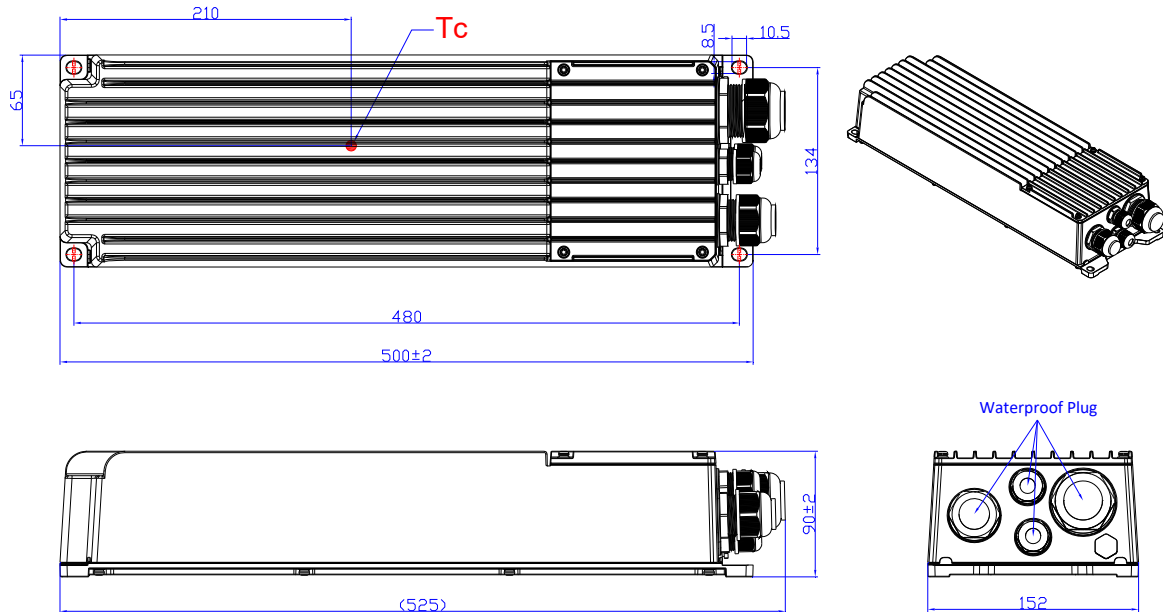

PROJ:

Unspecified tolerance: ±1

RoHS Compliance

Our products comply with reference to RoHS Directive (EU) 2015/863 amending 2011/65/EU, calling for the elimination of lead and other hazardous substances from electronic products.

Revision History

Change Date	Rev.	Description of Change		
		Item	From	To
2023-05-19	A	Datasheet Release	/	/
2023-08-10	B	Models	Note (4)	Added
2024-03-20	C	Format	/	Updated
		Header	/	Updated
		UKCA logo	/	Deleted
		BIS logo	/	Added
		Features	/	Updated
		Description	/	Updated
		Models	Note (5)	Added
		Input Specifications	/	Updated
		General Specifications	/	Updated
		Dimming Specifications	/	Updated
Safety & EMC Compliance	/	Updated		